

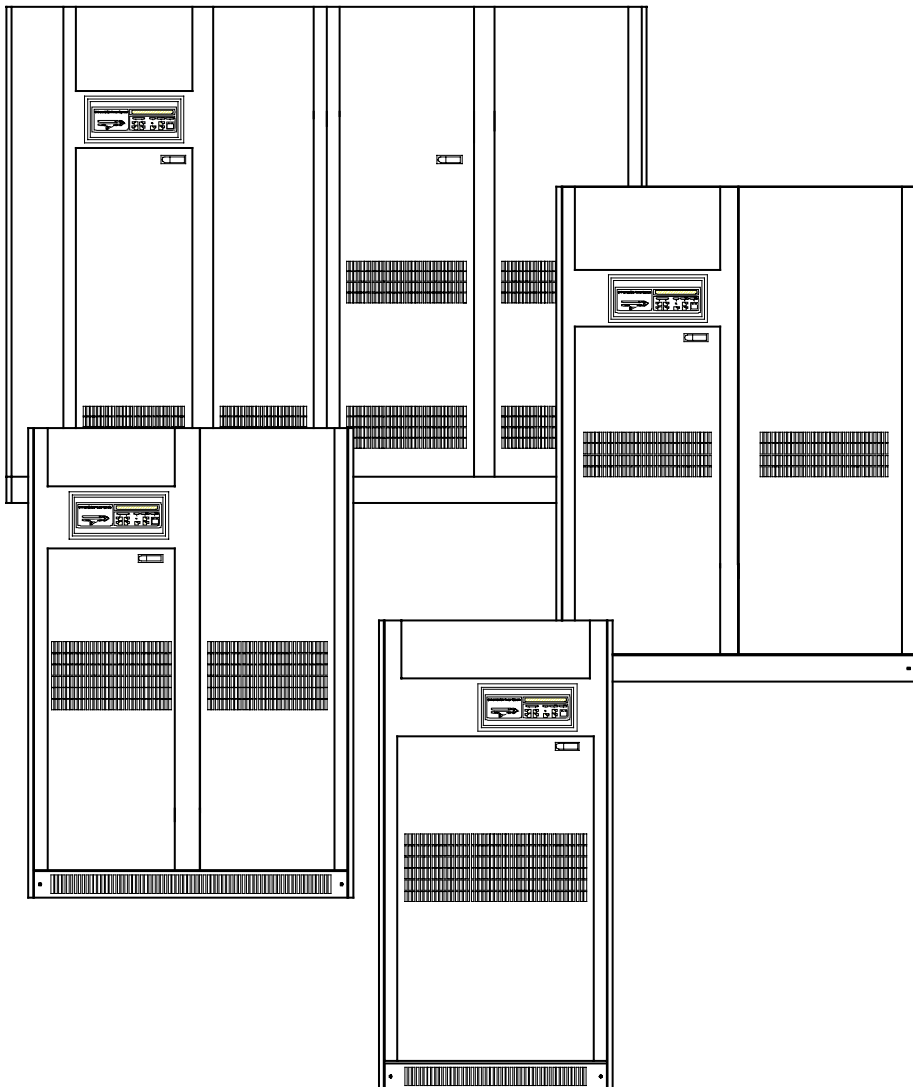

# 7400 Series UPS Single Module and 1+1 Configuration



## User Manual



## IMPORTANT

*This manual contains information concerning the installation, operation and maintenance of the Liebert Series 7400 Uninterruptible Power System (UPS) for the Single Module and One plus One Systems.*

*All relevant parts of the manual should be read prior to commencing installation.*

**The UPS must be commissioned by an engineer approved by the manufacturer (or his agent) before being put into to service. Failure to observe this condition will invalidate any implied warranty.**

*The Series 7400 UPS has been designed for Commercial/Industrial use only.*

*The Series 7400 UPS has not been designed for direct use in any life support applications.*

*If you encounter any problems with the procedures contained in this manual you should seek immediate assistance from the Liebert Sales Office from whom the equipment was purchased. Alternatively contact the manufacturer's Customer Support department at the address shown below:*

*Customer Service and Support Department,  
Customer Support Systems,  
Liebert Europe  
Globe Park, Marlow, SL7 1YG, U.K.*

*Telephone (01628) 403200  
Fax (01628) 403302  
Outside the UK prefix the number with - (44 - 1628)*

*The manufacturer reserves the right to change the equipment design without notice.*

*©Copyright 1998 by Liebert Europe.  
Unauthorised reproduction prohibited*

*All rights reserved.*

### ***ELECTRO MAGNETIC COMPATIBILITY***

#### **WARNING**

This is a UPS for restricted sales distribution to informed partners with the appropriate EMC technical competence. Installation restrictions or additional measures may be needed to prevent disturbances (EMC Standard 50091-2).

To convert to a class `A' UPS, the following factory installed optional e.m.c. kits must be fitted:

80 kVA Module - Option kit part number 4641018 S

120 kVA Module - Option kit part number 4641014 O

200 kVA Module - Option kit part number 4641029 D

300 kVA Module - Option kit part number -

400 kVA Module - Option kit part number -

When fitted with the above optional e.m.c. kits the following warning applies:

This is a class `A' UPS product. In a domestic environment this product may cause radio interference in which case the user may be required to take additional measures.

This equipment complies with the requirements of the EMC Directive 89/336/EEC and the published technical standards.

Continued compliance requires installation in accordance with these instructions and the use of manufacturer approved accessories only.

**This manual describes the following equipment:**

<b>EQUIPMENT</b>	<b>PART NUMBER</b>
80 kVA UPS Module	5410270 I
120 kVA UPS Module	5410272 K
200 kVA UPS Module	5410276 O
300 kVA UPS Module	5410250 O
400 kVA UPS Module	5410252 Q
300 kVA UPS 12 pulse Module	5410251 P
400 kVA UPS 12 pulse Module	5410253 R
80 kVA 12 Pulse option	5332001 Z
120 kVA 12 Pulse option	5332002 A
200 kVA 12 Pulse option	5332004 C
80 kVA EMC compatibility kit	4641018 S
120 kVA EMC compatibility kit	4641014 O
200 kVA EMC compatibility kit	4641029 D
300 kVA EMC compatibility kit	
400 kVA EMC compatibility kit	
860 mm Battery Cabinet (250 Amp)	5320024 I
Battery Circuit Breaker Box for UPS 80 kVA (250 A)	4641007 H
Battery Circuit Breaker Box for UPS 120 kVA (400 A)	4641008 I
Battery Circuit Breaker Box for UPS 200 kVA (630 A)	4641009 J
Battery Circuit Breaker Box for UPS 300 kVA (800 A)	4641011 L
Battery Circuit Breaker Box for UPS 400 kVA (1000 A)	4641012 M
5th Harmonic Input filter 80 kVA	5331016 C
5th Harmonic Input filter 120 kVA	5331018 E
5th Harmonic Input filter 200 kVA	5331020 G
5th Harmonic Input filter 300 kVA (internal to UPS)	4641010 K
5th Harmonic Input filter 400 kVA (internal to UPS)	4641013 N
AS400 alarm interface board	4590041 B
AS400 ( X4 ) alarm interface board	4590045 F
External interface board	4590044 E
Remote Alarm Monitor (RAM)	4305001 Z
Remote alarm and control Panel	4305002 A
RS-232 Communications Interface (SGC)	4550002 C
Top cable entry kit for 80 kVA - 120 kVA	2174011 V
Top cable entry kit for 200 kVA	2174033 R

## Safety Precautions

### **WARNING**

THIS UPS DOES NOT INCORPORATE AUTOMATIC BACKFEED PROTECTION. A WARNING LABEL MUST BE FITTED TO ALL EXTERNAL PRIMARY POWER ISOLATORS STATING:  
ISOLATE THE UNINTERRUPTIBLE POWER SYSTEM BEFORE WORKING ON THIS CIRCUIT.

### **General**

In common with other types of high power equipment, dangerous voltages are present within the UPS and battery enclosure. The risk of contact with these voltages is minimised as the live component parts are housed behind a hinged, lockable door. Further internal safety screens make the equipment protected to IP20 standards. No risk exists to any personnel when operating the equipment in the normal manner, following the recommended operating procedures.  
All equipment maintenance and servicing procedures involve internal access and should be carried out only by trained personnel.

### **Batteries**

Battery manufacturers supply details of the necessary precautions to be observed when working on, or in the vicinity of, a large bank of battery cells. These precautions should be followed implicitly at all times.  
Particular attention should be paid to the recommendations concerning local environmental conditions and the provision of protective clothing, first aid and fire-fighting facilities.

### **Test Equipment**

When the battery is under charge it is earth-referenced about its mid-point e.g. if the battery is being charged at 446 V the battery extremities will be at +223V and -223V with respect to neutral (earth). When using mains-powered test equipment such as oscilloscopes in the UPS high voltage area, always use a *differential* mode of operation to avoid the need to disconnect the oscilloscope frame earth.

### **Personnel**

When working inside the UPS (trained personnel only) it is recommended that protection be worn to prevent eye damage, should an electrical arc be struck by mishandling or severe electrical fault.  
Some of the power components are very heavy. If their removal is necessary ensure that sufficient manpower is available, otherwise use adequate mechanical handling equipment. When working in the general area of the UPS where high voltages are present, a second person should be standing-by to assist and summon help in case of accident.

## Table of Contents

1. Chapter 1 - General Description .....	1-1
1.1 Introduction .....	1-1
1.2 Design Concept .....	1-1
1.2.1 Module Design .....	1-1
1.2.2 Bypass supplies .....	1-5
1.2.3 UPS Power Switch Configuration .....	1-5
1.2.4 Battery circuit breaker .....	1-6
1.2.5 Battery Cabinet .....	1-6
1.2.6 Battery circuit breaker box .....	1-6
1.3 One Plus One System .....	1-8
1.3.1 Redundant vs Non-Redundant configuration .....	1-8
1.3.2 One-Plus-One Parallel Control .....	1-8
1.3.3 Common battery .....	1-10
1.4 Operator Control Panel .....	1-12
1.4.1 Mimic indications .....	1-12
1.4.2 Control switches .....	1-13
1.4.3 LCD Display .....	1-15
2. Chapter 2 - Operating Instructions .....	2-1
2.1 Introduction .....	2-1
2.1.1 General notes .....	2-1
2.2 One plus One .....	2-1
2.2.1 Redundant module system .....	2-1
2.2.2 Non-Redundant module system .....	2-3
3. Chapter 3 - Installation Procedure .....	3-1
3.1 Introduction .....	3-1
3.1.1 Equipment positioning and environmental considerations .....	3-2
3.1.2 Raised floor installation .....	3-3
3.1.3 Battery Location .....	3-3
3.2 Preliminary Checks .....	3-13
3.3 Reassembling the 300 kVA and 400 kVA cabinets .....	3-14
3.4 Connecting the UPS power cables .....	3-16
3.4.1 Cable entry .....	3-16
3.4.2 Cable rating .....	3-16
3.4.3 Cable connections .....	3-17
3.4.4 Safety earth .....	3-17
3.4.5 Cabling procedure .....	3-18
3.5 Battery Installation .....	3-24
3.5.1 860 mm cabinet (250 Amp circuit breaker) .....	3-25
3.5.2 Battery circuit breaker boxes .....	3-28
3.5.3 Battery Display Initialisation .....	3-31
4. Chapter 4 - Optional equipment .....	4-1
4.1 AS400 Interface Board (4590041B) .....	4-2
4.1.1 AS400 Interface Board outputs .....	4-2
4.1.2 Remote control inputs .....	4-2
4.1.3 Calibration .....	4-2
4.2 4-Way AS400 Interface Board (4590045F) .....	4-4
4.2.1 Remote control inputs .....	4-4
4.2.2 Calibration .....	4-4
4.3 Output Interface (Remote Alarms) Boards (4590044E) .....	4-6
4.3.1 Alarm outputs .....	4-6
4.3.2 Remote control inputs .....	4-6
4.4 Remote Alarm Monitor (RAM) (P/N 4305001Z) .....	4-8

4.4.1 Connections .....	4-8
4.5 Remote Alarm and Control Panel (Part No. 4305002 A) .....	4-10
4.5.1 Introduction .....	4-10
4.5.2 Connections .....	4-11
4.6 RS 232 Communications Management Board (SGC) (4550002C) .....	4-15
4.6.1 Introduction .....	4-15
4.6.2 General Information .....	4-16
4.7 5th Harmonic Input Filter .....	4-18
4.7.1 Introduction .....	4-18
4.7.2 Specification .....	4-18
4.7.3 Notes on connection .....	4-18
4.8 Cable top entry kit .....	4-24
4.8.1 Introduction .....	4-24
4.9 Pulse Option .....	4-25
4.9.1 Introduction .....	4-25
4.9.2 Electrical connection .....	4-25
4.10 Option Board Kit (Part no. 77000005) .....	4-29
4.10.1 Introduction .....	4-29
4.10.2 Installation .....	4-29
5. Chapter 5 - Maintenance .....	5-1
5.1 Introduction .....	5-1
5.2 Safety Precautions .....	5-1
5.3 Scheduled Maintenance .....	5-1
5.3.1 Daily checks .....	5-1
5.3.2 Weekly checks .....	5-3
5.3.3 Annual Service .....	5-3
5.3.4 Extended service .....	5-4
5.3.5 Battery maintenance .....	5-4
6. Chapter 6 - Troubleshooting .....	6-1
6.1 Troubleshooting UPS Systems .....	6-1
6.1.1 Operating parameters and limitations .....	6-1
6.1.2 General Troubleshooting Procedure .....	6-1
6.2 Display panel message interpretation .....	6-5
7. Chapter 7 - SPECIFICATION .....	7-1



---

## 1. Chapter 1 - General Description

---

### 1.1 Introduction

---

The *7400 Series* uninterruptible power supply (UPS) system is connected between a critical load, such as a computer, and its three phase mains power supply. Being designed to furnish a well regulated 3 phase output power supply under all rated load and input supply conditions, the system offers the user the following advantages:-

*Increased power quality:*

The UPS has its own internal voltage and frequency regulator circuits which ensure that its output is maintained within close tolerances independent of voltage and frequency variations on the mains power lines.

*Increased noise rejection:*

By rectifying the input a.c. power to d.c. power, and then converting it back to a.c., any electrical noise present on the input mains supply line is effectively isolated from the UPS output, therefore the critical load sees only clean power.

*Power blackout protection:*

If the mains power fails, the UPS continues to power the critical load from its battery source, leaving the load immune from power disturbances.

### 1.2 Design Concept

---

#### 1.2.1 Module Design

This section describes an individual module's operating principles for both 6 and 12 pulse systems - the effects of the additional parallel control facilities required on the one plus one system on the standard module are described later.

***6 pulse Rectifier***

The UPS basically operates as an AC-DC-AC converter (see figure 1-1). The first conversion stage (from a.c. to d.c.) uses a 3 phase, fully-controlled SCR bridge rectifier to convert the incoming mains supply into a regulated 446 V d.c. busbar for a 400 V a.c. input (or 432 V d.c. for a 380 V a.c. input or 459 Vd.c. for a 415V a.c. input).

Figure 1-1. Series 7400 UPS Single Module block diagram

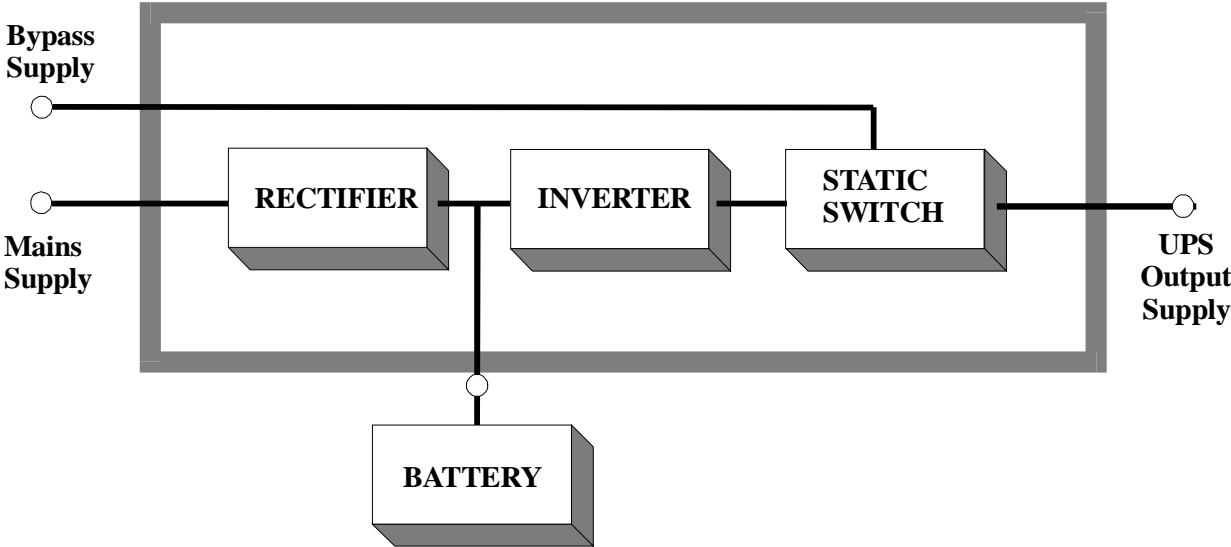

**12 Pulse Rectifier**

The UPS basically operates as an a.c.-d.c.-a.c. converter (see figure 1-1). The first conversion stage (from a.c. to d.c.) uses a 3 phase 12 pulse (2 x 6 pulse), fully-controlled SCR bridge rectifier system to convert the incoming mains supply into a regulated d.c. busbar (432V d.c. for a 380V a.c. input; 446V d.c. for a 400V a.c. input or 459V d.c. for a 415V a.c. input).

The input a.c. supply is applied (a) directly into a six pulse rectifier and (b) via a 30° phase shift transformer into a second six pulse rectifier (see figure 1-2). This phase shifting results in less distortion of the alternating

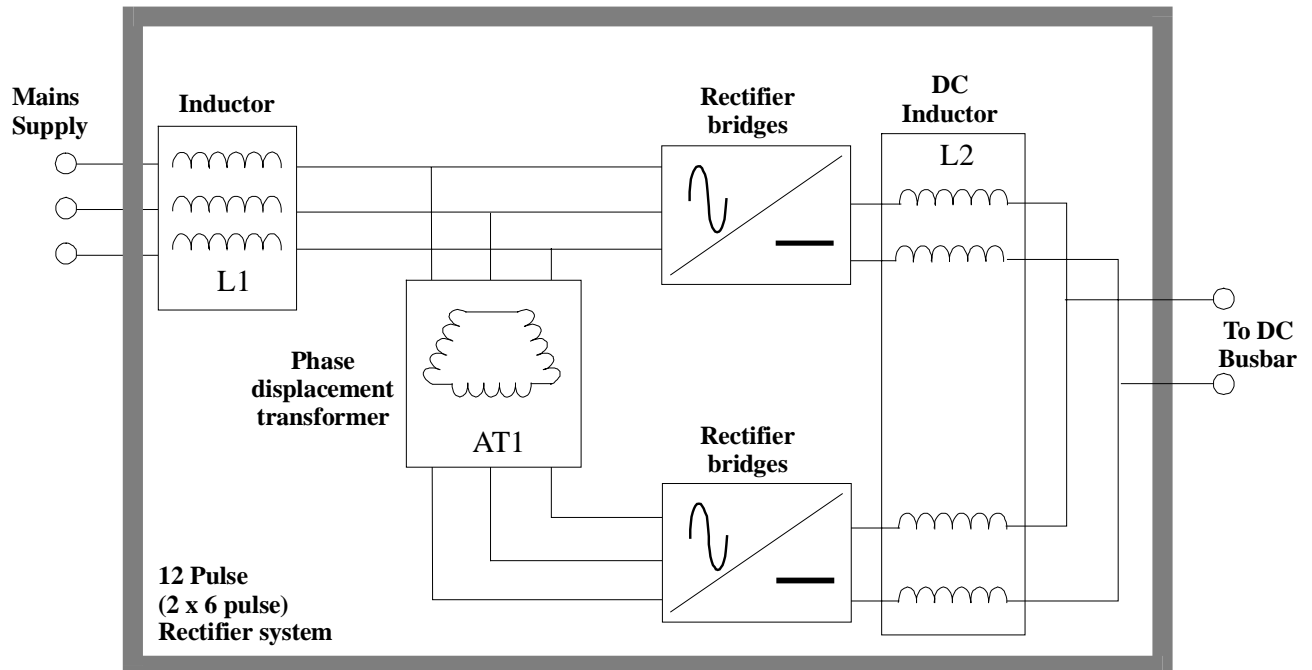

Figure 1-2 . 12 Pulse rectifier block diagram

input supply (i.e. the lower order harmonics are cancelled).

**Inverter**

The d.c. busbar produced by the rectifier provides both battery charging power and power to the inverter section-which uses the latest IGBT switched pulse width modulation (PWM) design and provides the second conversion phase; i.e. reconverting the d.c. busbar voltage back into an a.c. voltage waveform.

During normal operation both the rectifier and inverter sections are active and provide regulated load power whilst simultaneously float charging the battery. In the event of a mains power failure, the rectifier becomes inoperative and the inverter is powered solely from the battery. Critical load power is maintained under these conditions until the battery is fully discharged, whereupon the UPS shuts down. The end of battery discharge is assumed when the battery voltage falls to 320 Vd.c. for a system with a 380V a.c. input supply, 330V d.c. with a 400V a.c. input supply and 340V d.c. with a 415V a.c. input supply.

The period for which the load can be maintained following a mains power failure is known as the system's 'Autonomy Time' and is dependent upon both the battery A/Hr capacity and the applied percentage load. It is usual in larger installations to provide an alternative UPS input power source from a standby generator when the

mains supply fails. Once such a generator has been brought on-line, and the UPS input power has been re-established, the batteries

immediately begin to recharge. Modern generators can be started and brought on-line very quickly and where such a facility is incorporated into the UPS installation it results in short battery discharge periods and correspondingly rapid recharge times.

### 1.2.2 Bypass supplies

The circuit block annotated 'Static Switch' in figure 1-3 contains an electronically controlled switching circuit which enables the critical load to be connected either to the inverter output or to a bypass power source via the 'static bypass line'. Normally, the load is connected to the inverter; but in the event of a UPS overload, or inverter failure, it is automatically transferred to the static bypass line due to the static switch action.

To provide a clean (no-break) load transfer between the inverter output and static bypass line, the inverter output and bypass supply must be fully synchronised during normal operating conditions. This is achieved through the inverter control electronics which make the inverter frequency track that of the static bypass supply-provided that the bypass remains within an acceptable frequency window. The synchronising window is pre-selected to 2% of nominal frequency, giving an acceptable frequency window of  $\pm 1\text{Hz}$ .

An [INVERTER UNSYNCHRONIZED] warning message is displayed on the operator control panel when the inverter and bypass supplies are not synchronized.

A second, manually controlled, 'maintenance bypass' supply is also incorporated into the UPS design. Its purpose is to enable the critical load to be powered from the mains (bypass) supply while the UPS is shut down for maintenance or troubleshooting.

*Note:-* The load is unprotected against mains power supply aberrations or failure when it is connected to *either* the static bypass or maintenance bypass supply.

### 1.2.3 UPS Power Switch Configuration

The power switch locations in the various 7400 models are shown in Figure 1-4. Figure 1-3 illustrates the 7400 series UPS module power switches in what is known as a "Split Bypass" configuration. This is the standard configuration for all models in the 7400 range.

In the "Split Bypass" configuration the static bypass line is switched by a separate isolator to a dedicated 'bypass' power source which also feeds the maintenance bypass line.

With the exception of the maintenance bypass isolator, all the isolators shown must be closed during normal UPS operation.

Although it cannot be classified as a 'power switch', the reset switch may be used as part of the UPS operating procedure. Fitted to the UPS Logic Board, the reset switch is used by the operator to re-transfer the load to the inverter following a detected overload or over temperature fault.

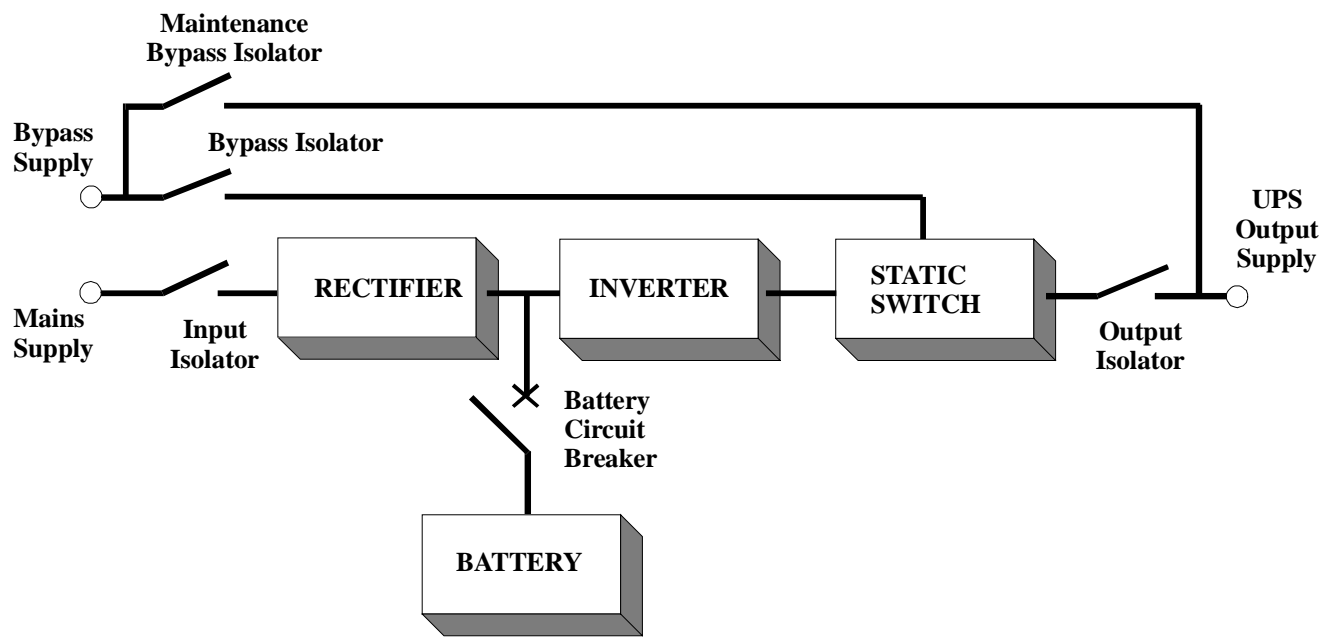

Figure 1-1 . Series 7400 UPS isolator configuration

**1.2.4 Battery circuit breaker** The battery is connected to the d.c. Busbar through a circuit breaker fitted inside the battery cabinet or located adjacent to the batteries where a battery cabinet is not used. This circuit breaker is closed manually, but it contains an undervoltage release coil which enables it to be tripped from the UPS control electronics following certain detected faults. It also has a magnetic trip facility for overload protection.

**1.2.5 Battery Cabinet** In the case of the 80kVA and 120kVA UPS models, the batteries associated with the UPS are generally housed in a purpose-built cabinet located along-side the main UPS equipment. It is possible to install batteries of various types and capacity in the cabinet to obtain the required autonomy characteristics.

- The battery cabinet can be purchased in one of the following forms:
1. Complete installation comprising the battery cabinet, batteries and circuit breaker.
  2. Battery cabinet and circuit breaker only — with no batteries.
  3. Battery cabinet only — with no batteries or circuit breaker.

**1.2.6 Battery circuit breaker box** For the larger units and as an alternative to the battery cabinets, a battery circuit breaker can be provided in a custom built box. This Battery Circuit Breaker Box is designed to be wall or rack mounted and is connected between the UPS and Battery.

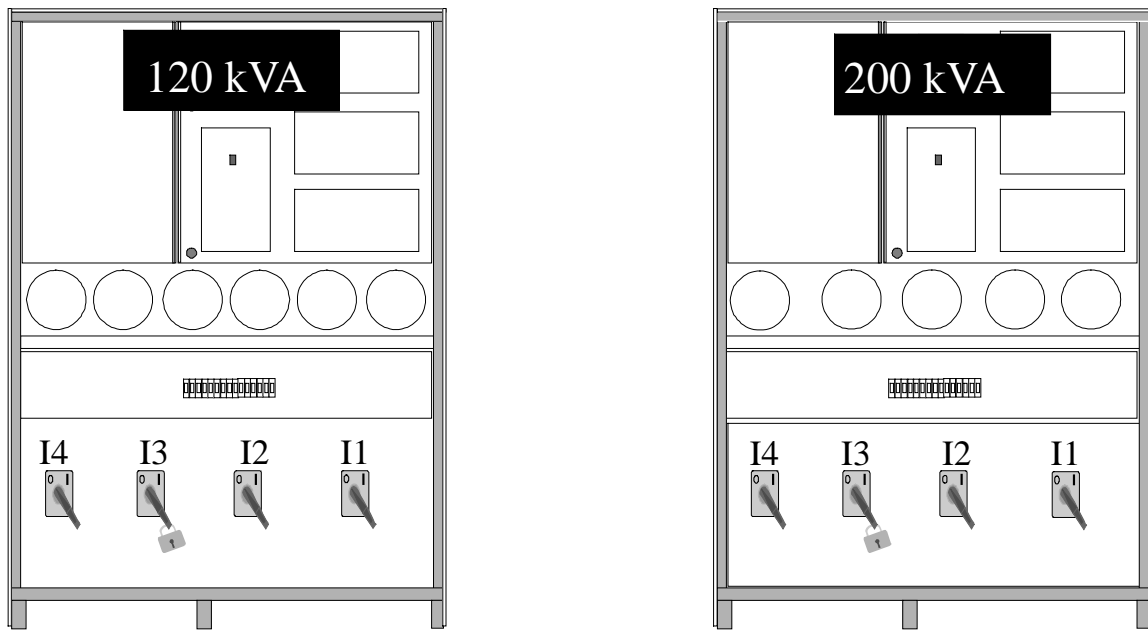

- I1 = Input Isolator
- I2 = Static Bypass Isolator
- I3 = Maintenance Bypass Isolator (with padlock)
- I4 = Output Isolator

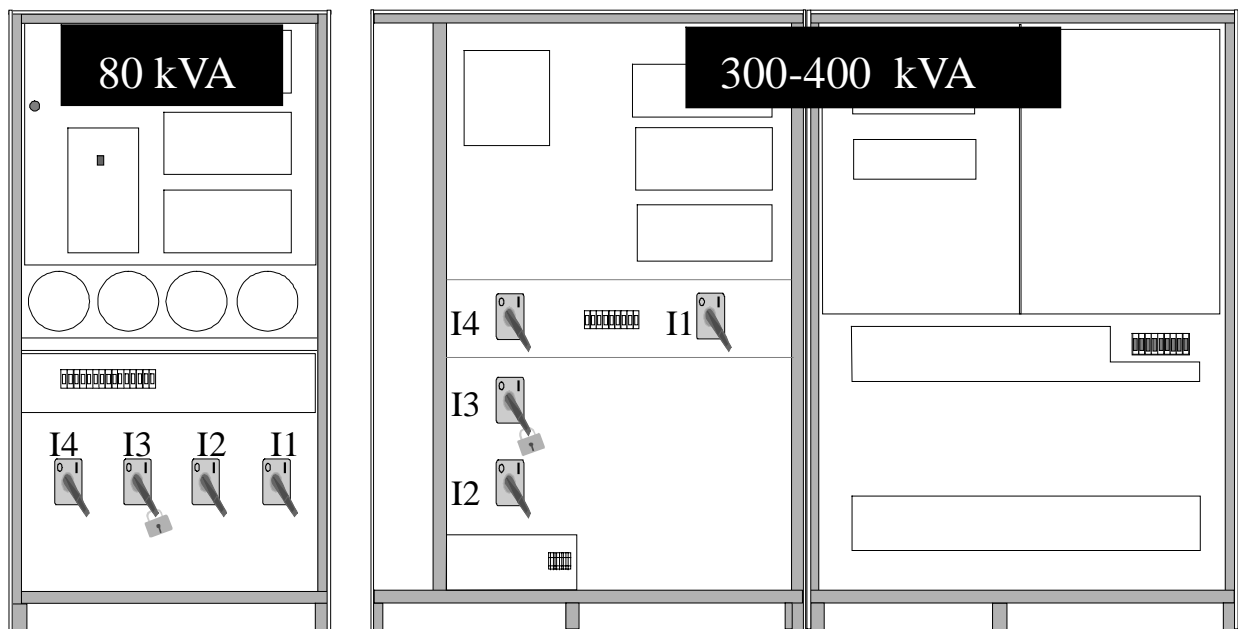

Figure 1-1 . Power isolator identification

---

## 1.3 One Plus One System

---

The *one-plus-one* system comprises two standard 7400 series UPS modules which are modified to allow their outputs to be connected in parallel. These can then be used in a "redundant" or "non-redundant" configuration as explained below.

### 1.3.1 Redundant vs Non-Redundant configuration

In a non-redundant module configuration, the system is sized such that both UPS modules are required to feed the potential load, and if one of the two modules develops a fault, or is for some reason shut down, the other module automatically shuts down also.

*Note:* In such an event the load is transferred to an unprocessed bypass supply -as described later.

In a redundant module configuration the system is sized such that the potential load can be provided by just one of the two modules. Under normal circumstances both modules are operational and share the load current equally; but if one module develops a fault, or is shut down, the second module is able to take over the full load demand and continue to provide it with processed, backed-up power. The advantages of a redundant system over a non-redundant system in terms of overall system reliability are self evident.

Changing a *one-plus-one* system's configuration between redundant and non-redundant is quite straightforward, being carried out by configuration links on the circuit board which governs the modules' parallel control operation.

### 1.3.2 One-Plus-One Parallel Control

When two of the standard 7400 modules just described are connected together to form a *one-plus-one* system, each module is fitted with an additional circuit board which allows the two modules to communicate with each other. Communication takes place via a single ribbon cable connected between the modules as illustrated in figure 1-5. The inter-module parallel control responsibilities are complex but can be summarised as follows:

*Synchronisation:*

As the outputs from both UPS modules are connected together to provide a single load supply, it is imperative that the inverters are fully synchronised both in frequency and phase. This is achieved by digitally locking the two inverter control oscillators. Similarly, as has already been mentioned, it is necessary for the inverters to be synchronised to the bypass supply to enable a "no-break" transfer to be achieved when the static switch transfers the load to the bypass supply. The inverter control oscillators are therefore not only locked together but are also made to track the bypass frequency.

*Current sharing:*

The parallel control circuit compares the module's output current with that of its partner and is thereby able to effect current sharing between the modules by making fine adjustments of an individual module's output voltage.

*Redundancy configuration:*

A link in the parallel control logic determines whether the one-plus-one system operates in a "redundant" or "non-redundant" configuration.

If a non-redundant mode is selected the two static switch sections are effectively locked together in that both static switches are turned off or on by a single control signal. Thus if one module develops a fault, when running, its static switch control logic will transfer its output from the inverter to the static bypass line and simultaneously send a signal to the static switch control logic in the second module to do likewise.

This does not happen if the system is configured as a redundant system, in which case the second module is allowed to continue supplying the load from its inverter when the first module trips its inverter off line.

*Reverse current:*

A reverse current monitor circuit detects current flowing into, rather than out of, the module's output terminals. Such a condition can arise if a module develops an internal power fault or if for some reason the two modules become unbalanced, and is liable to further damage the module and also degrade the load supply. If a reverse current is detected the inverter on the affected module is immediately shut down and (depending on the system redundancy configuration) the load is transferred to the bypass supply "Non-Redundant system", or remains on the good inverter "Redundant system".

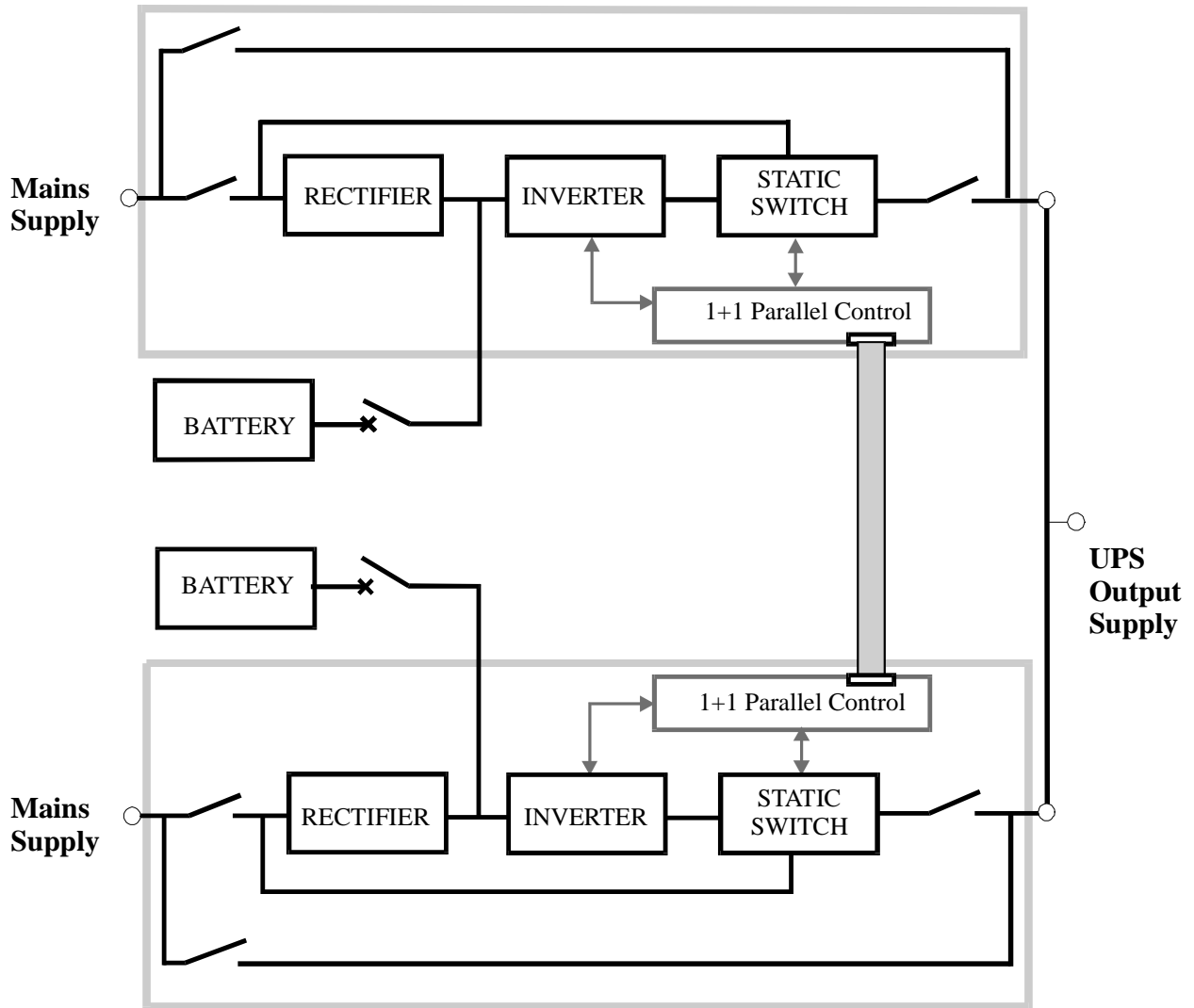

Figure 1-1 . Parallel control in a one-plus-one system

### 1.3.3 Common battery

The illustration in figure 1-5 shows a dedicated battery installation for each module; however, it is possible to fit an option kit which allows the two modules in a one-plus-one system to share a common battery. Such an installation is shown in figure 1-6 overleaf.

Note: the "Common battery" configuration is possible with 6 pulse rectifiers only, **not** with 12 pulse rectifiers.

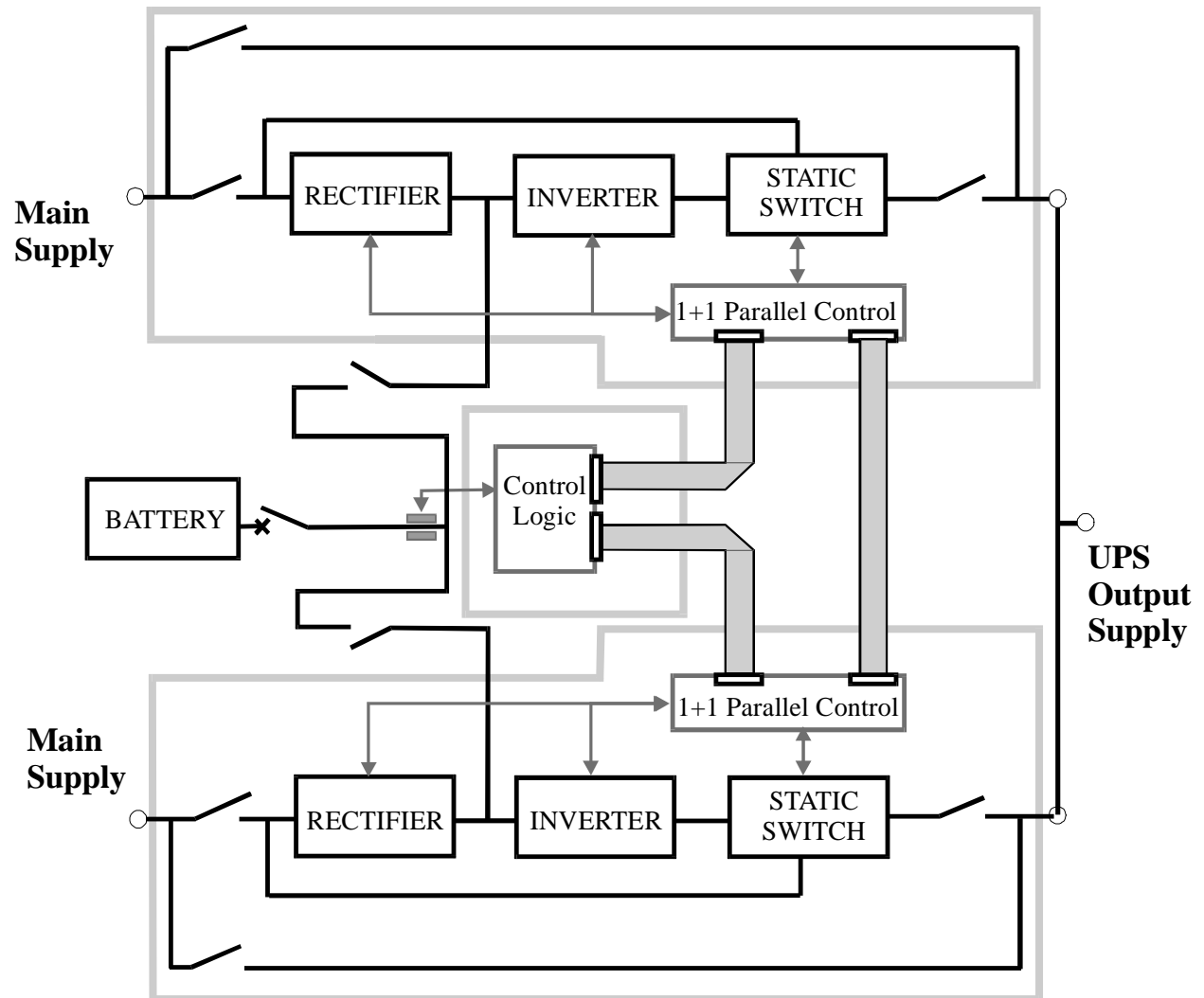

Figure 1-1 . "Common battery" configuration

The "Common Battery" option kit contains a DCCT (d.c. Current Transformer) in series with the battery, which replaces the equivalent DCCT's inside the UPS's (these are inhibited).

To ensure balance of the rectifiers output currents a link on the Parallel control p.c.b. interconnects the control circuits of the two rectifiers.

The components used by the "Common Battery Option" are contained in a separate cabinet known as the Common Battery Panel.

## 1.4 Operator Control Panel

The operator control panel is divided into three functional areas; 'mimic indications', 'control switches', and 'LCD display panel'.

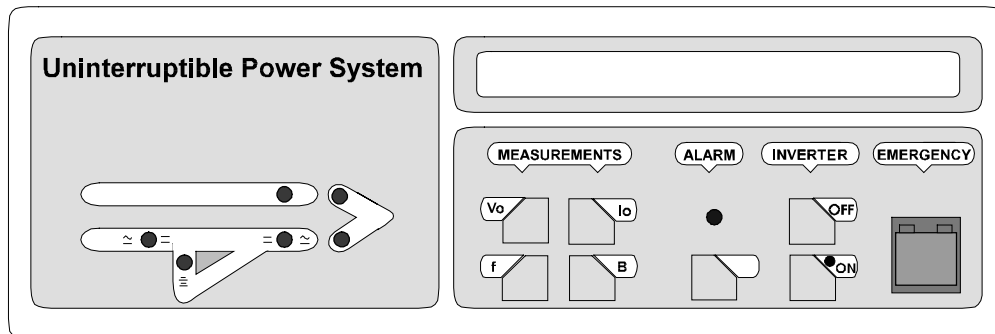

Figure 1-1 . Operator control panel

### 1.4.1 Mimic indications

Six leds are mounted on a single line diagram to represent the various UPS power paths. These leds, which are annotated in figure 1-8, show the current UPS operational status and should be interpreted as detailed below.

*LS1 - Input supply OK / Rectifier operative:*

This led illuminates when the input isolator (I1) is closed, the input supply is within 20% of nominal voltage, and the rectifier is operative.

*LS2 - Battery volts OK:* This led illuminates when the battery circuit breaker is closed and the battery voltage is within the UPS operating range (320V - 490V nominal).

*LS3 - bypass supply OK:* This led illuminates when the static bypass supply is within  $\pm 10\%$  of its nominal voltage.

*LS4 - Inverter output OK:*

This led illuminates when the inverter is operating and its output is within a preset ( $\pm 10\%$ ) acceptable voltage window.

*LS5 - Load on bypass*

This led illuminates when the output isolator is closed and the load is connected to the bypass supply via the static switch.

*LS6 - Load on inverter:*

This led illuminates when the output isolator is closed and the load is connected to the inverter via the static switch.

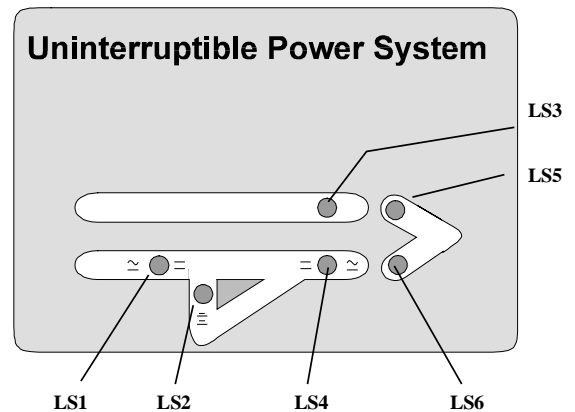

Figure 1-1 . Mimic panel

### 1.4.2 Control switches

Seven tactile switches are located on the Operator Panel, together with an emergency stop pushbutton which is fitted with a safety cover to prevent inadvertent operation.

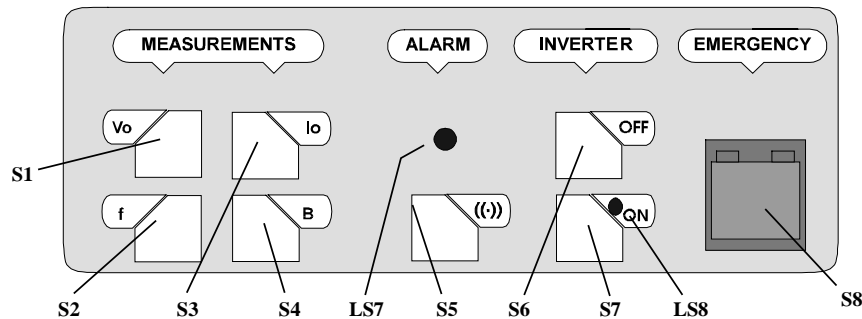

Figure 1-1 . Control panel switches

#### Switch S1 (Vo) - Output volts:

When this switch is pressed, the lower line of the LCD Display shows the output line-to-line voltages on all three phases.

#### Switch S2 (Fo) - Output frequency:

When this switch is pressed, the lower line of the LCD Display shows the output frequency.

#### Switch S3 (Io) - Output current:

When this switch is pressed, the lower line of the LCD Display shows the output line (and neutral) currents.

#### Switch S4 (B) - Battery:

When this switch is pressed, the lower line of the LCD Display shows the battery voltage, current and % charge or autonomy time remaining in minutes. Note that a discharging current is symbolised by a preceding minus [—] sign.

#### Switch S5 - ((.)) - Alarm reset:

Pressing this switch cancels the audible alarm. The alarm led and messages will remain active if a detected fault condition is still present.

#### Switch S6 - Inverter OFF:

Pressing this switch turns OFF the inverter and causes the load to be transferred to the static bypass supply.

#### Switch S7 - Inverter ON:

Pressing this switch activates the inverter and causes the load to be transferred to the inverter side of the static switch after the inverter voltage has had time to stabilise.

#### Switch S8 - Emergency stop:

When the emergency stop switch is pressed it disables the static switch block entirely (so removing load power). It also disables the rectifier and inverter, and trips the battery circuit breaker. Under normal circumstances it does not remove UPS input power since this is applied through a manually controlled isolator; however, if the UPS input supply is connected via a circuit breaker having an electrical trip facility the emergency stop signal can be used to drive the external circuit breaker's trip circuit.

There are two leds contained within the switch panel area:

#### LS7 - Alarm:

This led accompanies the audible alarm warning when any alarm condition is initiated. The audible warning can be cancelled by the reset switch (S5) but LS7 will only extinguish after the alarmed condition has reverted to normal.

*LS8 - Inverter status:*

This green led situated near the inverter ON switch illuminates when the inverter is selected ON.

### 1.4.3 LCD Display

An LCD display, capable of showing two rows of 40 characters, is used to indicate the UPS operating parameters, warnings and alarms.

A DIP switch fitted to the display microprocessor board enables the displayed language to be easily selected to English, French, Italian, Spanish or German.

The lower row of characters are used to display metered parameters; which include output (or bypass) voltage, frequency, or current together with battery current, voltage and % charge or time remaining on battery.

Warning and alarm messages are displayed on the upper row of characters. The ALARM led and audible warning accompany all *alarm* messages but are not activated by *warning* messages. In all cases, the message automatically resets when the alarmed (or warning) condition reverts to normal.

When two (or more) alarm or warning conditions are active simultaneously, the appropriate messages are displayed in a cyclic fashion, with each message appearing on the display for approximately 10 seconds.

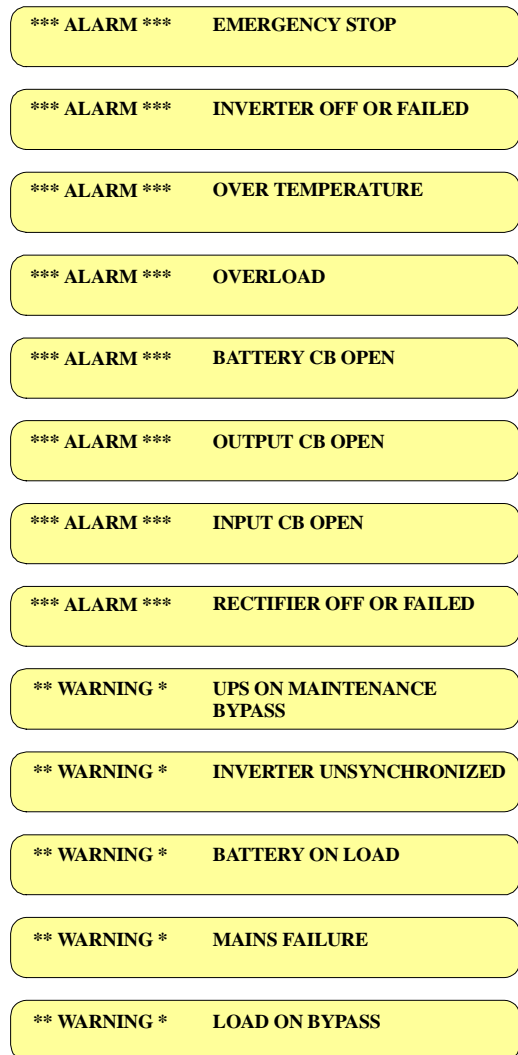

Figure 1-1 .Display messages

#### **Battery condition display**

You can display the relative condition/state of the battery as a % of the nominal capacity with the input a.c. power supply present by pressing switch 4 ('B'). The time remaining on battery is automatically displayed in minutes during a input ac power supply failure.

On first installation or on the installation of a new battery the nominal capacity of the battery must be entered into the system software (see chapter 3).



---

## 2. Chapter 2 - Operating Instructions

---

### 2.1 Introduction

---

The UPS can be considered to be in one of three operating conditions:

- Shutdown - All power isolators and circuit breakers open - no load power.
- On Maintenance Bypass - UPS shut down but the load connected to the unprotected mains via the Maintenance Bypass Supply line.
- Normal operation - All relevant power isolators and circuit breakers closed, the load is powered by the UPS.

This chapter contains detailed instructions to enable you to switch between these three conditions.

#### 2.1.1 General notes

*Note 1:* All the user controls and indicators mentioned in these procedures are identified in chapter 1 (figures 1-3, 1-4, 1-7, 1-8 and 1-9).

*Note 2:* The audible alarm may annunciate at various points in these procedures. It can be cancelled at any time by pressing the 'Alarm Reset' pushbutton.

*Note 3:* The 7400 series UPS incorporates an optional automatic boost charge facility which can be used in systems containing non-sealed lead-acid batteries. If this type of battery is used in your installation you may notice that the battery charger voltage will be greater than its normal value when the mains supply returns from a prolonged outage. The revised voltage will be 460V d.c. for a 380V a.c. system, 475V d.c. for a 400V a.c. system and 490V d.c. for a 415V a.c. system. This is the normal response of the boost charge facility: the charger voltage should return to normal after a few hours.

### 2.2 One plus One

---

Starting and stopping the *one-plus-one* system is the same as a single module, however the modules' response depends on whether it is configured as a Redundant or Non-Redundant system. The operating procedures are the same irrespective of the selected redundancy mode; in simple terms you start (stop) one module and then repeat the operation on the second module.

The difference in the system response concerns the point at which the load is transferred between the bypass and uninterruptible (i.e. inverter) supplies and is summarised below:

#### 2.2.1 Redundant module system

*Starting:*

When starting a redundant module system the load is transferred from the bypass to the inverter of the first module as soon as the first module is started and its inverter is brought on line. When the second module is started its static bypass line is totally inhibited due to the first module being on line, and the second module will not be connected to the load until its inverter is operational and fully synchronised with the first module.

*Stopping:*

When the first module is stopped its static bypass is inhibited because the load will be fully maintained by the inverter of the second module.

When shutting down the second module, the static bypass lines of both modules will be turned on as soon as its inverter is stopped. That is, both modules will provide load power through their paralleled bypass lines.

**2.2.2 Non-Redundant module system**

*Starting:*

In a Non-Redundant module system both modules must be running before the load is transferred to their paralleled inverters. Therefore, when the first module is started, the load will remain connected to its static bypass line while waiting for the second module to synchronise.

*Stopping:*

The load will be transferred to the static bypass lines in both modules simultaneously as soon as the inverter stops in the first module to be shut down.

**How to turn on the system from a shutdown condition**

This procedure should be followed when turning on the UPS from a fully powered down condition - i.e. where the load is not being initially supplied through the internal Maintenance Bypass supply.

Note: For a *one plus one* system, complete these actions on one module at a time.

Step	Action	Response
1.	Close the module's Output Isolator and check that the UPS input mains supply (and bypass supply if separate) is turned on externally.	
2.	Close the Input Isolator and Static Bypass Isolator .	<p><b>Mimic panel leds</b> LS1 LS3 and LS5 should illuminate immediately, to indicate that the load is being supplied through the static bypass line. (NB: In a one plus one Redundant Module system LS5 will not illuminate on the second module to be started as its static bypass line is inhibited).</p> <p>The inverter should start automatically once the d.c. Busbar reaches its working voltage (after about 30 seconds), and when this occurs LS4 (inverter OK) will illuminate followed by LS6 (load on inverter). (NB: In a one plus one Non-Redundant module system LS6 will not illuminate on the first module to be started until you reach this point in starting the second module.)</p> <p>Note that LS5 will extinguish when LS6 illuminates.</p>
3.	Wait 20 seconds then close the battery circuit breaker: This is located inside the battery cabinet (if used) or is otherwise located adjacent to the battery racks	<p><b>Mimic panel leds</b> LS2 should illuminate on the mimic panel and LS7 (alarm) should extinguish.</p>
4.	Press the battery metering selector switch [B]:	The display should indicate a positive (+) battery charging current.

## How to turn on the system from a maintenance power-down condition

This procedure should be followed to start the UPS from a MAINTENANCE power-down condition - i.e. where the load is being initially powered through the internal maintenance bypass supply.

**Note:** For a *one plus one* system, complete these actions on one module at a time.

Step	Action	Response
1.	Check that the UPS input mains supply (and bypass supply if separate) is turned on externally.	
2.	Close the Input Isolator and Static Bypass Isolator.	<p><b>Mimic panel leds</b> LS1 and LS3 should illuminate immediately, to indicate that the input and bypass supplies are healthy.</p> <p>The inverter should start automatically once the d.c. Busbar reaches its working voltage (after about 30 seconds), and when this occurs LS4 (inverter OK) will illuminate</p>
3.	Wait 20 seconds then close the battery circuit breaker: This is located inside the battery cabinet (if used) or otherwise adjacent to the battery racks.	<p><b>Mimic panel leds</b> LS2 should illuminate.</p>
4.	Press the battery metering selector switch [B]:	The display should indicate a positive (+) battery charging current.
5.	Press the Inverter OFF pushbutton (S6). ( On both modules for a 1 + 1 system ).	<p><b>Mimic panel leds</b> LS4 should extinguish.</p>
6.	Close the Output Isolator. ( On both modules for a 1 + 1 system ).	<p><b>Mimic panel leds</b> LS5 should illuminate to indicate that the load is connected to the static bypass line. <i>(On both modules for a 1 + 1 system).</i></p>
7.	Open the Maintenance Bypass Isolator ( <i>on both modules in a one plus one system</i> ) then Press the Inverter ON switch (S7) ( <i>on both modules in the one plus one system</i> ). (NB: The inverters of both modules are inhibited if either modules' Maintenance Bypass Isolator is closed.)	<p><b>Mimic panel leds</b> LS4 (Inverter OK) and LS6 (Load on inverter) should illuminate after approximately 30 seconds. <i>(NB: In a one plus one Non-Redundant module system LS6 will not illuminate on the first module to be started until you reach this point in starting the second module.)</i>.</p> <p>LS5 should extinguish at the same time as LS6 illuminates. LS7 (alarm) should extinguish.</p>

## How to turn off the system but continue to provide load power through the maintenance bypass

This procedure should be followed if the UPS is to be powered-down while continuing to supply the load through the maintenance bypass line. Note that during this procedure the load will be unprotected against mains supply disturbances once the inverter(s) has been switched off.

Step	Action	Response
1.	Ensure that LS3 is illuminated on the mimic panels (indicating that the static bypass supply is healthy).	
2.	Press the Inverter OFF switch (S6) ( <i>on both modules in the one plus one system</i> )	Mimic panel leds LS4 and LS6 should extinguish (on both modules in the one plus one system) and LS5 should illuminate to show that the load has been transferred to the static bypass line. <i>Note: On a one plus one redundant system both Inverter OFF switches (S6) must be operated before LS5 illuminates but in a non-redundant system the Inverter OFF switch must be pressed on one module only before LS5 illuminates. However, as the load is transferred to the static bypass, the second module should be turned OFF also.</i>
3.	Close the Maintenance Bypass Isolator ( <i>on both modules in the one plus one system</i> ).	Mimic panel leds No change.
4.	Open the Output Isolator ( <i>on both modules in the one plus one system</i> ).	Mimic panel leds LS5 should extinguish (on both modules in the one plus one system).
5.	(On each module in the one plus one system) — Open the battery circuit breaker followed by the Input Isolator and Static Bypass Isolator. On 80 - 120 - 200 kVA: open auxiliary fuses F1... F6 WAIT AT LEAST 5 MINUTES	All the operator panel led indications and messages should extinguish as the mains driven internal power supplies decay.

### WARNING

*Wait at least 2 minutes for the d.c. capacitors to discharge.*

*The following points will be live within the UPS:*

- Bypass supply input terminals -
- Maintenance Bypass Isolator switch -
- Static Bypass Isolator Switch (if fitted) -
- UPS output terminals -

## How to totally power-down the system

This procedure should be followed only if the UPS AND LOAD are to be completely powered down.

Step	Action	Response
1.	Press the Inverter OFF switch (S6) (on both modules in the one plus one system):	<b>Mimic panel leds</b> LS4 and LS6 should extinguish, and LS5 should illuminate to show that the load has been transferred to the static bypass line. (NB: in a Non-Redundant Module system LS5 and LS6 will also change-over on the second module).
2.	Open the battery circuit breaker:	<b>Mimic panel leds</b> LS2 should extinguish.
3.	Open the Input Isolator and Static Bypass Isolator. On 80 - 120 - 200 kVA open auxiliary fuses F1 ... F6	All the operator panel led indications and messages should extinguish as the mains driven internal power supplies decay.

### **IMPORTANT**

*The Maintenance Bypass Isolator may be operated at any time when the UPS is powered down to connect/disconnect the load to the raw maintenance bypass supply if required.*

### **Emergency stop**

*The emergency stop pushbutton is located behind a hinged safety shield to prevent inadvertent operation. When this switch is pressed modules are electronically shut down and battery circuit breakers are tripped. Power is removed from the critical load, but pressing the emergency stop pushbutton **will not** remove the modules' input mains supply unless an external contactor, controlled via the emergency stop pushbutton auxiliaries, is fitted in the mains supply line..*





## 3. Chapter 3 - Installation Procedure

### 3.1 Introduction

#### **WARNING**

*Do not apply electrical power to the UPS equipment before the arrival of the commissioning engineer.*

#### **WARNING**

*The UPS equipment should be installed by a qualified engineer in accordance with the information contained in this chapter and the drawing package shipped inside the UPS cabinet.*

#### **WARNING**

#### **Battery hazards**

*Special care should be taken when working with the batteries associated with this equipment. When connected together, the battery terminal voltage will exceed 400 Vd.c. and is potentially lethal.*

*Eye protection should be worn to prevent injury from accidental electrical arcs. Remove rings, watches and all metal objects.*

*Only use tools with insulated handles.*

*Wear rubber gloves.*

*If a battery leaks electrolyte, or is otherwise physically damaged, it should be placed in a container resistant to sulphuric acid and disposed of in accordance with local regulations.*

*If electrolyte comes into contact with the skin the affected area should be washed immediately.*

This chapter contains information regarding the positioning and cabling of the UPS equipment and batteries.

Because every site has its peculiarities, it is not the aim of this chapter to provide step-by-step installation instructions, but to act as a guide as to the general procedures and practices that should be observed by the installing engineer.

### 3.1.1 Equipment positioning and environmental considerations

The UPS cabinets can be moved by fork lift or crane. Fork lift apertures are provided in the sides of the base plate and are accessible after removing blanking covers fitted to the side panel ventilation grills. Roof-mounted eye-bolts are fitted to enable the cabinet to be crane-handled. These can be removed once the equipment has been finally positioned.

**Note:** In a 1 + 1 system the models should be positioned adjacent to each

other.

#### **WARNING**

*Ensure that the UPS weight is within the designated S.W.L. of any handling equipment. See the UPS specification for weight details.*

*Do not move the battery cabinet with the batteries fitted..*

The 300kVA and 400 kVA UPS modules are split into two cabinets, a Main Inverter cabinet and a Rectifier/Static Bypass cabinet, to allow easier transportation and positioning. Once finally positioned, the two cabinets have to be bolted together and the interlinking power and control cable connections made. It is therefore necessary to observe cabinet A & B positioning (see figures 3-5 and 3-6).

The UPS module should be located in a cool, dry, clean-air environment with adequate ventilation to keep the ambient temperature within the specified operating range. If necessary, a system of extractor fans should be installed to aid cooling-air flow, and a suitable air filtration system used where the UPS is to operate in a dirty environment.

#### **Cables**

All control cables whether screened or not, should be run, separate from the power cables, in metal conduits or metal ducts which are electrically bonded to the metalwork of the cabinets to which they are connected.

#### **Cooling air flow**

All the models in the 7400 range are force-cooled with the aid of internal fans. Cooling air enters the module through ventilation grills located at various parts of the cabinet and exhausted through grills located in the equipment roof. When the equipment is located on a raised floor, and bottom cable entry is used, additional cooling air also enters the UPS via the floor void.

#### **Clearances**

To allow adequate cooling air flow, you should position the equipment with the following space around the back and sides.

*80kVA-120 kVA Models* — 100mm minimum required in all cases.

*200/300/400 kVA Models* — 300mm minimum required in all cases.

The UPS modules do not require back-access for maintenance servicing; but, where space permits, a clearance of approximately 4 feet (1.2 metres) will ease access to some component parts. Clearance around the front of the equipment should be sufficient to enable free passage of personnel with the doors fully opened.

### 3.1.2 Raised floor installation

to the floor.

If the equipment is to be located on a raised floor it should be mounted on a pedestal suitably designed to accept the equipment point loading. The installation diagrams in the back of this manual identify the location of the holes in the base plate through which the equipment can be bolted

### 3.1.3 Battery Location

**Note:** Temperature is a major factor in determining the battery life and capacity. Battery manufacturers quote figures for an operating temperature of 20°C. Operating above this temperature will reduce the battery life, operation below this temperature will reduce the battery capacity. On a normal installation the battery temperature is maintained between 15°C and 25°C.

In 80kVA and 120 kVA module installations the batteries associated with the UPS equipment are usually contained in a purpose-built battery cabinet which sits alongside the main UPS equipment. Sealed, maintenance-free batteries are normally used in this type of installation.

Due to their increased capacity, the batteries associated with larger UPS installations are usually too big to be mounted in a single cabinet and are either rack mounted or fitted in multiple, or bespoke, battery cabinets. Such installations may utilise non-sealed lead acid cells, requiring regular attention and impose their own environmental requirements.

Pedestals are required for the battery cabinets when they are located on raised floors, in the same way as for the UPS cabinets.

The batteries are connected to the UPS through a circuit breaker which is manually closed and electronically tripped via the UPS control circuitry. If the batteries are cabinet-mounted this circuit breaker is fitted within the cabinet; however, if the batteries are rack-mounted or otherwise located remote to the main UPS cabinet then the battery circuit breaker must be mounted as near as possible to the batteries themselves, and the power and control cables connected to the UPS using the most direct route possible. Liebert offer a purpose-designed remote battery circuit breaker box, containing the circuit breaker and its necessary control board, as a standard option kit.

6310018a.02.doc

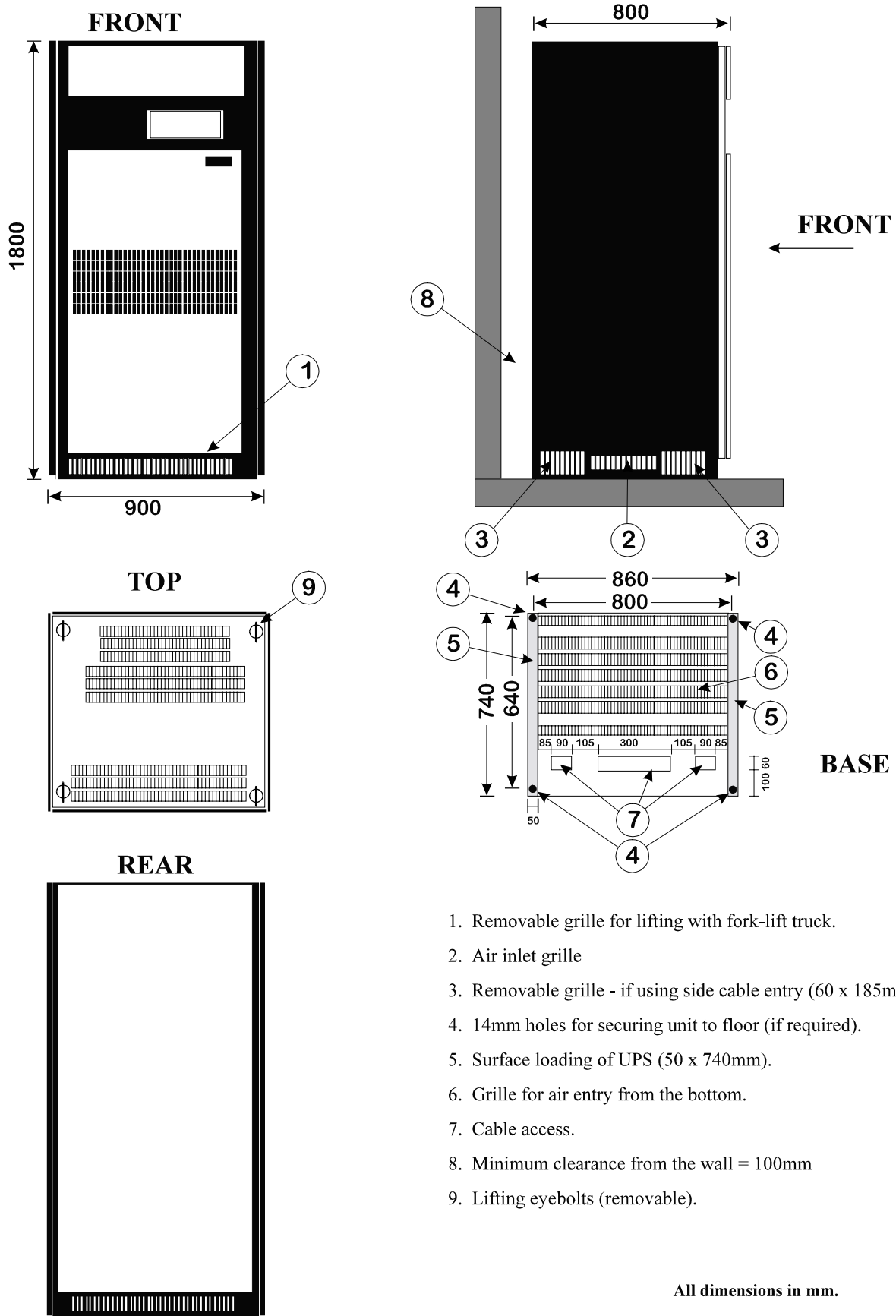

Figure 3-1 . Installation Diagram for 80 kVA Module

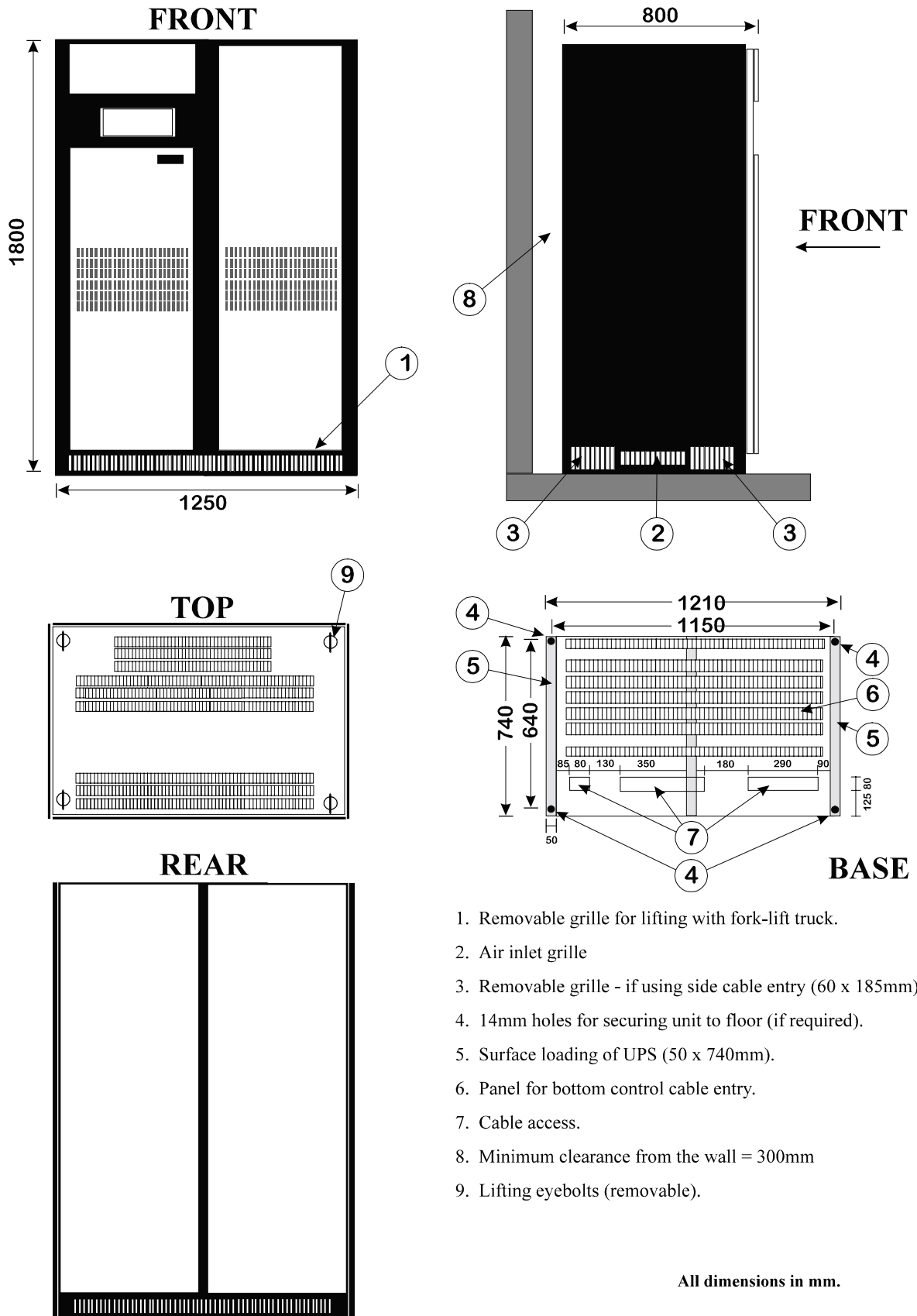

Figure 3-2 . Installation Diagram for 120 kVA Module



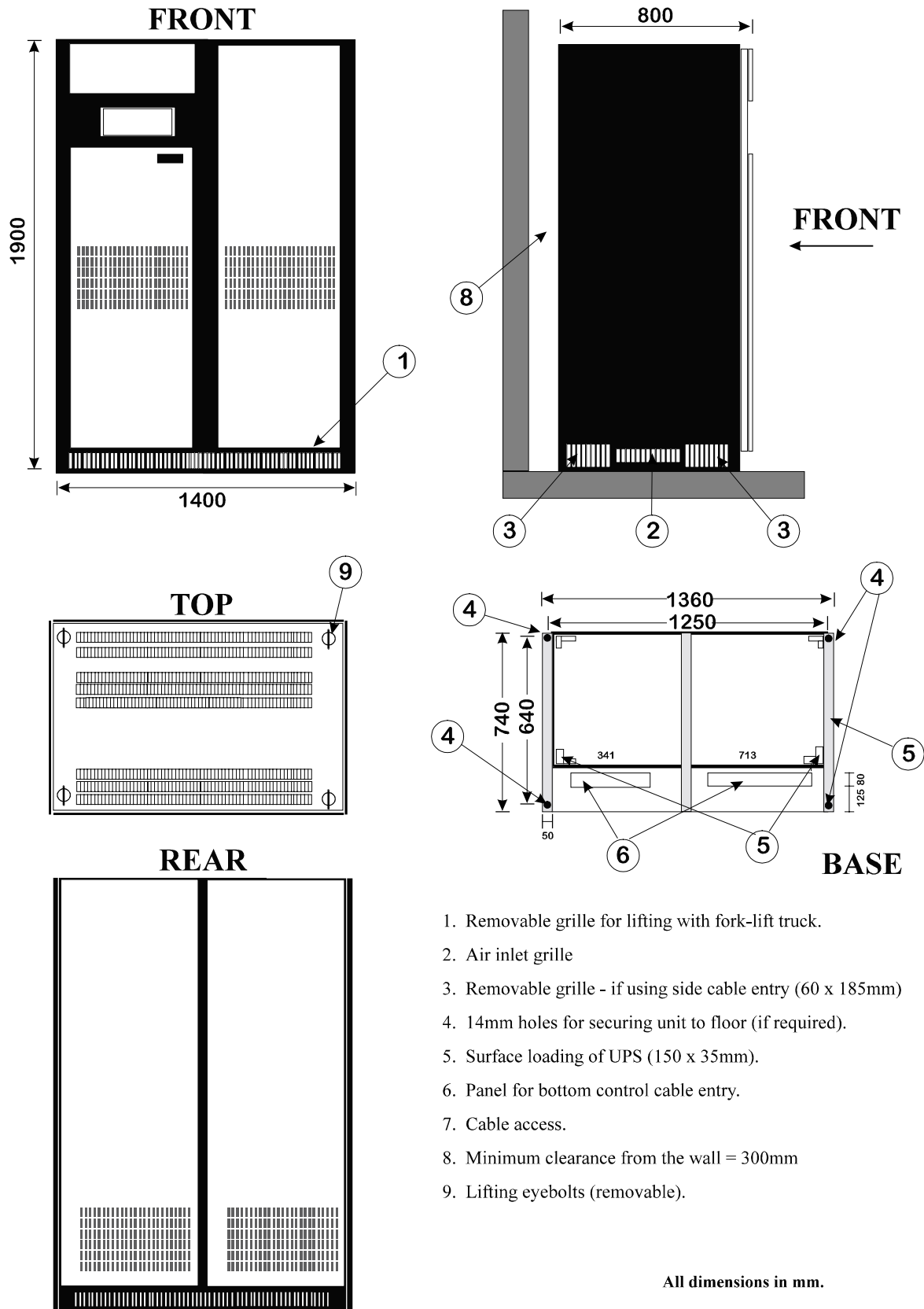

Figure 3-3 . Installation Diagram for 200 kVA Module

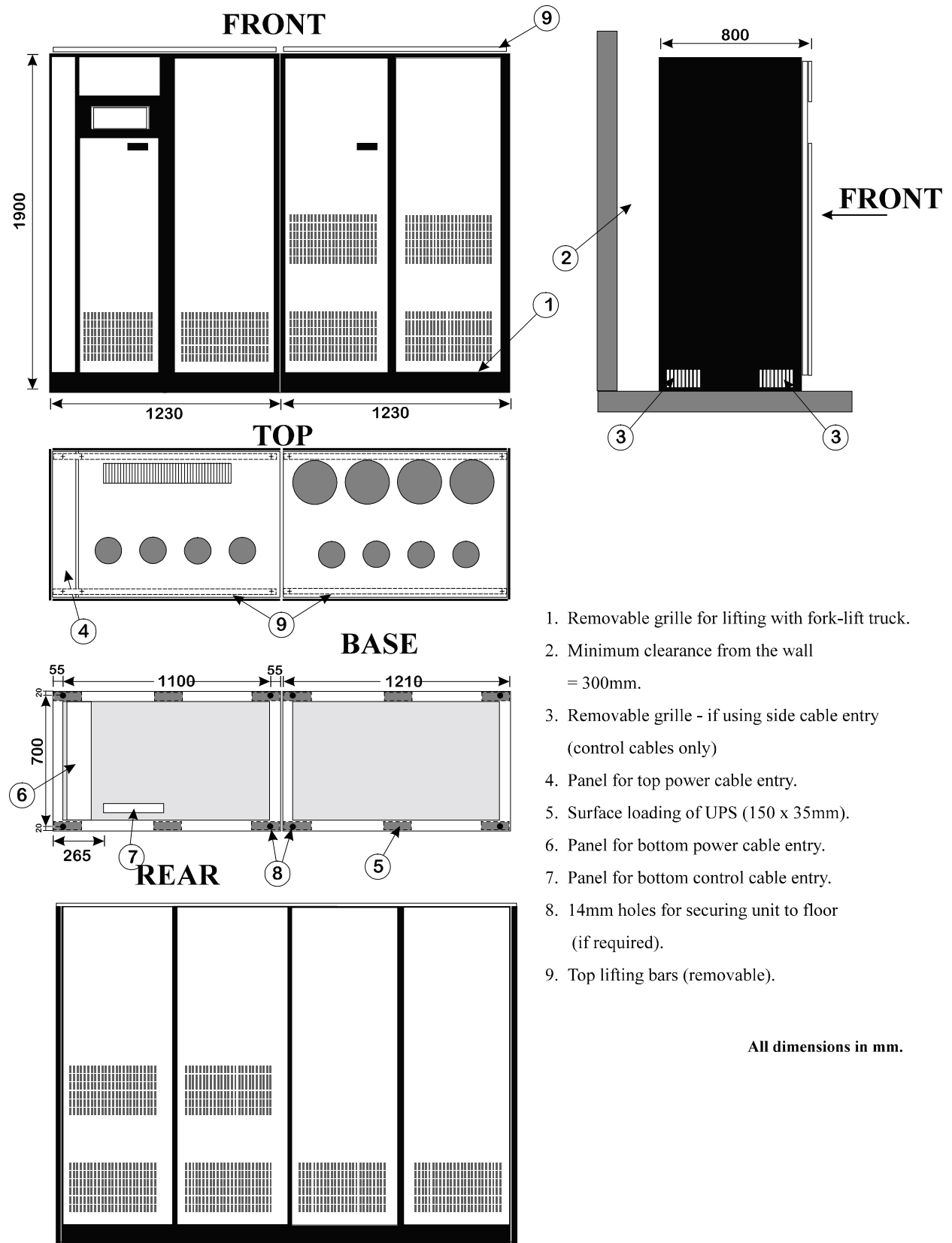
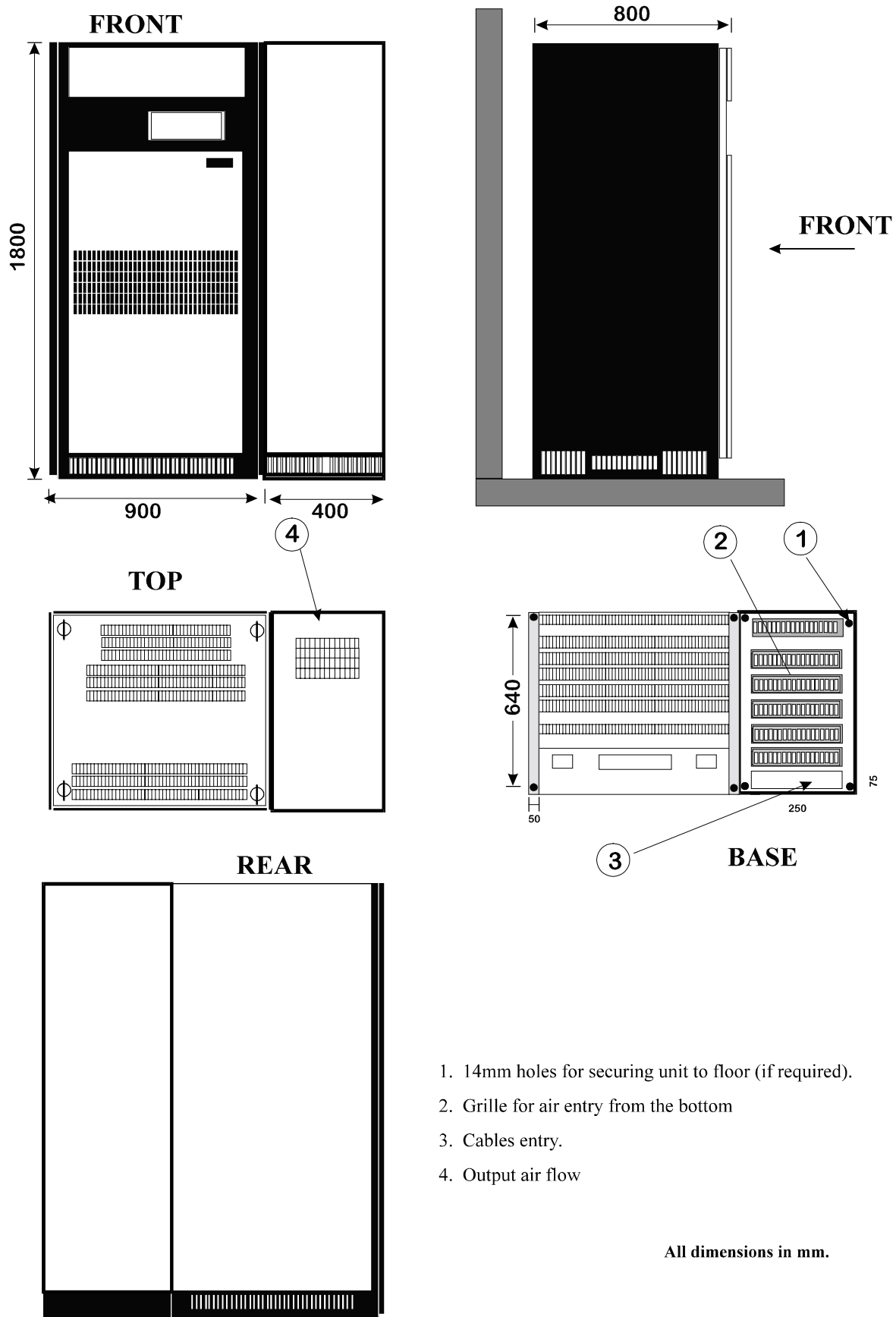

Figure 3-4 . Installation Diagram for 300/400 kVA Module 6 & 12



1. 14mm holes for securing unit to floor (if required).
2. Grille for air entry from the bottom
3. Cables entry.
4. Output air flow

All dimensions in mm.

Figure 3-5 . Inst. Diagram for 80 kVA Modules 12 Pulse

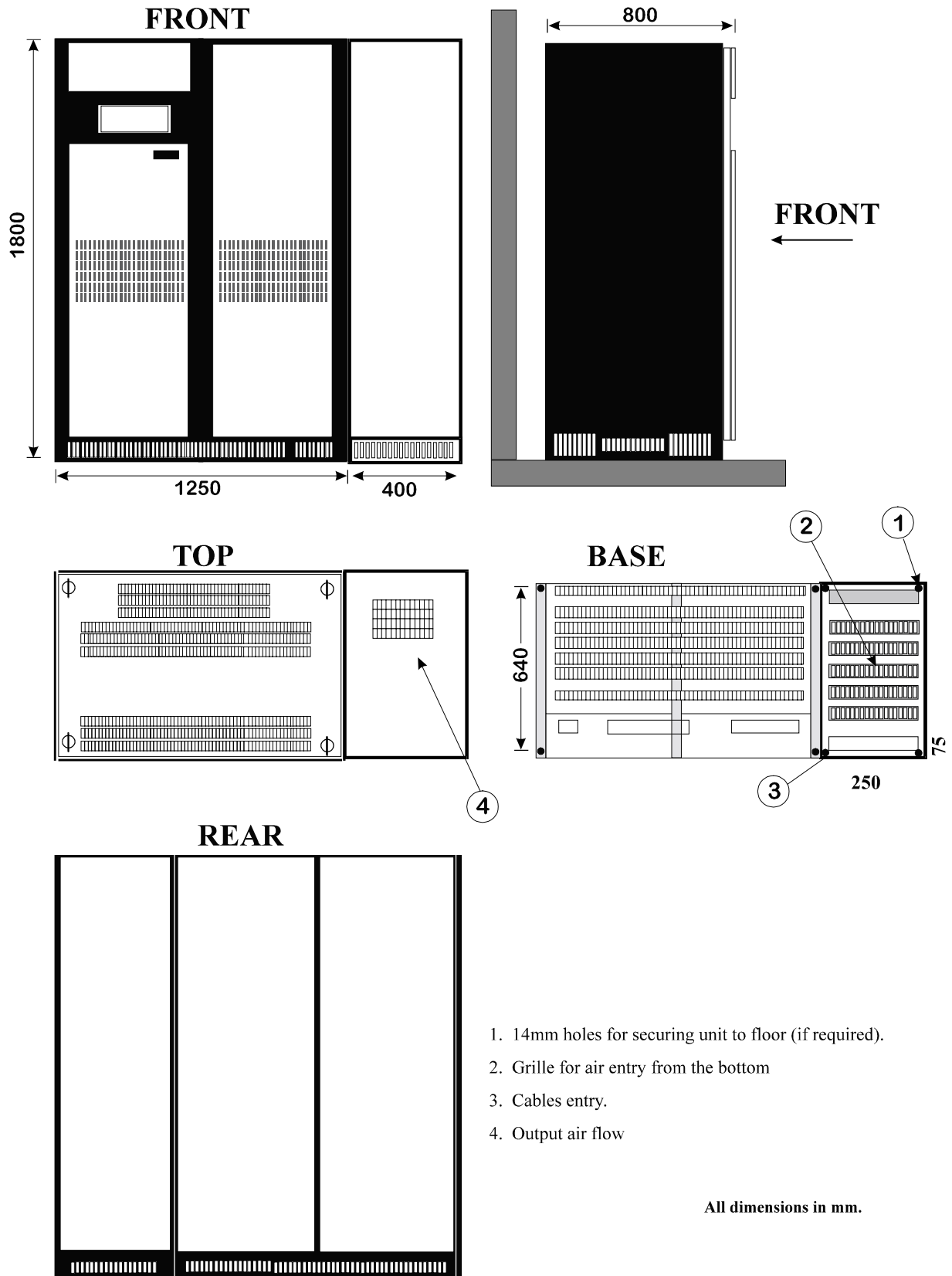

Figure 3-6 . Installation Diagram for 120 kVA Module 12 Pulse



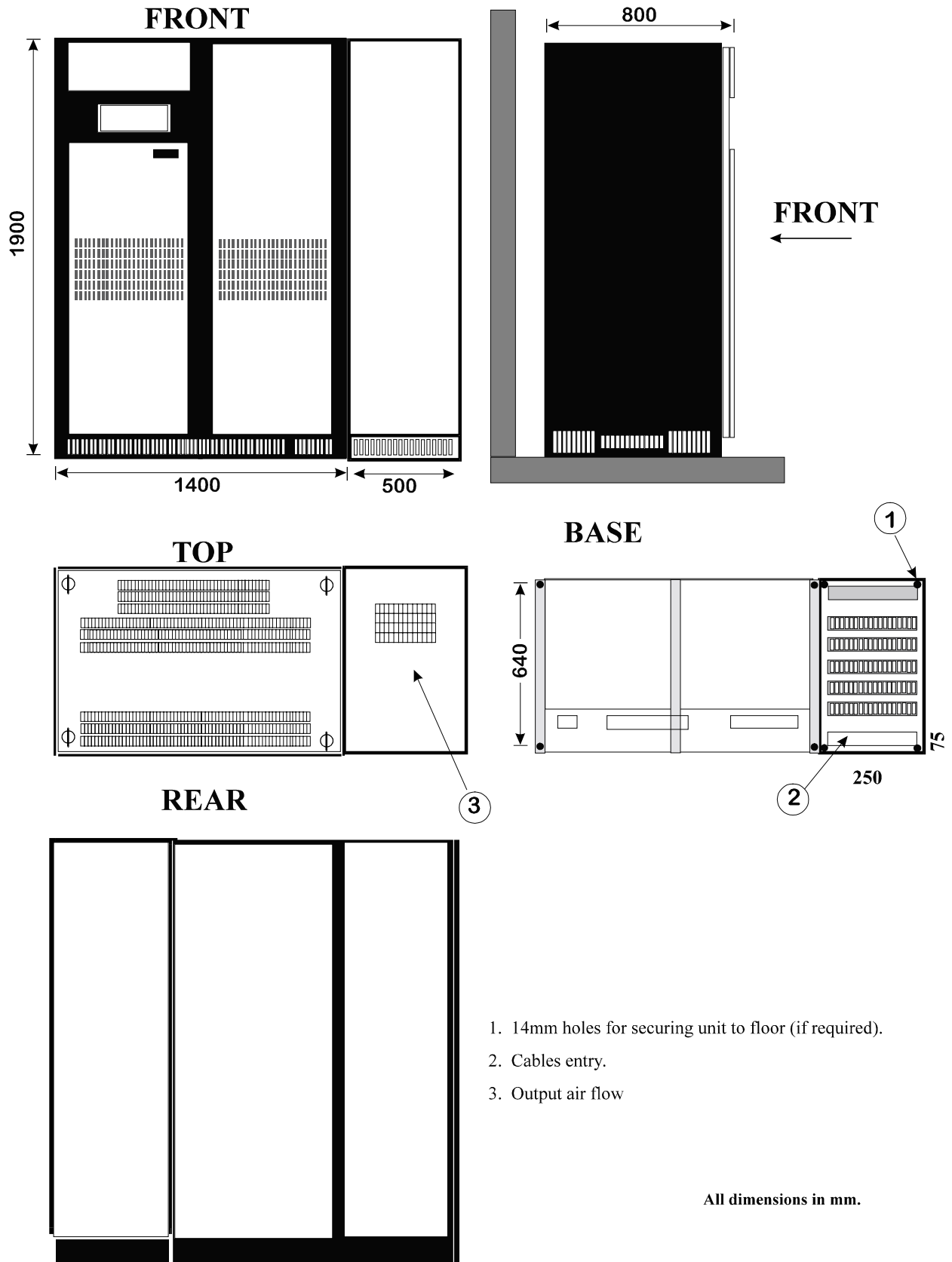

Figure 3-7 . Installation Diagram for 200 kVA Module 12 Pulse

## 3.2 Preliminary Checks

Before you install the UPS hardware you should carry out the following preliminary checks:

1. Verify that the UPS room satisfies the environmental conditions stipulated in the equipment specification, paying particular attention to the ambient temperature and air exchange system.
2. Remove any packaging debris then visually examine the UPS and battery equipment for transit damage, both internally and externally. Report any such damage to the shipper immediately.
3. Verify that the shipment is complete — e.g. that the battery contains the correct number of cells etc. Report any discrepancy immediately.
4. When you are satisfied that the equipment is complete and in good condition move it to its proposed final position.

*Note:* If 'side' cable entry is to be used (see below) ensure that the blanking plates are removed before finally fixing the cabinets in position.

5. All models have a stabilising bar fitted to the output transformer T1 during shipment, this should be removed when the UPS has been placed in its final position.

### ***Caution***

*Ensure the stabilising bar fitted to the output transformer T1 is removed before proceeding with the installation.*

### 3.3 Reassembling the 300 kVA and 400 kVA cabinets

Place the cabinets in their final position as shown in figure 3-6 ensuring any protective packaging is removed (Inverter Cabinet on the right and Rectifier/Static Switch Cabinet on the left), and connect them together following the procedure below:

#### **Caution**

*Ensure loose cables are not trapped between the two cabinet frames.*

1. Align the Rectifier/Static switch and Inverter Cabinets and bolt them together through the holes provided.
2. Open the doors to the Inverter cabinet and remove the lower protective cover to gain access to the a.c. busbars R, S, T & N from the output transformer T1.
3. Locate the four a.c. busbars from the Output Isolator numbered 7(R), 8(S), 9(T) and 10(N) in the Rectifier/Static Switch cabinet and the linking straps connected to them. Take the free end of the linking straps and connect them to the Inverter cabinet a.c. busbars ensuring correct phase connection as illustrated in figure 3-6.
4. Ensure the transformer transportation stabilising bar is removed. Refit the lower protective cover to the Inverter cabinet.
5. Open the upper inner left hand protective door of the inverter cabinet to gain access to the d.c. busbars.
6. Open the doors to the Rectifier/Static Switch cabinet and open the inner upper right hand door to gain access to the d.c. busbars.
7. Using the two angled copper busbar links provided, connect the Rectifier/Static Switch cabinet d.c. busbar to the Inverter Cabinet d.c. busbar as illustrated in figure 3-6.
8. Locate the flat cable assembly FC17 from CN8 on the Inverter Logic board in the Inverter cabinet and secure to the end panel, in the position illustrated in figure 3-6.
9. Locate the flat cable assembly FC17 from CN2 on the UPS Logic board in the Rectifier/Static Switch cabinet and connect to cable assembly FC17 secured above.
10. Locate wires 27, 28, 29, 30, 31, 32, 33, 98 & 99 terminated in connector CN4 and wires 7, 8, 9 & 10 terminated in connector CN5 in the Inverter cabinet and secure the connectors into cabinet end panel in the positions illustrated in figure 3-6.
11. Locate the Rectifier/Static Switch cabinet cable assemblies from the Interface board which terminate in connectors CN4 and CN5 and connect to CN4 and CN5 secured above.
12. Close the inner protective doors and outer doors to both cabinets.

6310018a.02.doc

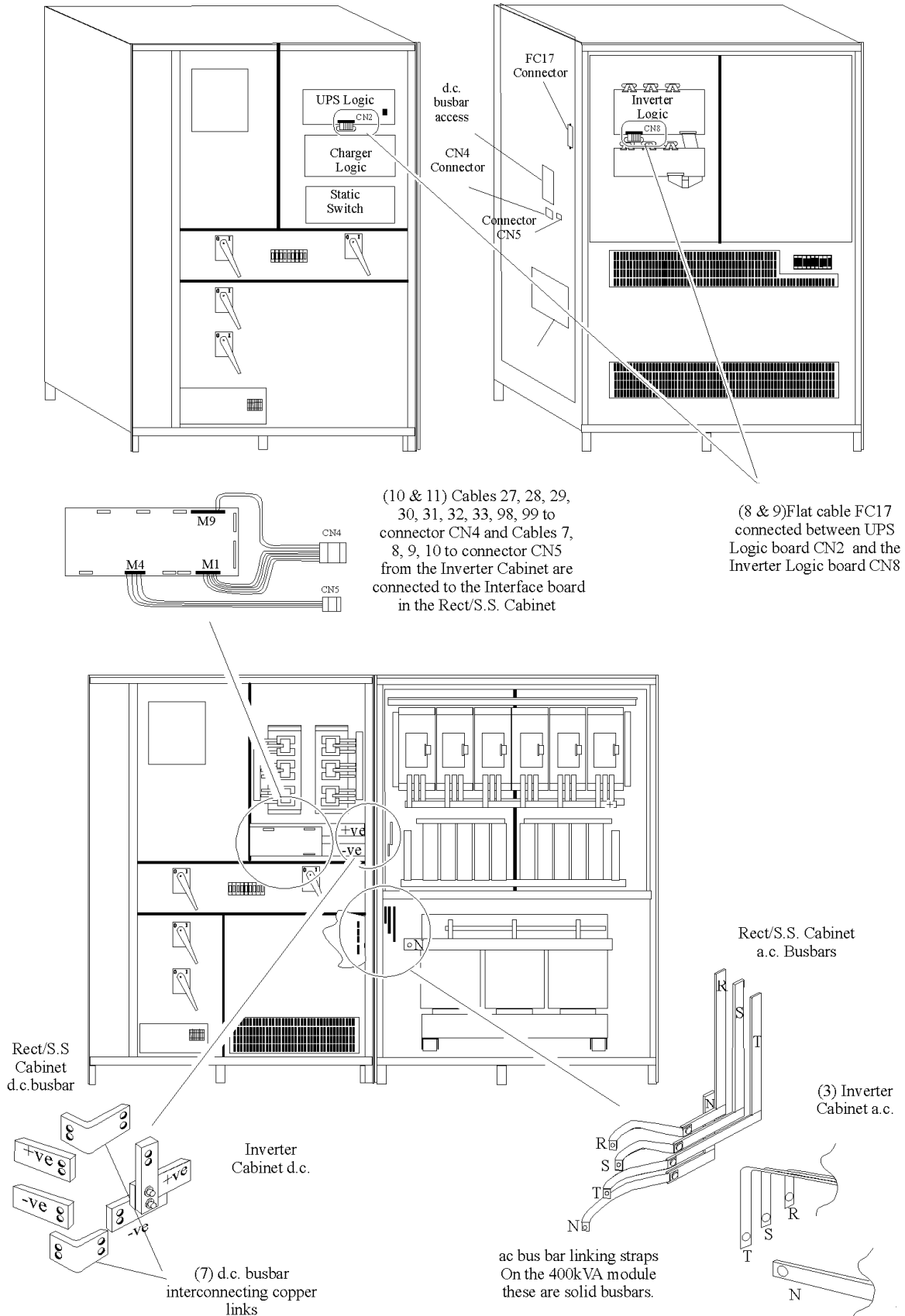

Figure 3-1 . 300/400 kVA model inter-connection cables

### 3.4 Connecting the UPS power cables

#### **WARNING**

*Before cabling-up the UPS, ensure that you are aware of the location and operation of the external isolators that connect the UPS input/bypass supply to the mains distribution panel.  
 Check that these supplies are electrically isolated, and post any necessary warning signs to prevent their inadvertent operation.*

#### 3.4.1 Cable entry

Cables can enter the smaller UPS modules and battery cabinet either from below or through either side. Side entry is made possible by removing blanking pieces fitted in the side ventilation grills to reveal the cable entry holes. This cable entry method allows the equipment to be positioned on a solid floor without the need for cable trenching and also allows cables to pass from one module to the other when positioned side-

by-side.

On units up to 200kVA normal cable entry is from the bottom, however, if top entry is necessary, the optional top entry kit Pt.No. 2174011 V for 80 and 120kVA or Pt. No. 2174033 R for 200kVA is required. On the 300/400kVA unit cable entry is from the bottom or top of the unit.

#### 3.4.2 Cable rating

The maximum current ratings for the power cables are given in table 3-1. The neutral cable (bypass and output) should be sized at up to 1.5 times the phase current to take into account the possible presence of 3rd harmonic currents due to single phase "computer loads".

In a one-plus-one Non-Redundant system, the length of the cables on the Bypass line of the two UPS's should be equal (+/- 20%) to ensure the balance of the currents, when the load is supplied by the mains.

UPS RATING (kVA)	NOMINAL CURRENT (Amps)			CABLE CONNECTION MAXIMUM SIZE		
	Input Mains (with full battery recharge) 380V		Bypass/output 380V	Battery (at low battery disconnect)	Input/output Cable Terminations U - V - W - N	Battery Terminations +ve & -ve
	6 Pulse	12 Pulse				
80	167	158	121	216	Secure with M8 Bolt	M8 Bolt
120	251	237	182	322	Secure with M10 Bolt	M10 Bolt
200	412	390	304	534	Secure with M10 Bolt	M10 Bolt
300	609	579	442	791	Secure with M12 Bolt	M12 Bolt
400	808	769	608	1053	Secure with M12 Bolt	M12 Bolt

*Table 3-1 - Nominal current for power cables*

When sizing battery cables, a maximum volt drop of 3V d.c. is permissible at the current ratings given in table 3-1.

### 3.4.3 Cable connections

Power cables are connected either directly to their respective circuit breakers, or to busbars which are themselves connected to the circuit breakers — see figures 3-8 to 3-12.

**Note:** If the installation includes the use of optional Input Filter Cabinets refer immediately to the Options Chapter, Where these cabinets are fully described. The inclusion of these cabinets in the system affects the method of connecting the UPS power cables given below.

### 3.4.4 Safety earth

The safety earth busbars are located near the input and output power supply connections as shown in the following diagrams. The safety cable must be connected to the earth busbar bonded to each module cabinet.

All cabinets and cable trunking should be earthed in accordance with local regulations.

## **WARNING**

*FAILURE TO FOLLOW ADEQUATE EARTHING PROCEDURES CAN RESULT IN ELECTRIC SHOCK HAZARD TO PERSONNEL, OR THE RISK OF FIRE, SHOULD AN EARTH FAULT OCCUR.*

### 3.4.5 Cabling procedure

#### **Power Cables**

Once the equipment has been finally positioned and secured, connect the power cables as described in the following procedure.

Study the connection diagrams in figures 3-8 to 3-11 and positively identify the diagram relevant to your equipment before commencing cabling.

1. Verify that the UPS equipment is totally isolated from its external power source and all the UPS isolators are open.
2. On each module, connect the **input supply cables** between the mains distribution panel and the UPS input mains terminals. Check that links are fitted between input mains bus bars and bypass supply bus bars (U1 - U3; V1 - V3; W1 - W3).  
— ENSURE CORRECT PHASE ROTATION.

3. If a "split-bypass" configuration is used, connect the UPS **bypass supply cables** between the bypass distribution panel and the UPS bypass supply terminals on each module. Ensure any links fitted between input and bypass bus bars are removed.  
— ENSURE CORRECT PHASE ROTATION.

4. On a Single module connect the UPS **output cables** between the UPS and the load distribution panel.

5. On modules in a **one plus one system** connect the output terminals of both modules together (in parallel).  
— ENSURE CORRECT PHASE-PHASE CONNECTION (U2-U2, V2-V2, W2-W2, N2-N2).

Then connect the UPS **output cables** between the paralleled UPS output terminals and load distribution panel.

*Note:* If the UPS is to be commissioned before the load equipment is ready to receive power then SAFELY isolate the load cables.

6. On each module, connect the **battery cables** between the UPS battery terminals and its associated battery circuit breaker — see figures 3-13 to 3-17. As a safety precaution remove the battery fuse in the module until the arrival of the commissioning engineer.  
— OBSERVE THE BATTERY CABLE POLARITY.

#### **WARNING**

*Do not close the battery circuit breaker before the equipment has been commissioned*

7. Connect the **safety earth** and any necessary bonding earth cables to the copper earth busbar located on the floor of the equipment below the power connections.  
*Note:-* The earthing and neutral bonding arrangement must be in accordance with local and national codes of practice.

#### **Control Cables**

8. Connect the battery **circuit breaker control cables** between the UPS auxiliary terminal block and battery circuit breaker controller board as shown in figures 3-13 to 3-17.

9. If an external **emergency stop facility** is to be used then remove the link between terminals 4 and 5 of the auxiliary terminal block and connect the 'normally closed' remote stop circuit between these two terminals.

*Note:* Terminals 8 and 9 on the auxiliary terminal block are connected to a pair of 'normally closed' contacts on the UPS emergency stop button and will go open circuit when the emergency stop push-button is pressed. These terminals can be used to **control an external circuit breaker** connected in the UPS input mains supply line to isolate the UPS input power when the emergency stop button is pressed.

**One plus one only**

10. On the one-plus-one system only connect the **parallel control ribbon cables** between the Parallel Interface Boards (Part no. 4590049 J) of both modules. Connect one ribbon cable between sockets CN1 on one board and CN2 on the other, and connect the second ribbon cable between the remaining CN1 and CN2 sockets.

**Caution**

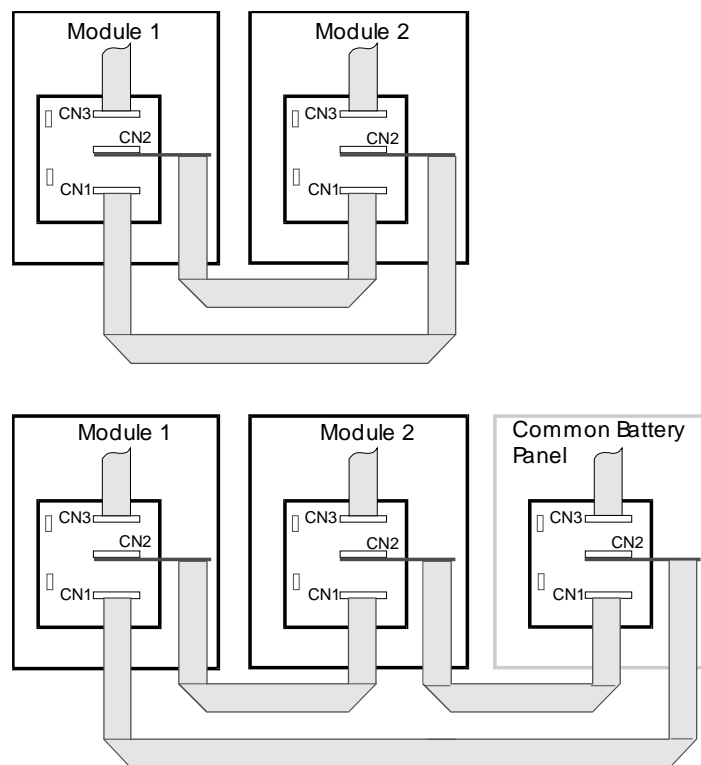
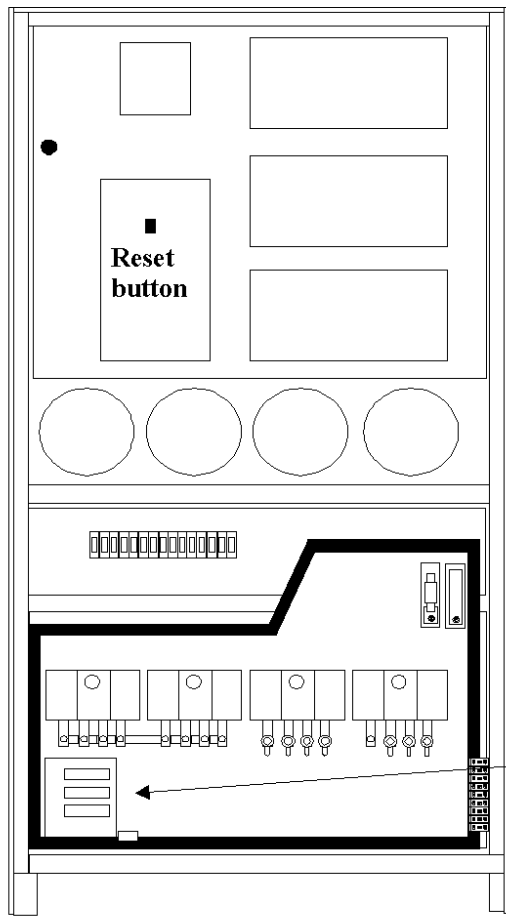

Figure 3-1 . Connecting the parallel interface cables

To maintain EMC compliance all external control and communications cables must be screened.

6310018a.02.doc



**80 KVA Standard**

For SPLIT BYPASS operation ensure the shorting links between bypass and rectifier input bus bars are removed.  
 Connect input supply cables to U1 V1 W1 and Bypass supply cables to U3 V3 W3 N3.

Parallel Interface Board  
 (1+1 only)

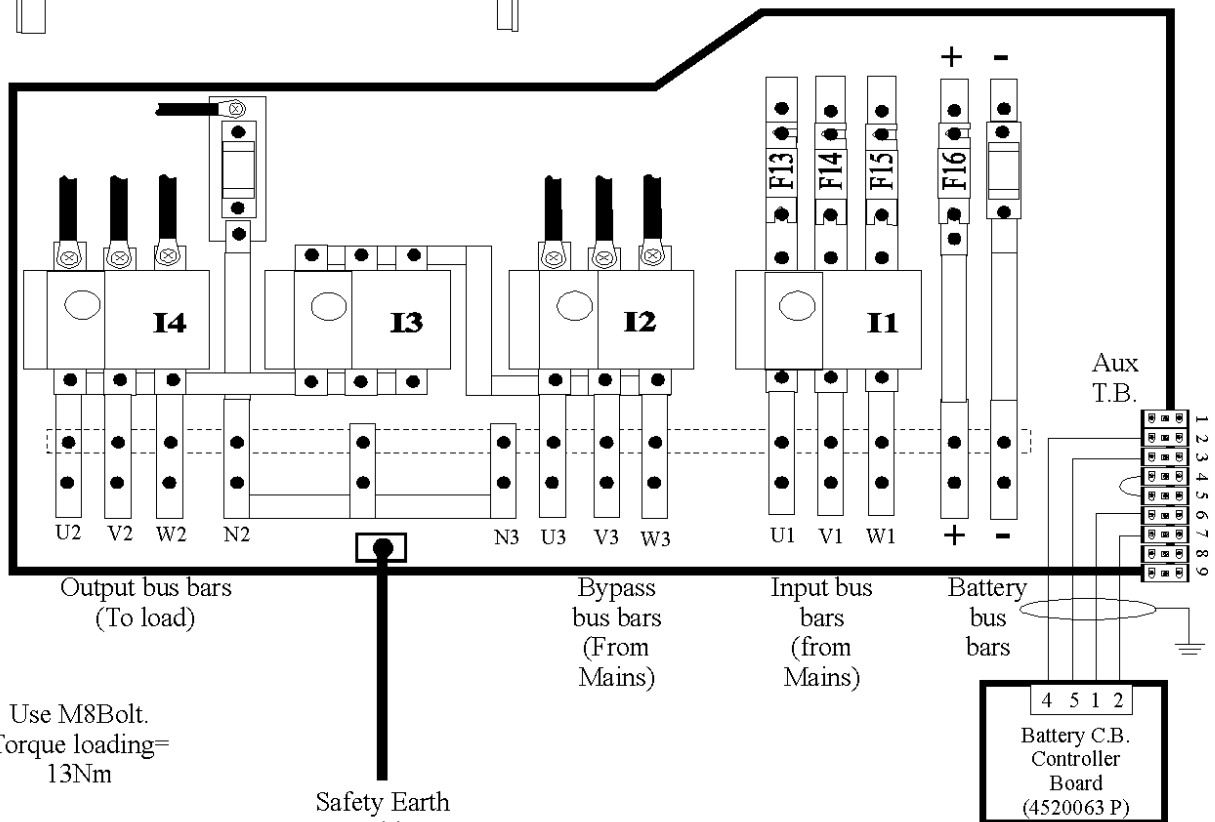
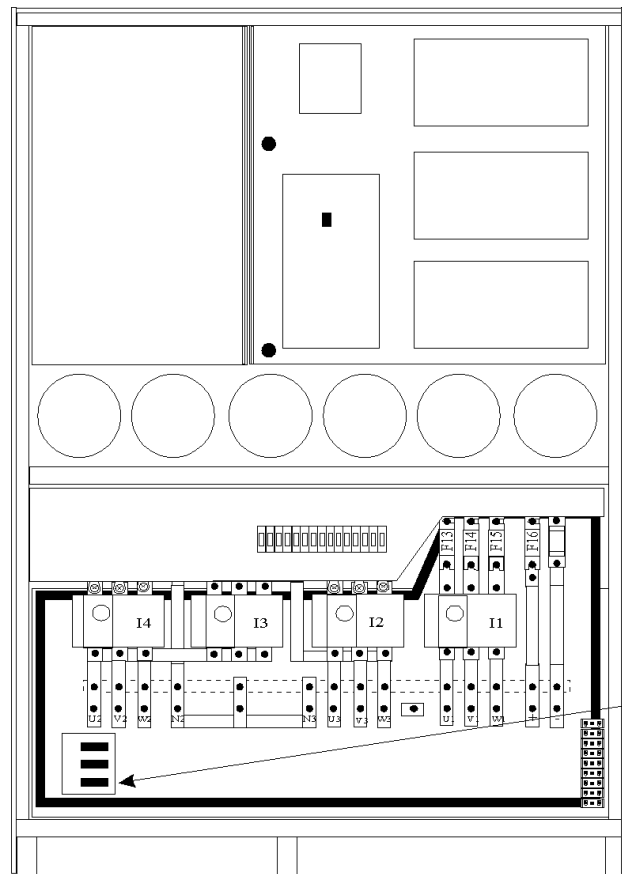

Figure 3-2 . Cable connections for standard 80kVA



**120 KVA Standard**

For SPLIT BYPASS operation ensure the shorting links between bypass and rectifier input bus bars are removed.  
 Connect input supply cables to U1 V1 W1 and  
 Bypass supply cables to U3 V3 W3

Parallel Interface Board (1+1 only)

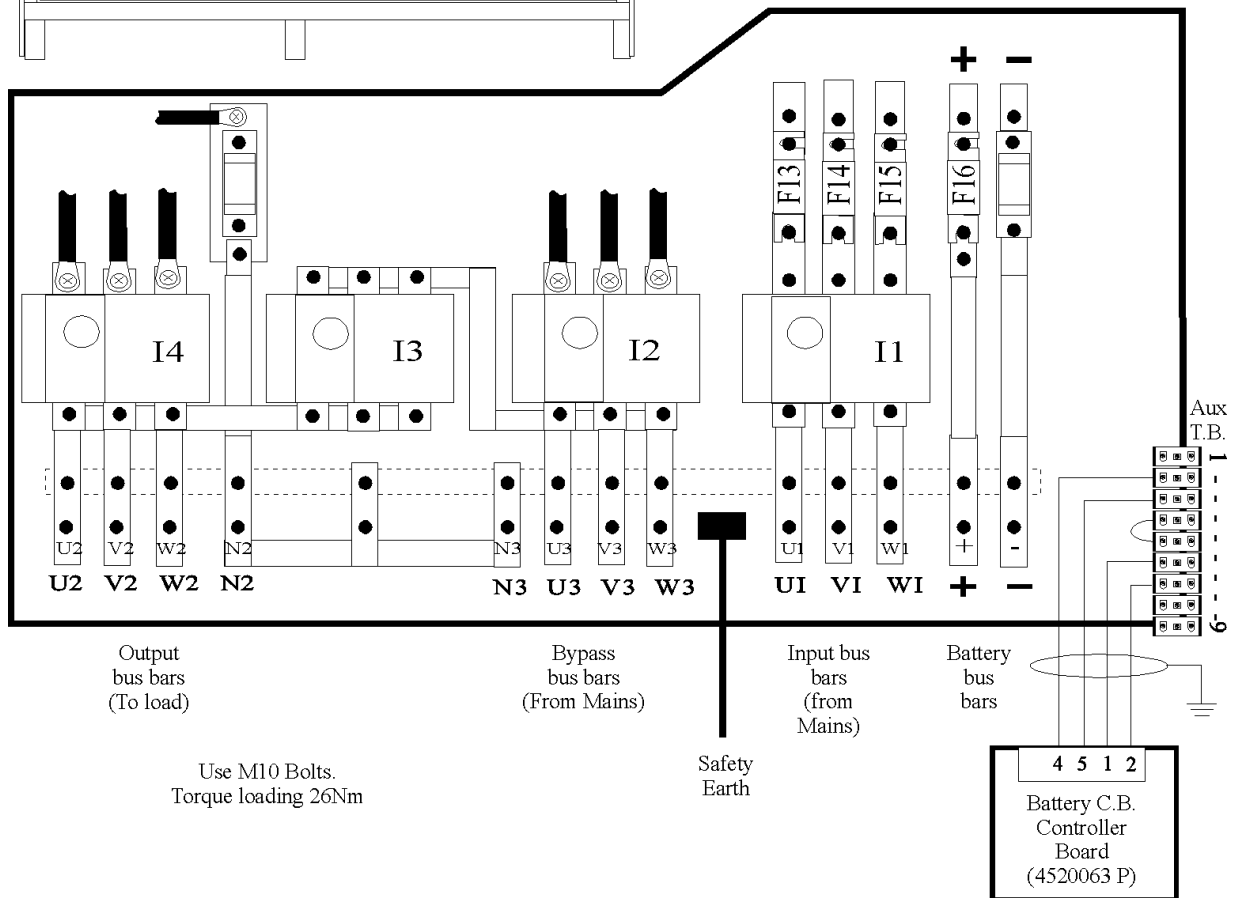

Figure 3-3 . Cable connections for standard 120kVA

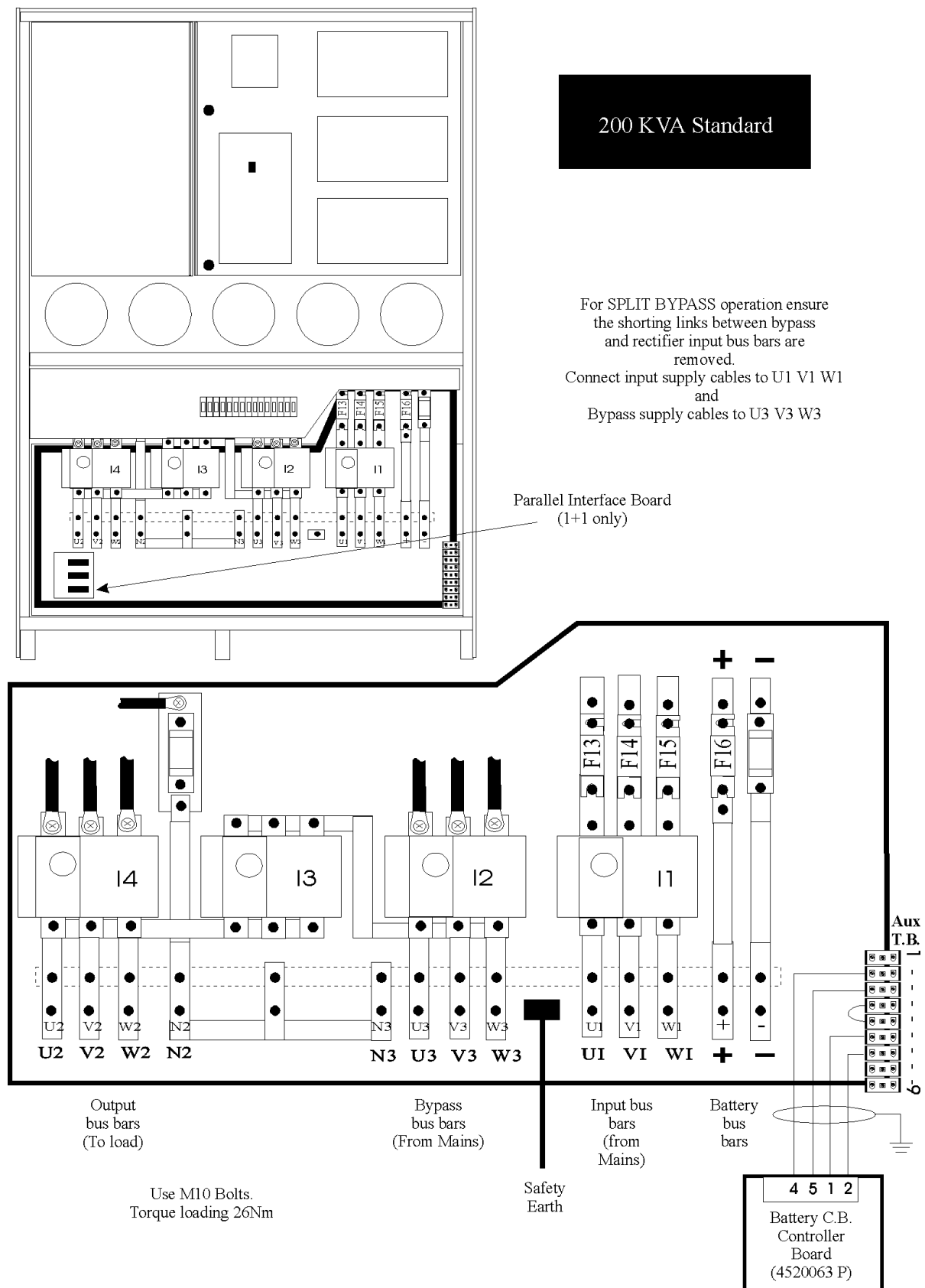

Figure 3-4 . Cable connections for standard 200kVA

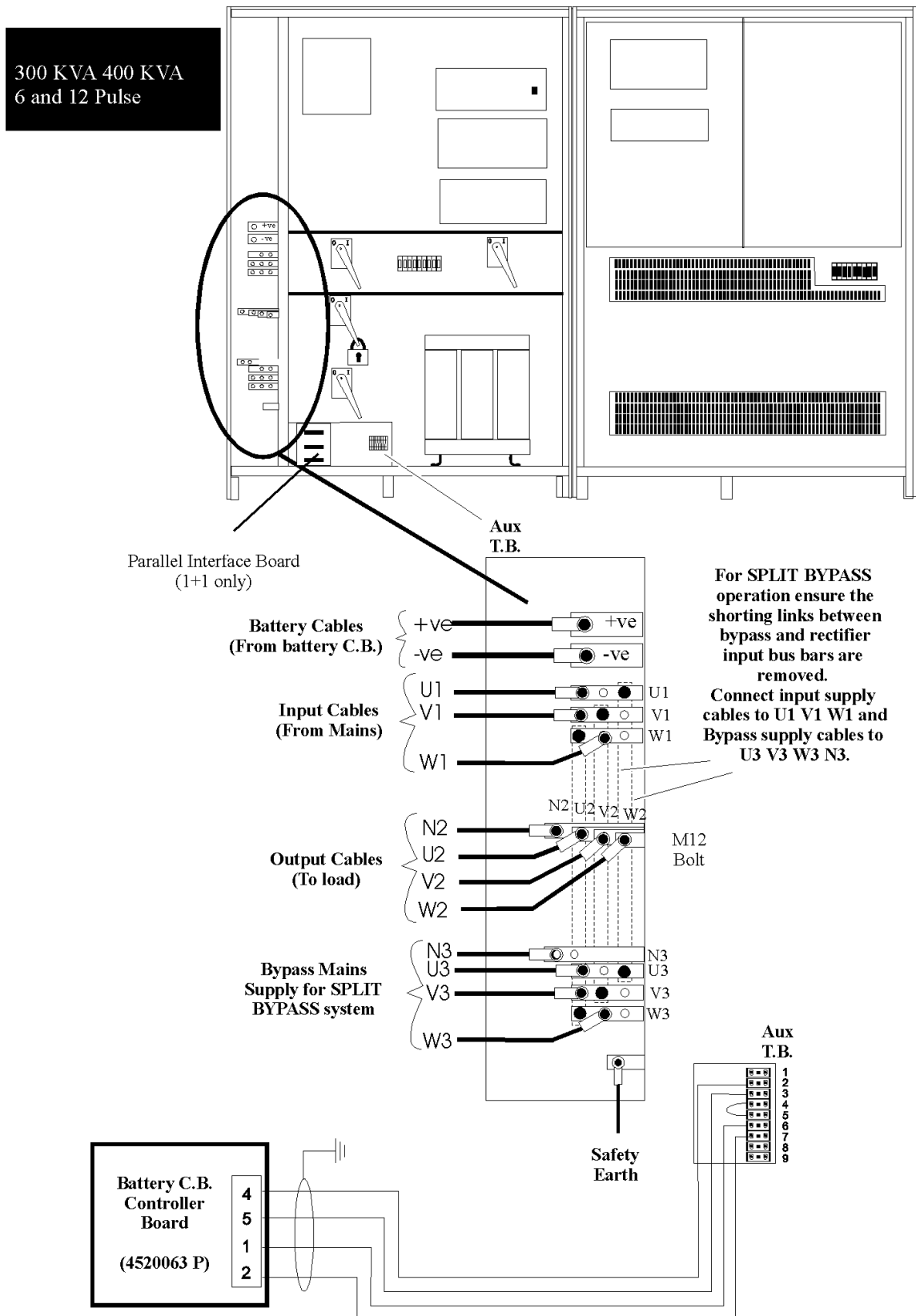

Figure 3-5 . Cable connections for 6 & 12 Pulse 300/400 kVA modules

### 3.5 Battery Installation

#### **WARNING**

*Only qualified personnel should install or service batteries.  
A battery can present a risk of electric shock or burn from high short circuit currents.  
Eye protection should be worn to prevent injury from accidental electrical arcs.  
Remove rings, watches and all metal objects.  
Only use tools with insulated handles.  
Wear rubber gloves.  
If a battery leaks electrolyte, or is otherwise physically damaged, it should be placed in a container resistant to sulphuric acid and disposed of in accordance with local regulations.  
If electrolyte comes into contact with the skin the affected area should be washed immediately.  
Batteries must be disposed of according to local environmental laws.*

Due to the inverter design the d.c. bus bar voltage level is dependent on the system output a.c. voltage. Therefore, the number of battery blocks required will differ according to the system requirements, as shown below:

380V a.c. system requires 432V d.c. bus bar = 32 battery blocks / 12 V (192 cells).

400V a.c. system requires 446V d.c. bus bar = 33 battery blocks / 12 V (198 cells).

415V a.c. system requires 459V d.c. bus bar = 34 battery blocks / 12 V (204 cells).

The batteries associated with the 80 kVA and 120 kVA UPS can be contained in a purpose-built battery cabinet ( part number 5320024I {860mm wide, 250 A circuit breaker}) which sits along side the main UPS equipment. Sealed, maintenance-free batteries are normally used in this type of installation.

Where battery racks are used, they should be sited and assembled in accordance with the battery manufacturer's recommendations. In general, batteries require a well ventilated, clean and dry environment at reasonable temperatures to obtain efficient battery operation.

Battery manufacturers' literature provides detailed safety measures to be observed when employing large battery banks and these should be studied and the proposed battery installation checked to verify compliance with the appropriate recommendations.

In general a minimum space of 10 mm must be left on all vertical sides of the battery block. A minimum clearance of 20 mm should be allowed between the cell surface and any walls. A clearance of 150 mm should be allowed between the top of the cells and the underside of the shelf above (this is necessary to for monitoring and servicing the cells). All metal racks and cabinets must be earthed. All live cell connections must be shrouded.

The batteries are connected to the UPS through a circuit breaker which is manually closed and electronically tripped via the UPS control circuitry. If the batteries are cabinet-mounted this circuit breaker is fitted within the cabinet; however, if the batteries are rack-mounted or otherwise located remote to the main UPS cabinet then the battery circuit breaker must be mounted as near as possible to the batteries themselves, and the power and control cables connected to the UPS using the most direct route possible. Liebert offer a purpose designed remote battery circuit breaker box, containing the circuit breaker and its necessary control board, as a standard option kit. The battery cabinet or circuit breaker box must be bonded to the UPS cabinet.

### 3.5.1 860 mm cabinet (250 Amp circuit breaker)

The 860 mm cabinet with a 250 Amp circuit breaker and extension cabinets are designed for use with the Series 7400 80-120 kVA UPS.

The 860mm battery battery cabinet autonomy time can be extended by attaching a 320mm wide extension cabinet part N°5320025J to the main cabinet.

All cabinets are secured and bonded together using the bolts supplied and the holes proved in the cabinet side struts.

A typical battery layout for a single cabinet is shown in figure 3-13, this can be extended by using extension cabinets attached to the basic unit. Each extension cabinet is supplied without side covers, as the covers from the basic unit are then used. This side access allows batteries to be positioned from either the front or side.

As many different battery combinations can be used only the connections for the basic unit have been shown in figure 3-13, additional battery strings can be added and would be connected in parallel.

The battery cabinets are designed to hold between 32 and 34 batteries on 4 levels, free standing on adjustable rails. Nine batteries can be fitted to the 3 upper levels with up to seven batteries on the lower level. The rails are adjustable giving a maximum battery width of 176mm and a maximum depth of 270mm, this allows batteries to be positioned as shown or turned through 90°. The rails can also be removed or re-positioned to accommodate batteries of different sizes.

Figure 3-14 shows an alternative arrangement to that above. In this example larger capacity batteries are used. As can be seen, the rails have been adjusted and removed to accommodate the larger battery of which only sixteen can be fitted within the cabinet. The other sixteen batteries (needed to maintain a 432 V d.c. bus bar) are arranged within an extended battery cabinet and connected in series to the main cabinet batteries. Further pairs of extended battery cabinets can be added in parallel.

The basic cabinet is supplied with the battery circuit breaker and interface board. Connection to the UPS is shown in figure 3-13.

Due to the flexibility of the type and size of cells that can be used in this installation it would be impracticable to provide specific installation instructions. However as a general guide:-

Always install the batteries starting from the bottom and work upwards.

Leave the end links marked (B) see figure 3-13 until the last connection on each level.

After each connection is made fit the insulation shroud for that terminal into position.

As an added safety precaution we suggest that link (A) see figure 3-13 is left disconnected until all batteries are fitted. Once all the batteries are fitted connect link (A).

Please refer to the battery manufacturers instructions and the drawings supplied with the module for safety and specific installation instructions.

6310018a.02.doc

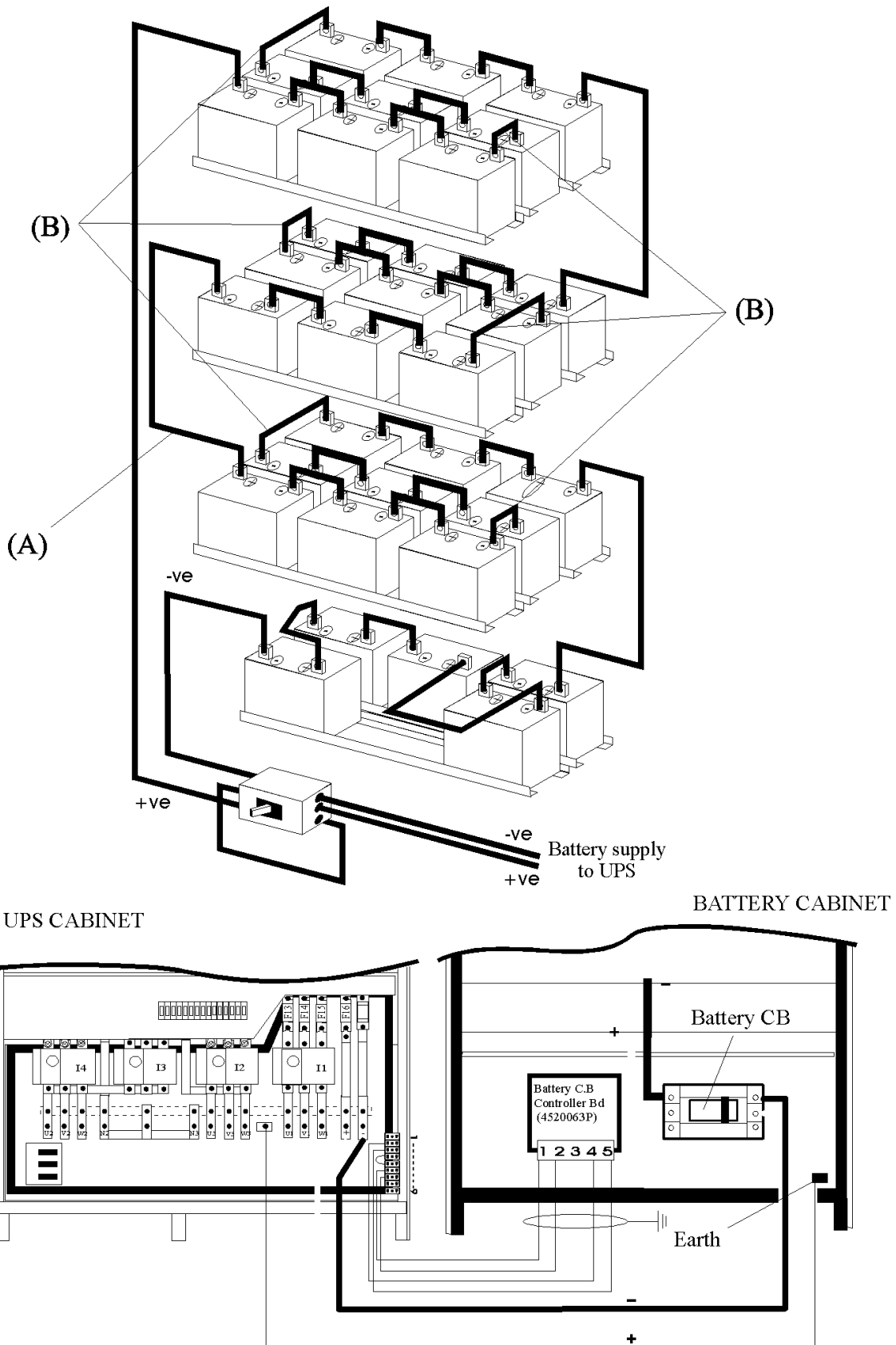

Figure 3-1 . 860mm Battery cabinet Typical battery layout and connection detail

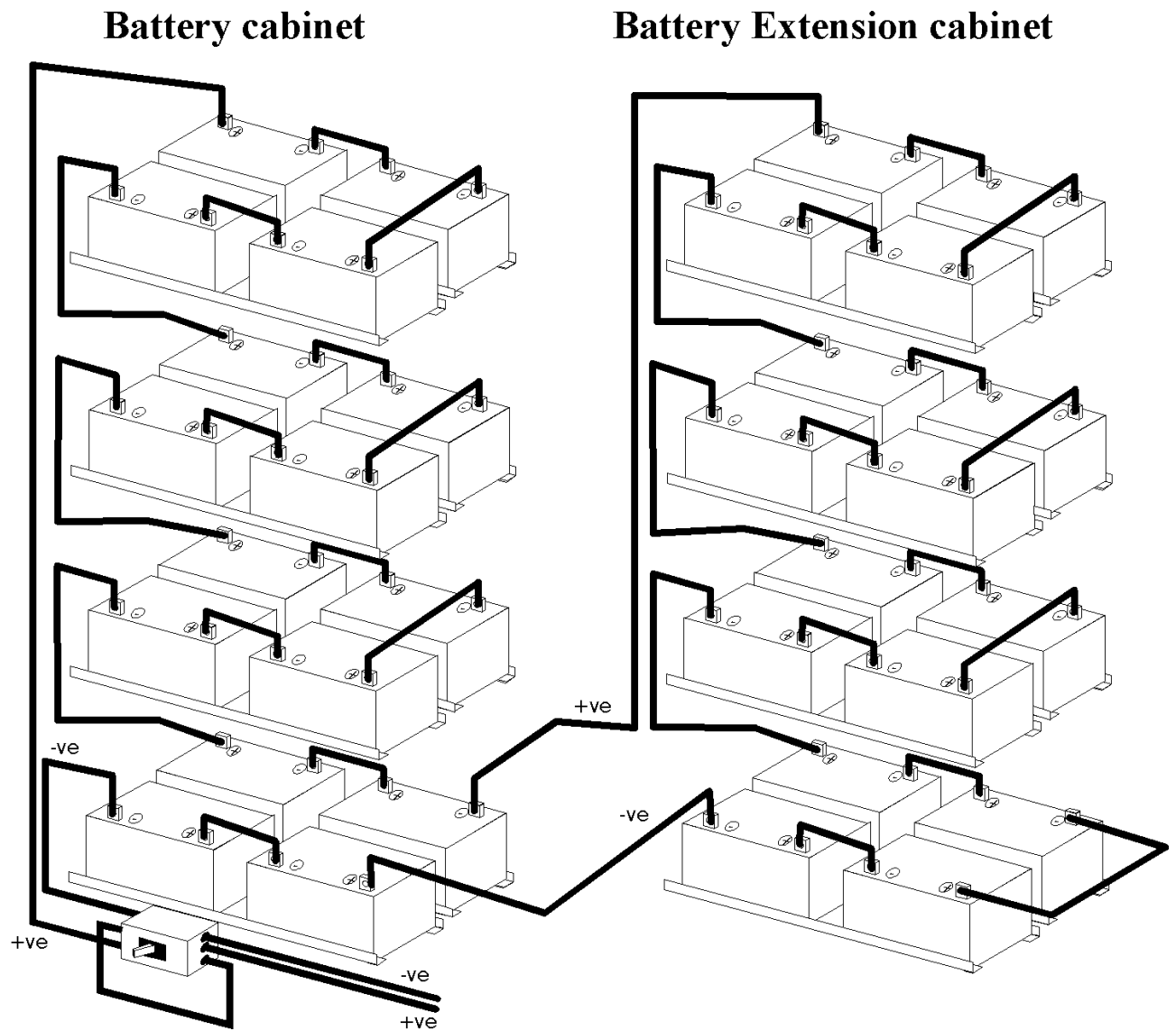

Figure 3-2 . Typical example of battery cabinet with extension cabinet

**3.5.2 Battery circuit breaker boxes**

A battery circuit breaker box houses the battery circuit breaker and its controller board and is used to connect the battery to the UPS in installations where the batteries are not contained in the standard battery cabinet.

Several 'boxes', of various current ratings, are available and are similar in their design and content. These are listed below:

- 250 Amp C/B Part No4641007H for use with 80 kVA models.
- 400 Amp C/B Part No4641008I for use with 120 kVA model.
- 630 Amp C/B Part No4641009D for use with 200 kVA model.
- 800 Amp C/B Part No4641011L for use with 300 kVA model.
- 1000 Amp C/B Part No4641012M for use with 400 kVA model.

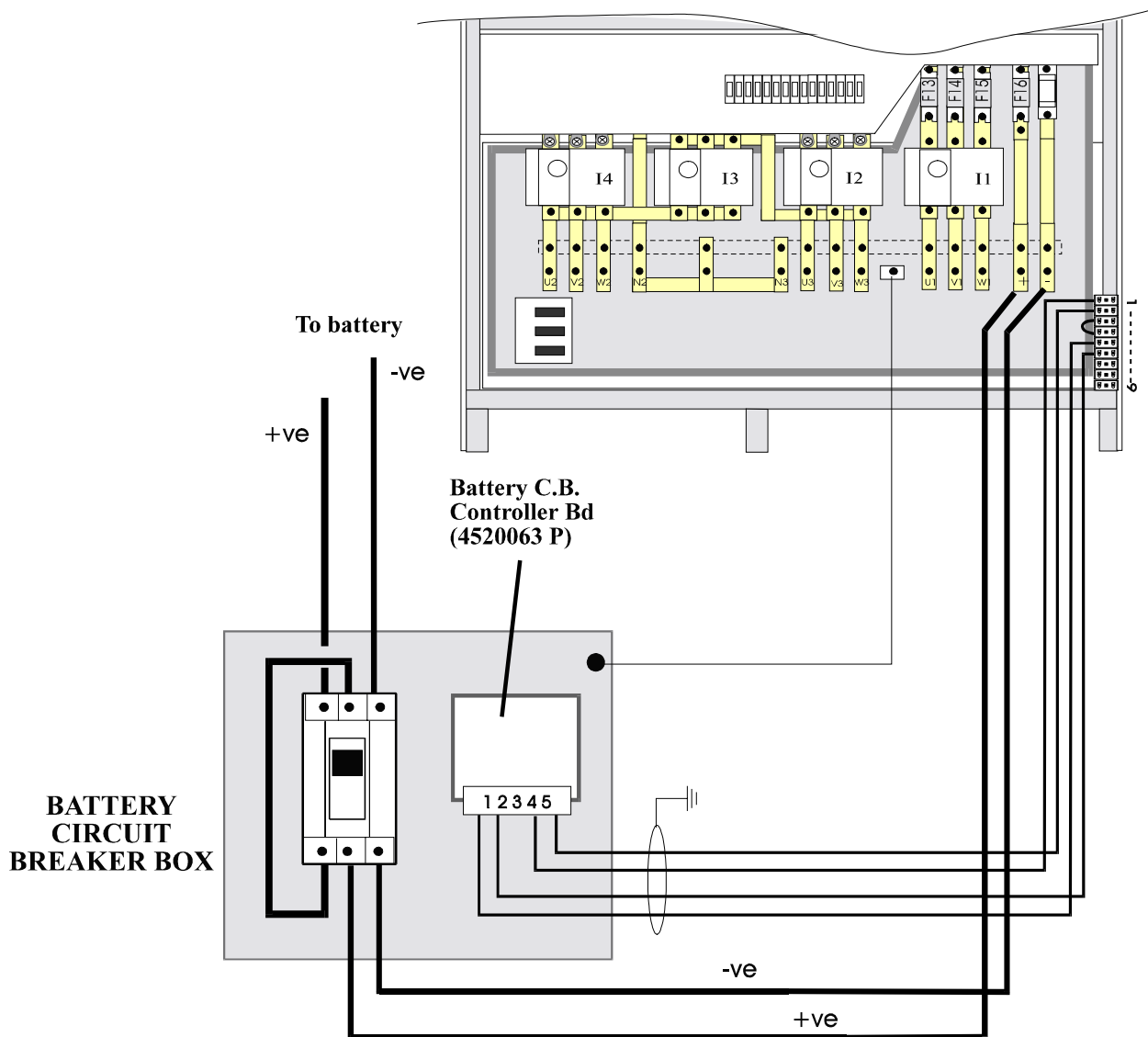

Figure 3-1 . Battery C/B box connections 80-120 kVA UPS

Usually the 'box' is fitted as close as possible to the batteries.  
 Figures 3-15 to 3-17 show details of the power and control cable connections between the circuit breaker box and the UPS itself. These are similar to the connections made to the battery cabinet previously described.

As a safety precaution, remove the battery fuse in the UPS before making the battery circuit breaker power connections.

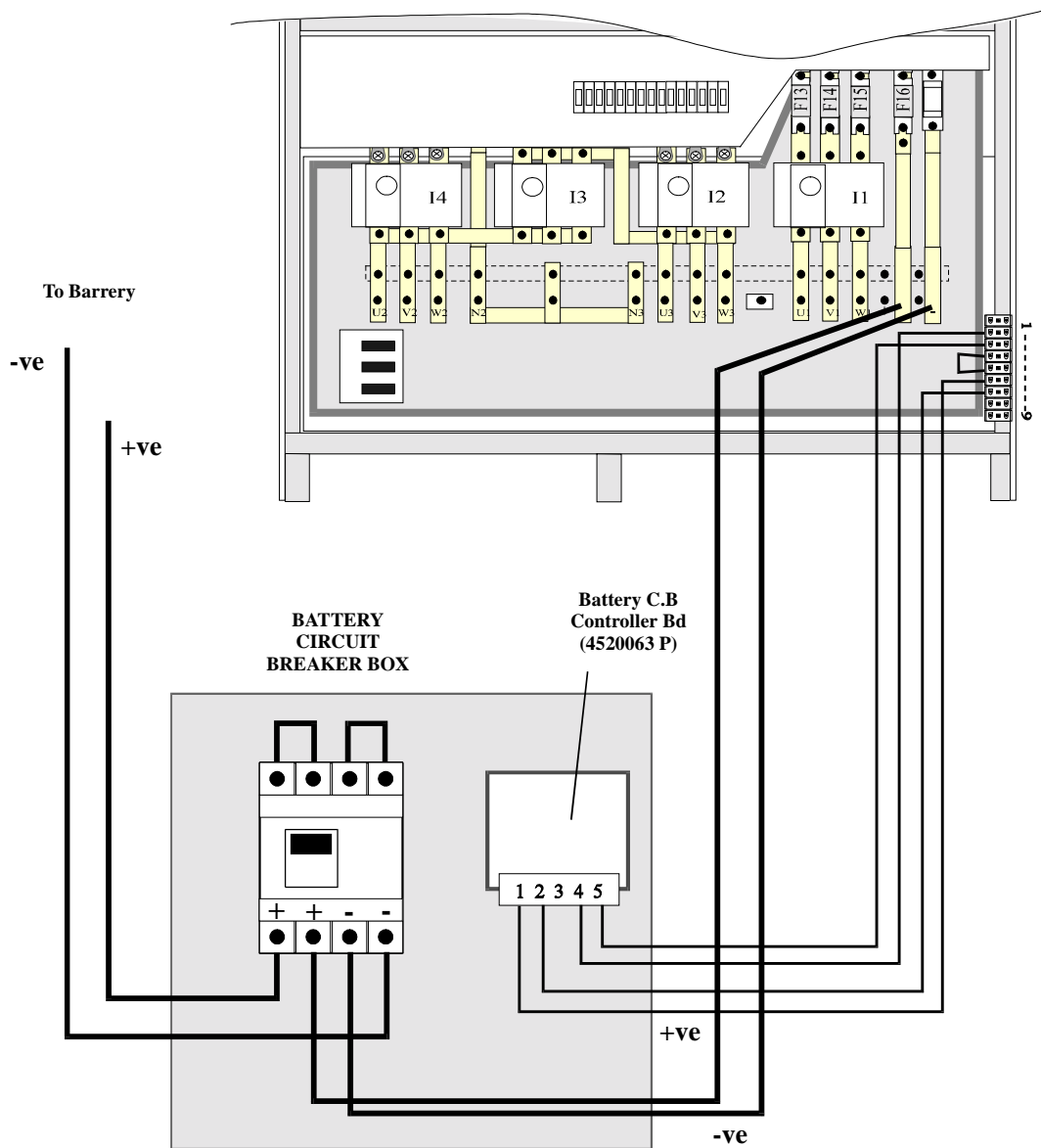

Figure 3-2 . Battery C/B box connections 200 kVA UPS

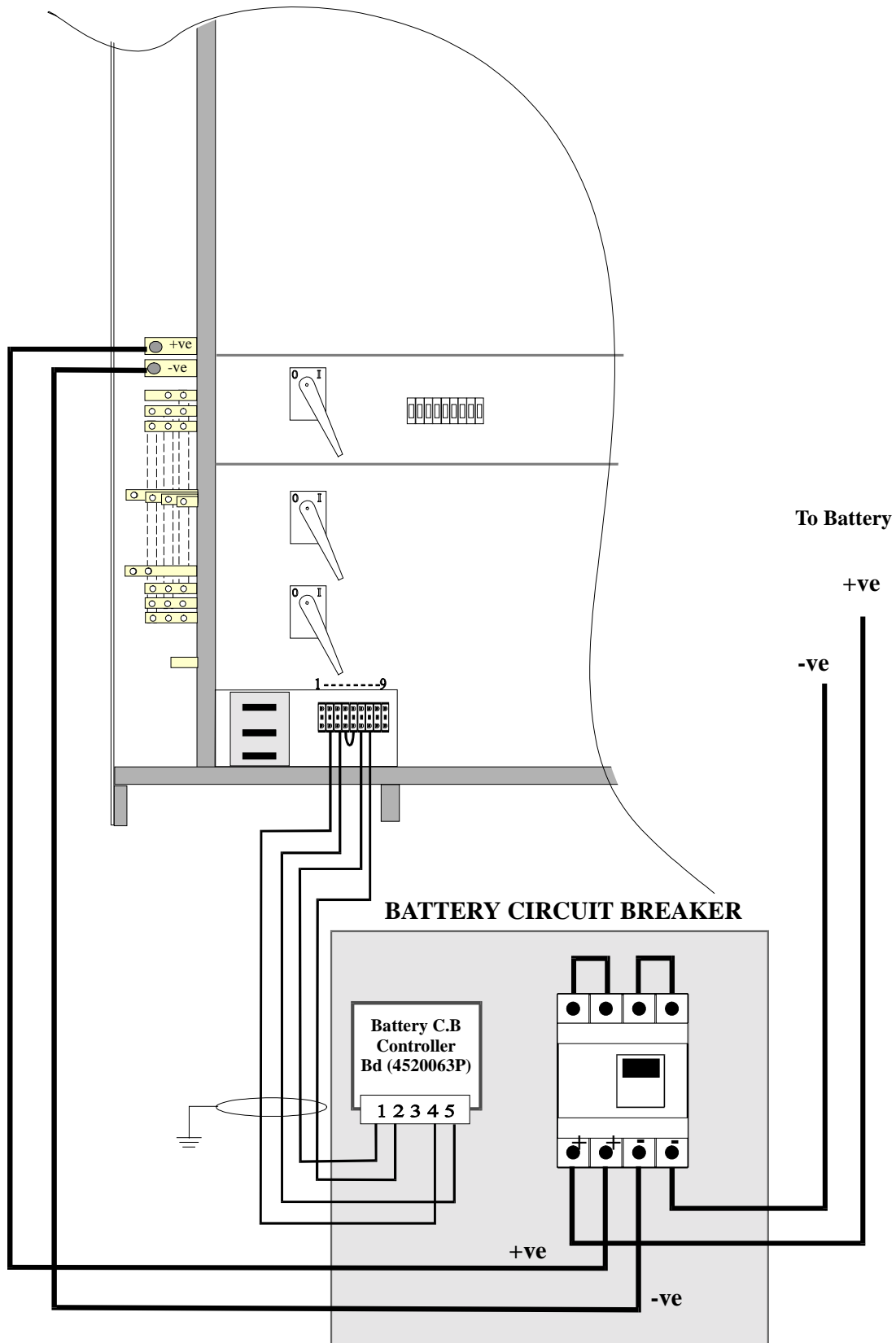

Figure 3-3 . Battery C/B box connections for 300kVA and 400 kVA Modules

### 3.5.3 Battery Display Initialisation

On initial installation or on change of the battery, it is necessary to enter the battery nominal capacity data into the system. This allows the front panel to display the battery state either as a percentage of charge with the input a.c. power supply present or as the time remaining on battery with the a.c. power supply absent. The battery circuit breaker must be closed during this procedure.

To initialise the system and insert the nominal battery capacity, press push button 'B' then carry out the following procedure:

1. On the PCB 4550001 B move the link on SH7 to position on pins 2-3.
2. On the display panel press push buttons 'f', 'B' and ((\*)).
3. Check the display reads:

***'PHASE CALIBRATION' FREQUENCY: XX,X***

4. Press the ((\*)) push-button twice and the display will show:-

***BATTERY (AH) = NEW VALUE***

5. Using the keys: Vo(forward 1), I (forward 10), f (back 1) and B (back 10), insert the nominal value for the capacity of the installed battery, when completed press the ((\*)) key again.
6. Repeat step 3 and check that the new value for the battery capacity is displayed.

***BATTERY (AH) = (new inserted value)***

7. On conclusion of the above procedure reposition the link on SH7 to pins 1-2.
8. On the display panel press the keys 'f', 'B' and ((\*)).
9. The display should revert to the default screen

***UPS BIOS VERSION 2.1 1-7-1995***

**The unit has now been restored to normal.**

**Note:** It is necessary to ensure that the reading on the display panel shows B = 100% both on initial installation and on change of battery. This is to ensure that the measurement reading and subsequent readings are correct.

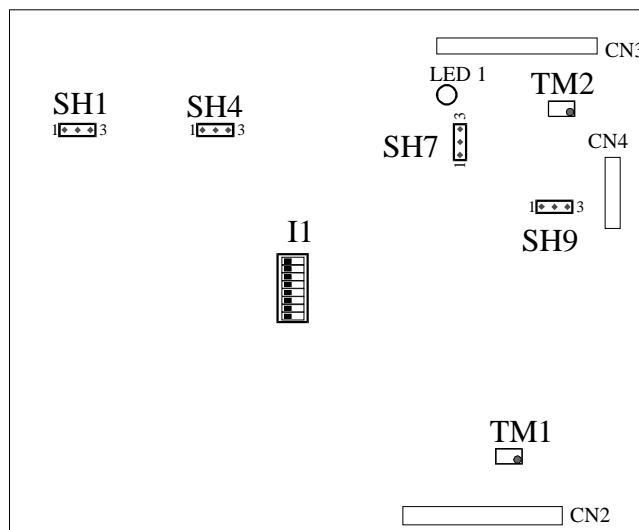

Figure 3-1 . SH7 location on Microprocessor PCB



---

## 4. Chapter 4 - Optional equipment

---

Several items of optional equipment are available for fitting to the 7400 series UPS for use by the customer as required.

These options are:

- IBM AS400 Interface (part no. 4590041 B).
- IBM AS400 Interface with 4-way output (part no. 4590045F).
- External Interface Board (part no. 4590044E).
- Remote Alarms Monitor (part no. 4305001Z).
- Remote alarms and control panel (part no. 4305002A).
- RS232 communications interface (SGC) (part no. 4550002C).
- 5th Harmonic Input filter Option.
- Cable top entry kit for 80 and 120 kVA (part no. 2174011V).
- Cable top entry kit for 200 kVA (part no. 2174033 R).
- 12 Pulse system option (80,120 and 200 kVA).
- Option Kit (includes Batt. Temp. compensation; Input current limit; Batt. Current limit) (part no. 77000005).

---

## 4.1 AS400 Interface Board (4590041B)

---

The AS400 Interface board connects the five most operationally critical UPS alarms to an IBM AS400 computer, which is designed to monitor such alarms and respond to their appearance.

The alarms in question are:

- Mains failure
- Load on inverter
- Low battery and/or battery circuit breaker open
- Load on mains (bypass)
- Load on maintenance bypass

These alarm signals are provided by volt-free relay contacts.

The AS400 Interface Board is fitted to the bottom of the UPS cabinet door and connected to the UPS control electronics by a ribbon cable (FC13 in the 80/120/200 kVA models and FC19 in the 300 - 400kVA models ) which is fitted to all modules and normally stowed in the cable loom when this option is not used.

### 4.1.1 AS400 Interface Board outputs

Two female D-type connectors are provided on the Interface Board to enable the above signals to be connected to the AS400 computer. One connector, CN1, has 9 pins and the other, CN2, has 15. Figure 4-1 provides pin-out details for these connectors.

*Note:* Use one connector only -i.e. don't use both connectors simultaneously.

In addition to the D-type connectors, the AS400 Interface Board also contains a number of volt-free relays whose contacts provide a duplicate set of volt-free alarm outputs that are connected to terminal block M1 as shown in figure 4-1. These outputs can be used to drive an external alarms monitoring device. Maximum contact rating on M1 terminals = 50 Vcc @ 1 Amp.

*Note:* When using the above contacts for remote alarm annunciation, the power supply for the remote indicators must be provided from an external power source. Under no circumstances should the UPS internal low voltage supplies be used for this purpose.

### 4.1.2 Remote control inputs

The Interface Board has facilities to accept two remote control inputs, as shown in figure 4-1. One remote input allows the inverter to be shut down (transferring the load to the bypass supply) and the other enables the inverter synchronisation feature to be inhibited. The inverter synchronisation inhibit feature is most often used if the UPS is powered from a standby generator when the input mains supply fails and the generator frequency is unstable.

The external control signals (12V dc or ac) should be connected to terminal block M2 as shown in figure 4-1. Once again, the voltage applied to these terminals must be generated by an external power source and not taken from the UPS internal low voltage supplies.

### 4.1.3 Calibration

When fitting the AS400 interface board to the 7400 series, ensure that link SH-1 is in position 1-2.

### CONTROL INPUTS

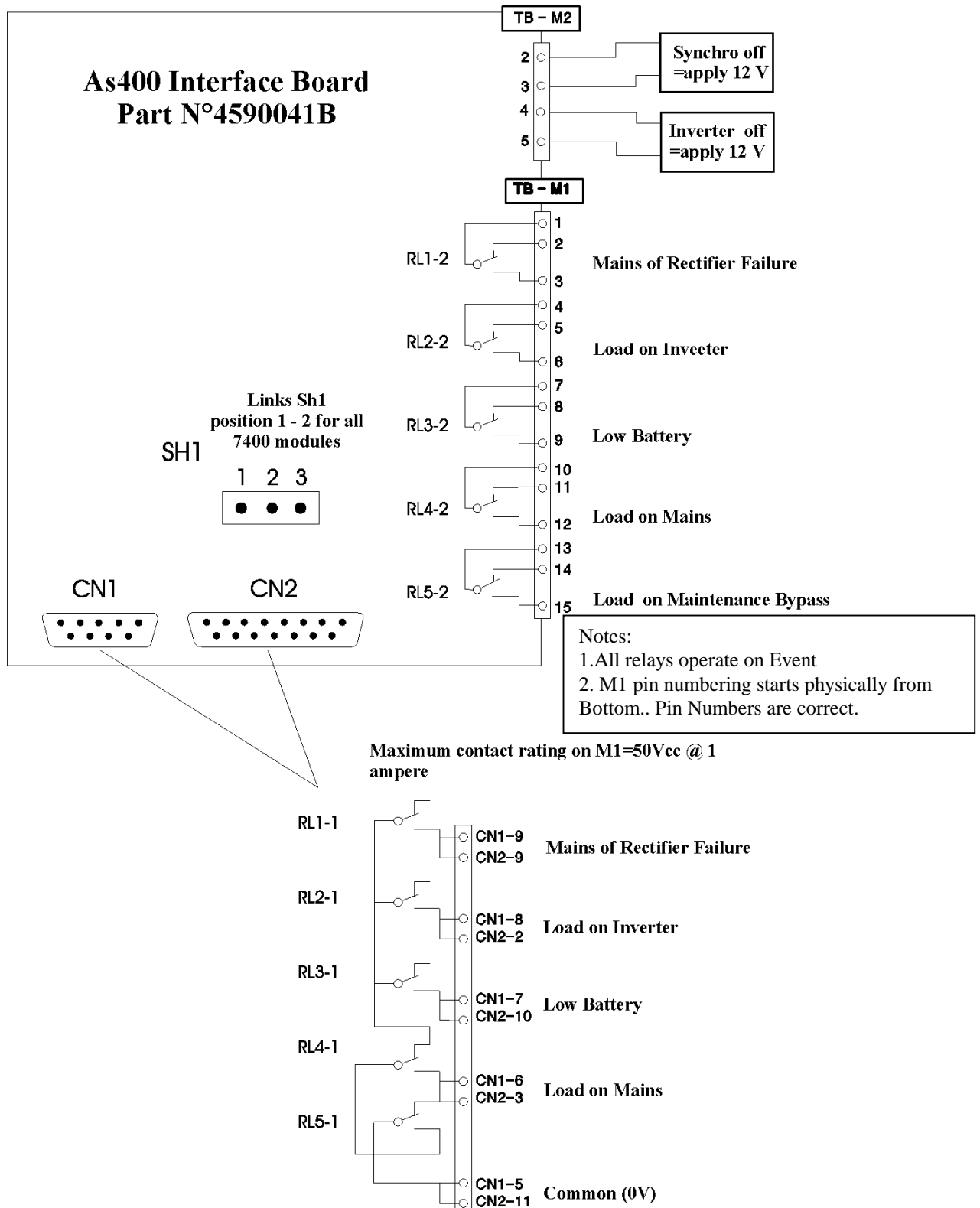

Figure 4-1 . AS400 Interface Board outputs Single and 1+1 Modules

---

## 4.2 4-Way AS400 Interface Board (4590045F)

---

The 4-way AS400 Interface board connects five critical UPS alarms to four output terminal blocks M1 - M4 as shown in figure 4-2. These alarm signals can be connected to a IBM AS400 computer designed to monitor such alarms, or to a Remote Alarm Monitor panel.

The alarms monitored are:

- Mains failure
- Load on inverter
- Low battery and/or battery circuit breaker open
- Load on mains (bypass)
- Load on maintenance bypass

The signals commonly interfaced with the AS400 are:

- Mains failure
- Load on inverter or UPS ON
- Low battery .

These alarm signals are provided by volt-free relay contacts (maximum rating 50V @ 1 Amp).

*Note:* When using the above contacts for remote alarm annunciation, the power supply for the remote indicators must be provided from an external power source. Under no circumstances should the UPS internal low voltage supplies be used for this purpose.

The 4-way AS400 Interface Board is also positioned in the UPS cabinet (below the power isolators), and connected to the UPS control electronics by a ribbon cable (FC13 in 80-120 and 200 kVA modules and FC19 in 300-400 kVA modules) connected to CN1.

### 4.2.1 Remote control inputs

The Interface Board has facilities to accept two remote control inputs, as shown in figure 4-2. One remote input allows the inverter to be shut down (transferring the load to the bypass supply) and the other enables the inverter synchronisation feature to be inhibited. The inverter synchronisation inhibit feature is most often used if the UPS is powered from a standby generator when the input mains supply fails and the generator frequency is unstable.

The external control signals (12V dc or ac) should be connected to terminal block M1 as shown in figure 4-2. Once again, the voltage applied to these terminals must be generated by an external power source and not taken from the UPS internal low voltage supplies.

### 4.2.2 Calibration

When fitting the AS400 interface board to the 7400 series, ensure that link SH-1 is in position 1-2.

6310018a.02.doc

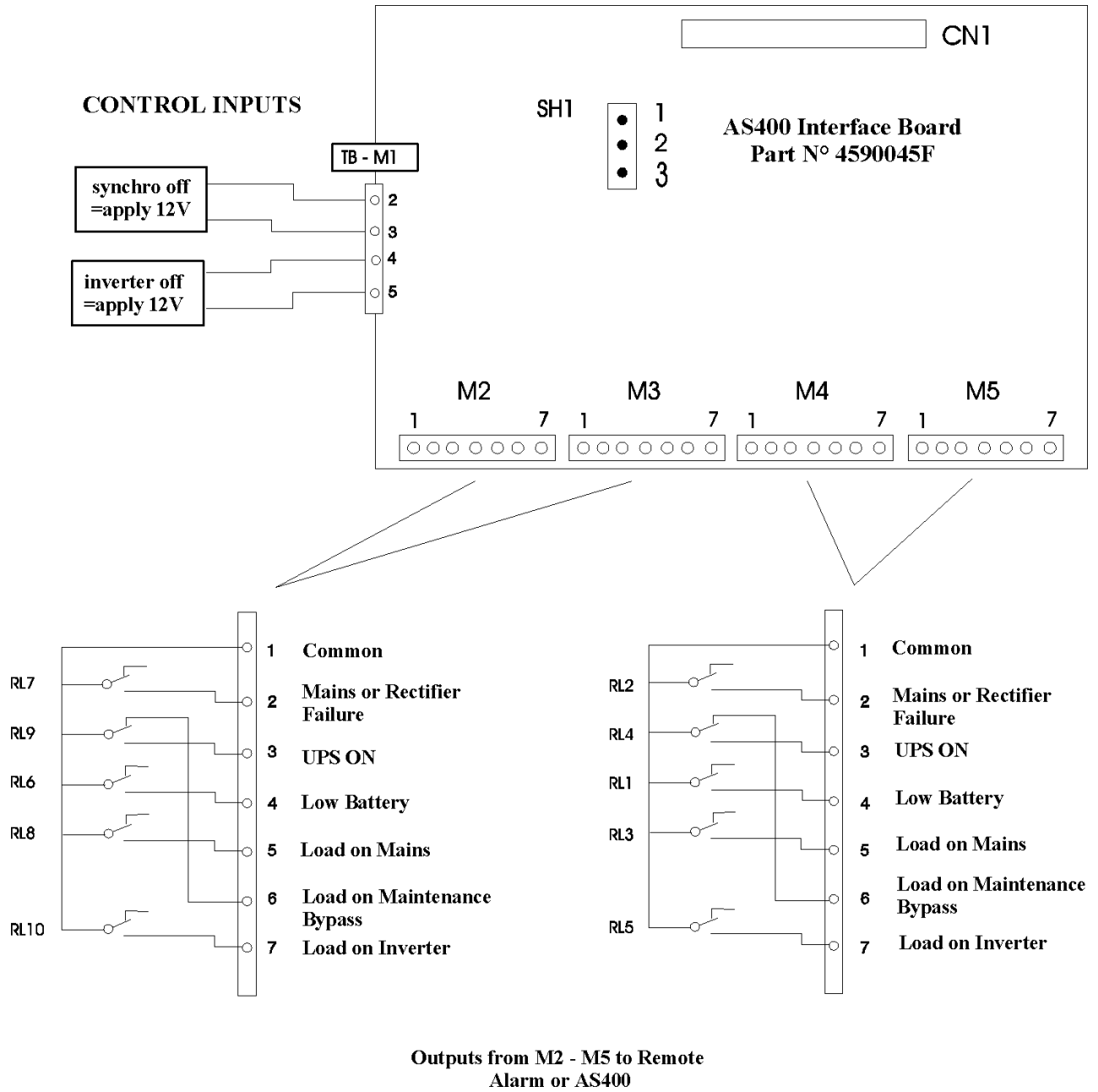

Figure 4-1 . Four output AS400 interface board

---

### 4.3 Output Interface (Remote Alarms) Boards (4590044E)

---

#### 4.3.1 Alarm outputs

One remote alarm board, shown in figure 4-3, enables the alarm signals generated within the UPS to be connected by means of volt-free change-over relay contacts to a remote monitoring device. The board can be fitted on the bottom of the UPS cabinet door, together with the AS400 Interface Board.

*Note:* When using the contacts for remote alarm annunciation, the power supply for the remote indicators must be provided from an external power source. Under no circumstances should the UPS internal low voltage supplies be used for this purpose.

#### 4.3.2 Remote control inputs

The board has facilities to accept two remote control inputs, as shown in figure 4-3. One remote input allows the inverter to be shut down (transferring the load to the bypass supply) and the other enables the inverter synchronisation feature to be inhibited. The inverter synchronisation inhibit feature is most often used if the UPS is powered from a standby generator when the input mains supply fails and the generator frequency is unstable.

The external control signals (12V dc or ac) should be connected to terminal block M2 as shown. Once again, the voltage applied to these terminals must be generated by an external power source and not taken from the UPS internal low voltage supplies.

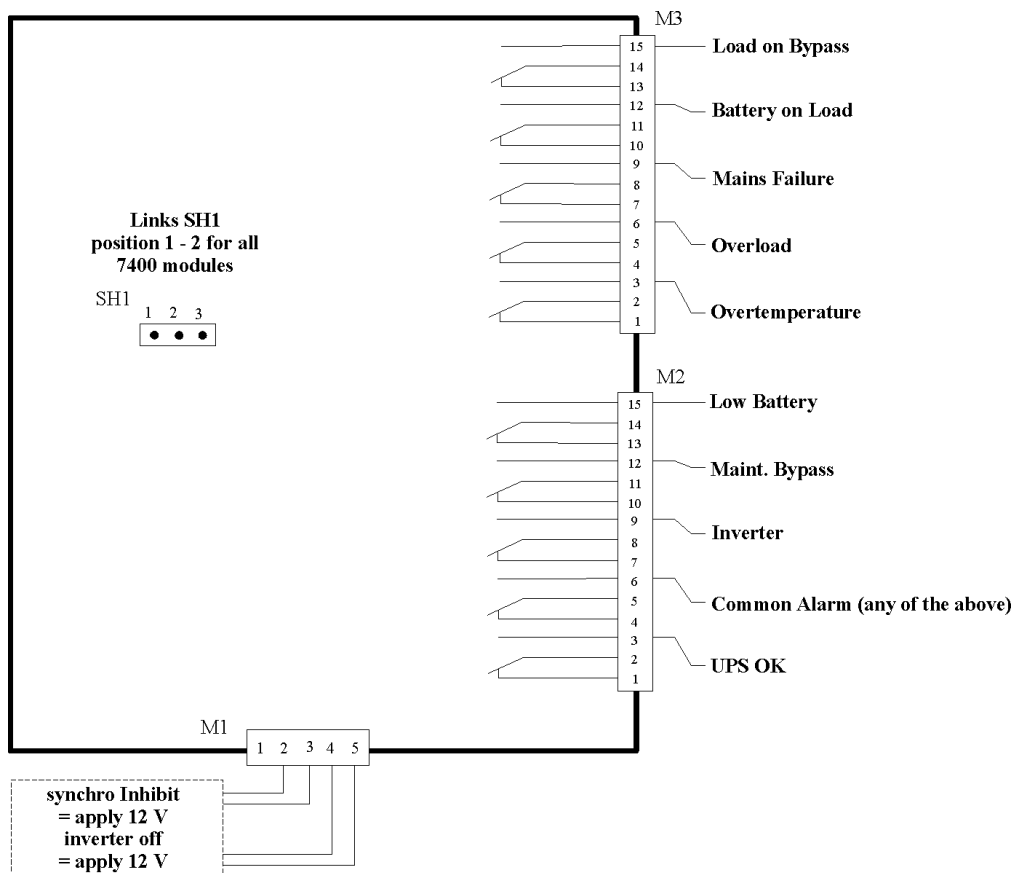

Figure 4-1 . Output Interface Board Part N°4590044E

#### 4.4 Remote Alarm Monitor (RAM) (P/N 4305001Z)

When used in conjunction with one of the alarm interface boards described previously, the Remote Alarm Monitor enables the auxiliary alarm signals to be displayed at a remote station up to 200 metres from the main equipment.

The RAM, which can be mounted either horizontally or vertically, contains a mains-driven power supply for alarm LED annunciation and displays the following warnings:

Panel Indication	Colour	Normal state	Interpretation
Inverter ON:	green	ON	Normal operating condition indicating that the load is being supplied by the inverter. This is not an 'alarm' indicator.
Utility failure:	red	OFF	When lit, it indicates that the input mains are out of tolerance.
Battery low:	red	OFF	When lit, it indicates that the battery voltage is below minimum or that the battery circuit breaker is open.
Bypass ON:	red	OFF	When lit, it indicates that the load is being fed from the bypass supply, possibly due to a UPS failure.
Maintenance:	red	OFF	When lit, it indicates that the UPS has been selected to operate on the maintenance bypass and the load is unprotected.
Alarm:	red	OFF	This is a 'common alarm' and is lit when any of the red leds described above are lit.

*Table 4-1*

An audible warning accompanies any of the above alarm conditions. This is, however, subject to a short time delay when activated in conjunction with the 'Utility Failure' and 'Bypass ON' alarms, to prevent the warning being activated by transient conditions. Pressing the 'reset' pushbutton cancels the audible warning but the alarm indications remain until the condition is rectified.

##### 4.4.1 Connections

###### Power supply

The RAM contains a single phase 220-240 Vac mains-driven power supply. Power is applied through a standard CEE22 three-pin fused mains connector located in the RAM top panel (plug provided) - use 3-core 0.5mm cable (min).

The supply is rated at approximately 4 Watts and fused at 1A.

*It is advised that this power supply is taken from the output of the UPS, otherwise in the event of a mains power supply failure the RAM will be inoperative.*

###### Alarm connections

A 9 pin D-type connector with solder points is provided with the RAM. This connector fits into the 9 pin socket on the top of the RAM and should be cabled to the AS400 Interface Board (4590041B or 4590045F), fitted to the UPS, using 9 core, 0.22mm. (minimum) cable as shown.

6310018a.02.doc

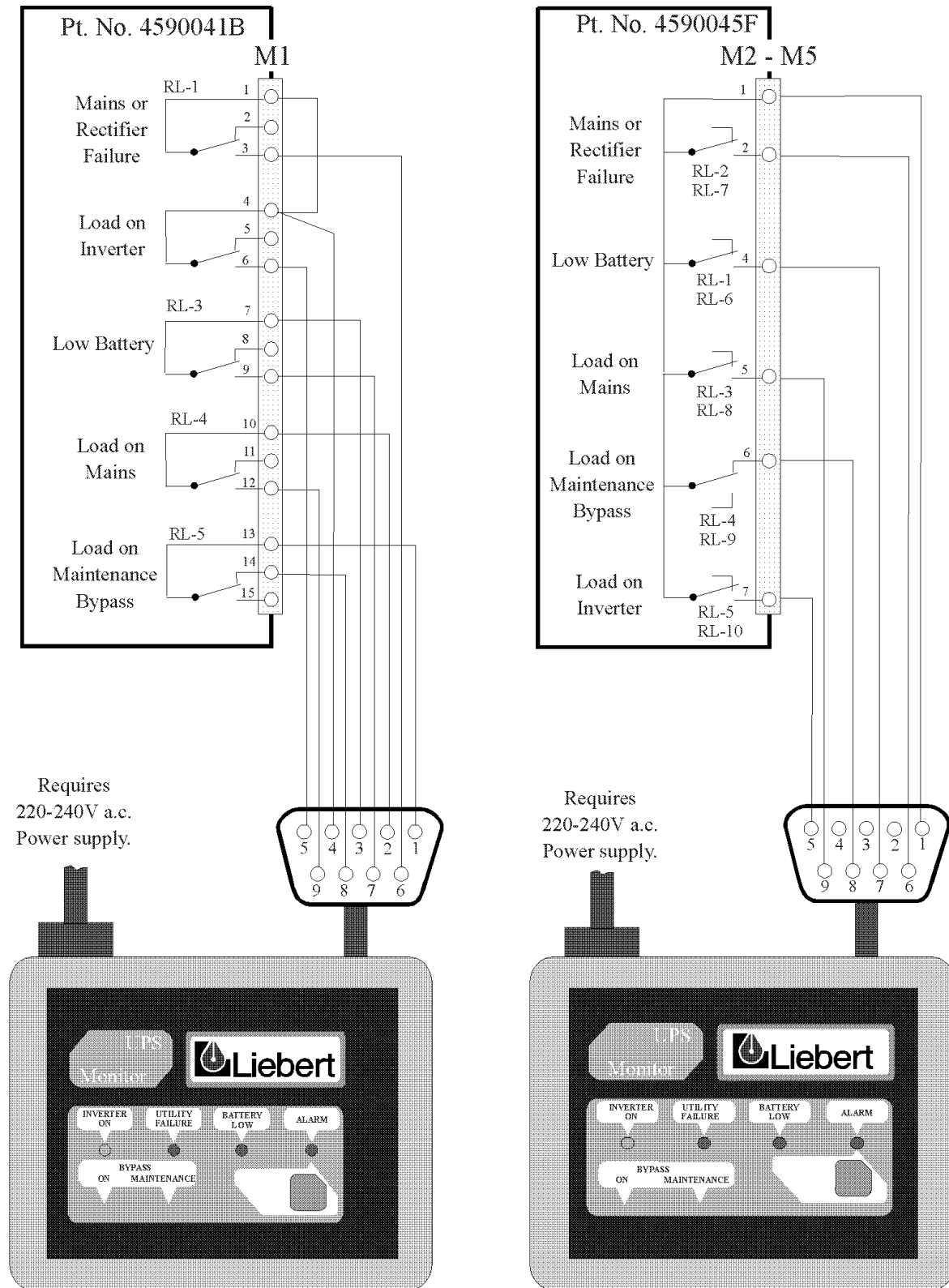

Figure 4-1 . Remote Alarm Monitor connection details

for both the single way (on the left) and four way (on the right) Interface boards.

## 4.5 Remote Alarm and Control Panel (Part No. 4305002 A)

### 4.5.1 Introduction

When used in conjunction with the Output Interface Board (4590044E) described previously, the Remote Alarm and Control Panel enables the alarm signals to be displayed at a remote station up to 100 metres away from the main equipment. In addition the panel allows the operator to switch OFF the UPS inverters.

The Remote Alarm and Control Panel, which can be mounted either horizontally or vertically, contains a mains driven power supply for alarm LED annunciation. An audible warning accompanies any of the alarm indications after a short time delay, this can be silenced by the operator.

The following list gives an interpretation of the controls and alarm facilities:

Panel Indication	Priority	Ident Fig. 4-5	Colour	Normal State	Interpretation
BATTERY ON LOAD	Alarm	8	red	OFF	This is a status alarm showing a UPS is running on the battery, this may be accompanied with a mains fault alarm and the indication from the associated UPS (6) changing from green to red.
LOW BATTERY	Alarm	9	red	OFF	This indicates that either the battery voltage is low or the battery circuit breaker is open and would normally follow the BATTERY ON LOAD (8) alarm. The indication from the associated UPS (6) will change from green to red.
OVERLOAD	Alarm	10	red	OFF	This indicates that the system has reached 100% load, after a short period of time it will be accompanied by the LOAD ON MAINS (15) alarm. The indication from the associated UPS (6) will change from green to red.
OVER-TEMPERATURE	Alarm	11	red	OFF	If an over temperature condition arises the unit involved will shut down after 3 minutes, should this exceed the module redundancy the system will switch to the bypass. This may be accompanied by a UPS FAULT alarm (13) and the indication from the associated UPS (6) changing from green to red.
MAINS FAULT	Alarm	12	red	OFF	This indicates that the mains power has either failed or is out of the specified range. This may be accompanied by a BATTERY ON LOAD alarm (8) and the indication from the associated UPS (6) changing from green to red.
UPS FAULT	Alarm	13	red	OFF	This is taken from the UPS common alarm output and would normally be accompanied with a UPS alarm and the indication from the associated UPS (6) changing from green to red.
MAINTENANCE BYPASS	Alarm	14	red	OFF	This indicates that the UPS system has been selected to run on the maintenance bypass supplies and the load is unprotected from disturbances.
LOAD ON MAINS	Alarm	15	red	OFF	This is a status alarm warning that the load is being powered through the static bypass system and is therefore unprotected.

Panel Indication	Priority	Ident Fig. 4-5	Colour	Normal State	Interpretation
UPS Module status	status	6	red/ green	ON green	These are bi-coloured indicators, when lit green indicate that the UPS is OK, and when lit red indicate that a fault is present. Indication for number 1 module is on the left and number 2 module next to it, the other four indicators are not used for this application.
Mains OK	status	21	green	ON	When lit indicates that the mains supply to the modules is OK and therefore bypass supplies are available.
Load on Mains	status	19	green	OFF	When lit indicates that the load has transferred to the bypass supplies and is therefore unprotected.
UPS OK	status	20	green	ON	When lit indicates that the UPS inverters are synchronised and UPS supplies are available.
Load on UPS	status	18	green	ON	When lit this indicates that the load is being supplied by the UPS inverters - the normal status.
UPS OFF	status	17	red	OFF	This shows that the UPS OFF switch, on the remote panel has been operated and the inverters have been shut down, the load will be supplied via the bypass if available.
UPS OFF switch		16		OFF	This switch selects all the UPS inverters OFF. It can only be used when enabled by the key enable switch (4). The UPS OFF indication (17) accompanies its operation.
Alarm silence switch		7		OFF	This switch silences the horn on the Remote Alarm and Control panel only, it has no effect on the UPS system or any indications.
UPS OFF enable switch		4		OFF	This key operated switch enables the UPS OFF switch and is security against the UPS OFF switch being operated accidentally.

**Table 4-2**

#### 4.5.2 Connections

##### **Power Supply**

The panel contains a single phase 220-240 Vac mains driven power supply. Power is applied through a standard three pin mains connector located at the top of the panel (plug provided) - use 3 core 0.5mm cable minimum.

##### **Alarm connections**

Alarm connections from the UPS modules are provided by connectors M1 (5 way terminal block), M2 (15 way terminal block) and M3 (15 way terminal block) on the Output Interface boards (4590044E), to CN1 (50 pin D-type connector) on the Remote Alarm and Control panel (4305002 A).

Full installation instructions are provided with the option kit.

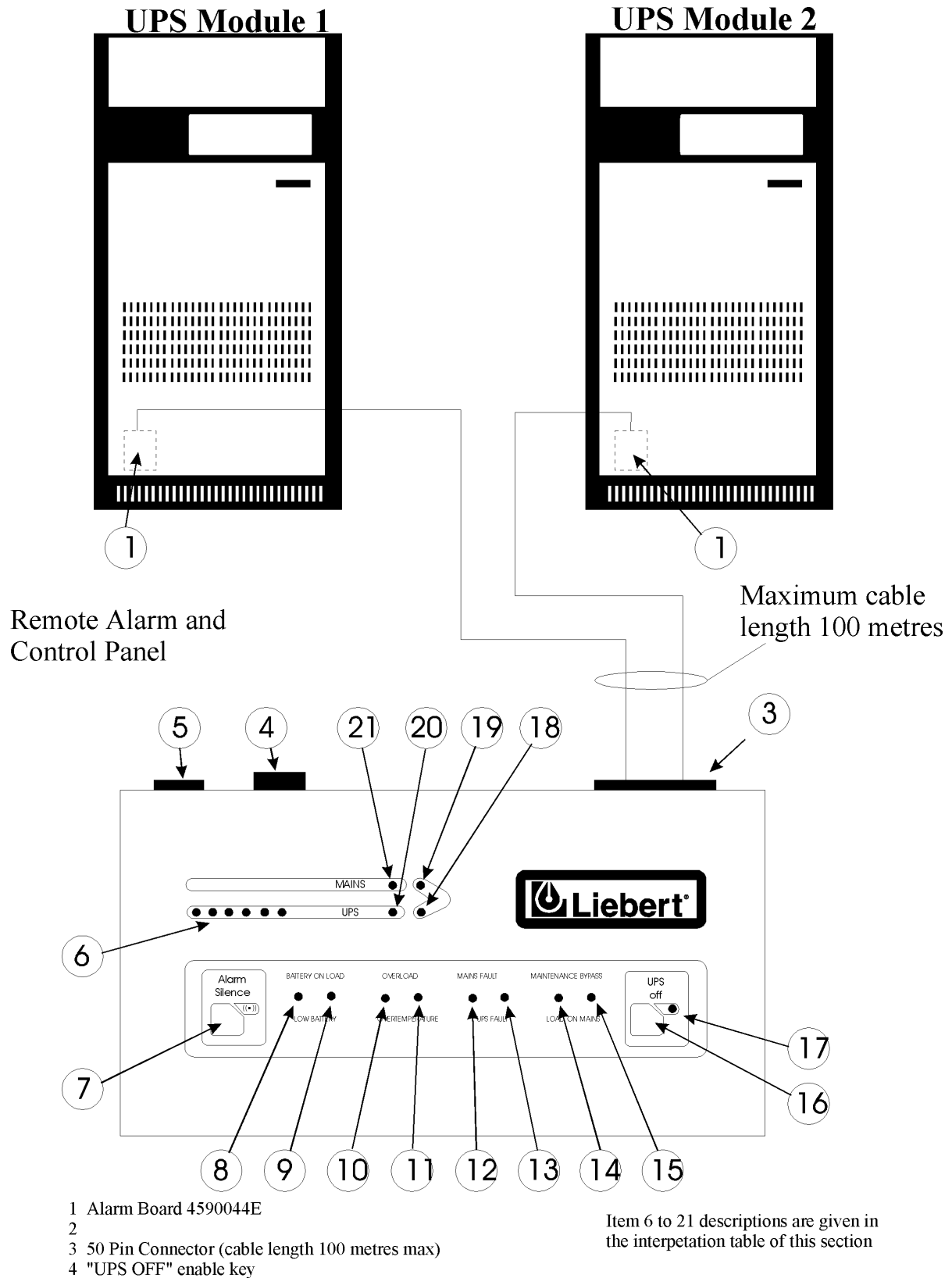

Figure 4-1 . UPS System connection and identification of the control and indication of the Remote Alarms and Control Panel

<b>UPS 1 (or Single Module)</b>	<b>Remote Alarm and Control Panel</b>	<b>UPS 2 (when 1 + 1 system)</b>	<b>Remote Alarm and Control Panel</b>
Interface board Pt. No. 4590044 E	Pt. No. 4305002 A	Interface board Pt. No. 4590044 E	Pt. No. 4305002 A
<b>M3 Terminals</b>	<b>CN1 Pins</b>	<b>M3 Terminals</b>	<b>CN1 Pins</b>
15	15	15	10
14, 11, 8, 5, 2	29	14, 11, 8, 5, 2	24
12	33	12	28
9	17	9	12
6	31	6	26
3	14	3	9
<b>M2 Terminals</b>		<b>M2 Terminals</b>	
15	30	15	25
14, 11, 8, 5, 2	46	14, 11, 8, 5, 2	41
12	13	12	8
9	16	9	11
6	32	6	27
3	49	3	44
2	50	2	45
<b>M1 Terminals</b>		<b>M1 Terminals</b>	
5	47	5	42
4	48	4	43

**Table 4-3**  
*UPS module Interface board terminal connections to Remote alarm and control panel socket pins.*

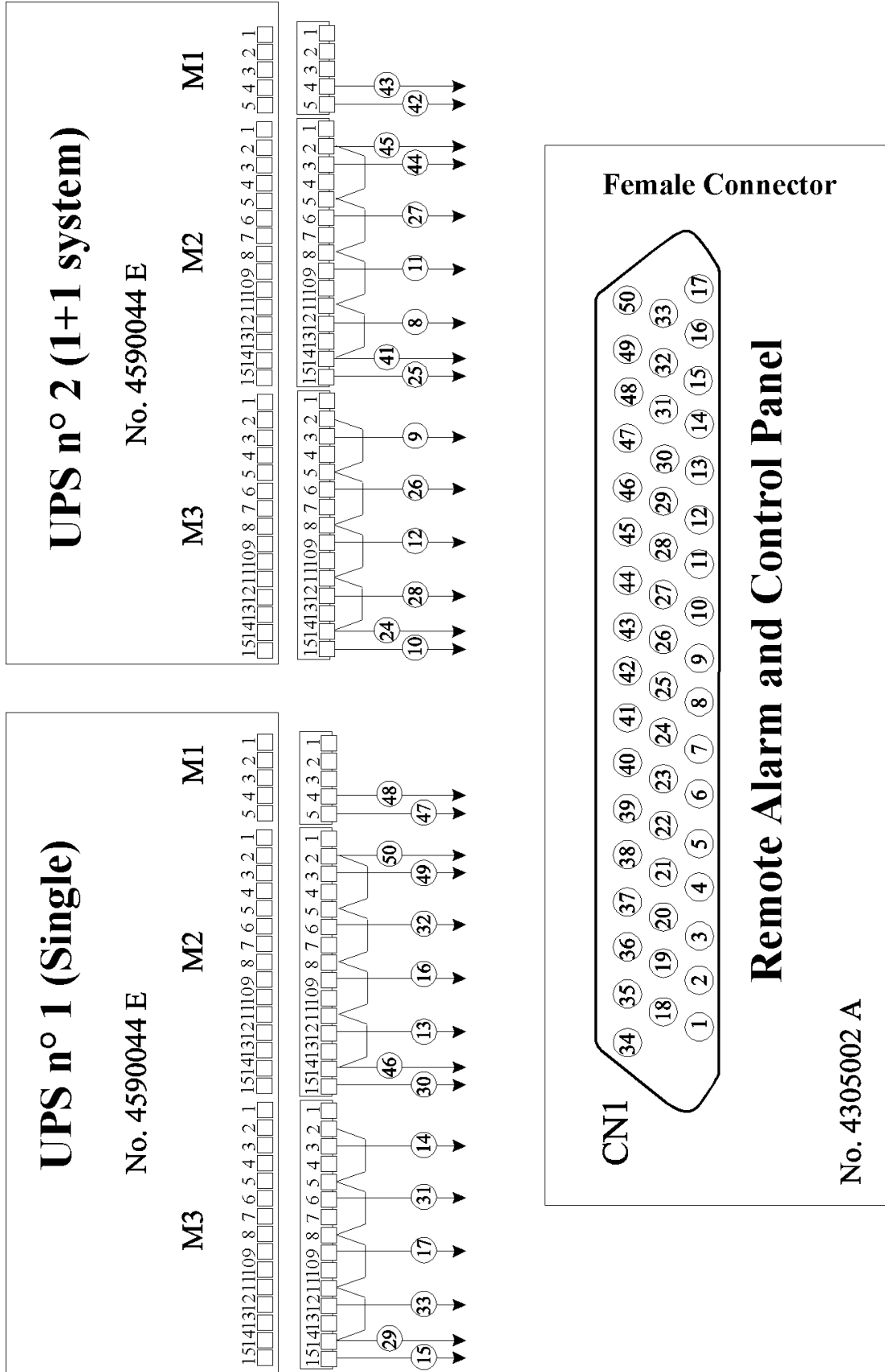

Figure 4-2 . Interconnections between the UPS modules and the Remote Alarms and Control Panel

## 4.6 RS 232 Communications Management Board (SGC) (4550002C)

### 4.6.1 Introduction

The optional RS232 Communications Management Board takes existing information available from the display assembly, stores it and converts it into a customer usable form for display either locally or remote to the UPS. It can be interrogated via a telephone-modem system from a remote service centre and it can activate a remote station in the event of an alarm to down-load the current status.

Figure 4-7 shows a typical system using the RS232 Communications Management Board, which is referred to as the SGC (Scheda Gestione Comunicazione). One would be fitted to the MSSC for system information and one to each UPS module for individual module information. The SGC has two outputs; the first, as shown, is the modem connection and the second connects directly into a PC for local monitoring where required.

Remote communications can be via a dedicated telephone line or a non dedicated line, in the second case a "Data Switch" will be required to select the modem connected to the UPS when required.

The information stored on this board is maintained in the event of a UPS shutdown by (alkaline) batteries. These batteries also maintain an on-board clock which times and dates events as they occur.

The SGC board continually stores information on the dynamic power parameters within the UPS. Four hundred of these events are stored in a recirculating memory, the most recent displacing the earliest in the 'Power History' store. A similar 'Event History' store tracks the changing operational status of the machine. This memory reflects the alphanumeric display on the front panel and updates whenever a change takes place. The message would normally read 'NORMAL OPERATION' but would change when a 'WARNING' or 'ALARM' condition occurred. If an 'ALARM' occurs the SGC board marks the event in the 'Power History' and after a further 199 events, the system locks out any further updates. This gives a snap-shot of the events on either side of the alarm.

On 'ALARM' the SGC board can be configured to automatically dial out to the remote site or service centre. Two telephone numbers can be stored within the memory. The primary number will be tried preferentially but the system will revert to the secondary number should the primary connection prove unsuccessful.

An LED located on the SGC board flashes at two hertz per second when communication is taking place.

A software package is provided with the option to be used with the PC. This software is used to configure the system and to run the diagnostics. It has a screen driven menu with an on screen help facility. The software can be operated in several languages which are set up at the terminal. Each terminal can be set up to monitor 1000 UPS.

The remote terminal, as well as receiving information from the UPS, can interrogate the system. It can do this in two ways:

1. Manual input from the keyboard will allow the operator to select any one of the UPS on the system and request the current status.
2. The operator may select any or all the UPS from a list residing in the computer and call automatically, overnight if necessary.

#### 4.6.2 General Information

within

The system is made up of the following parts or sub-systems:

1. RS 232 Communications Management Board (SGC), for installation the UPS.
2. Batteries:  
these may be of any non-rechargeable type (alkaline, 'environment-friendly', etc.) as long as they are of the correct size (AAA).
3. Personal computer for local connection
4. Flat, 25-wire cable ending in two 25 pin connectors, one male and one female, for UPS-PC connection.
5. Digital telephone modem for connection to the board.
6. Flat, 25-wire cable ending in two 25 pin connectors, one male and one female, for local UPS- modem connection.
7. Personal computer plus digital telephone modem for remote station.
8. Flat, 25-wire cable ending in two 25 pin connectors, one male and one female, for remote modem-PC connection.

The possible types of connection, as shown in figure 4-8 , are as follows:

##### ***Direct Connection***

This type of connection requires items 1, 2, 3, and 4 from the above list. It is possible to obtain data from a distance of upto 15 metres through the EIA RS232E interface.

##### ***Remote Connection (i.e. via telephone modem)***

This type of connection requires items 1, 2, 5, 6, 7, 8 and a commuted telephone line.

##### ***Complete Connection***

Complete connection require the total resources of the above.

Full installation and operating instructions are supplied with the option.

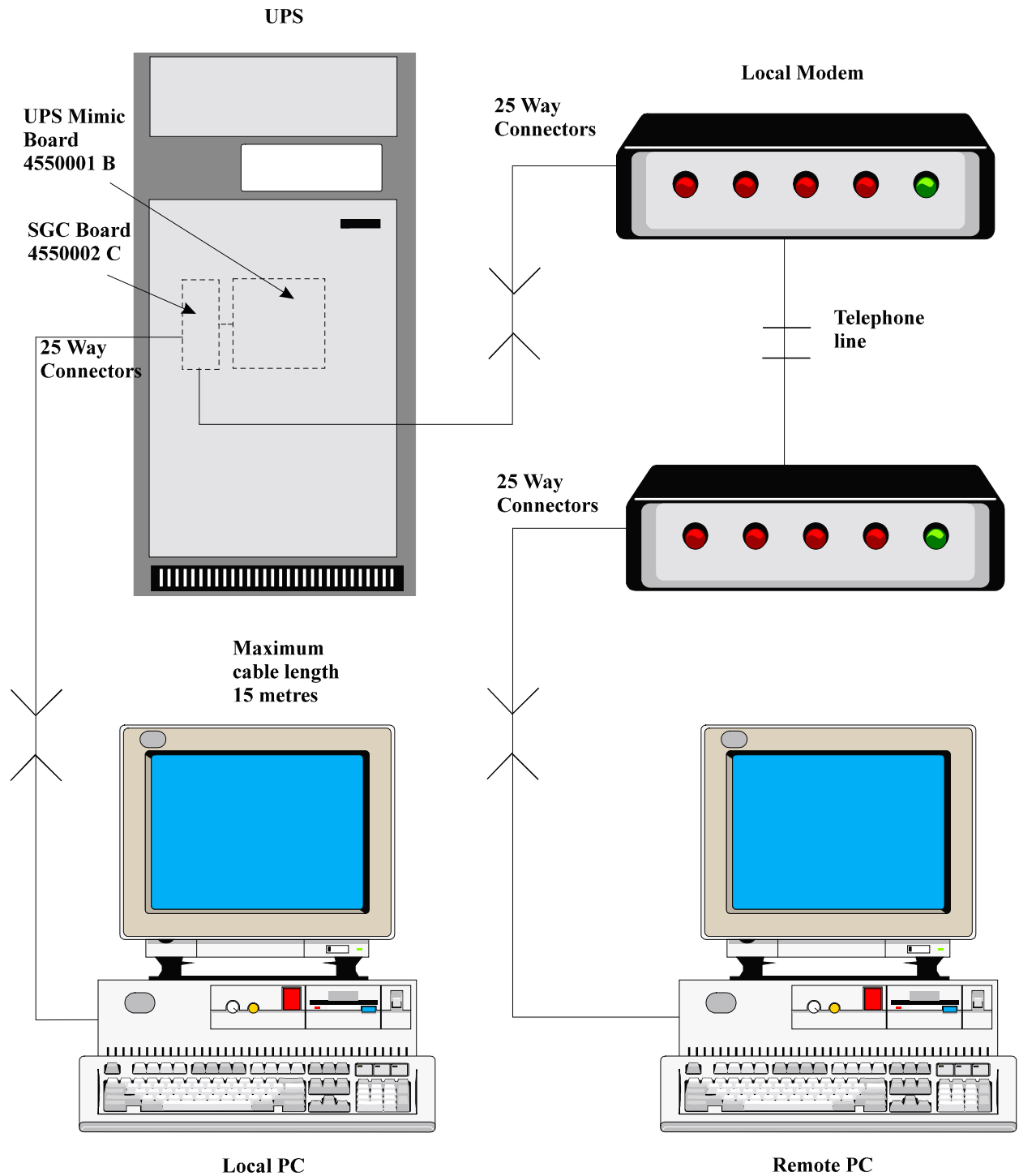

Figure 4-1 . Typical Series 7400 RS232 Communications configuration

## 4.7 5th Harmonic Input Filter

### 4.7.1 Introduction

An optional input 5th harmonic filter can be added to the 6 pulse 7400 series UPS to improve the UPS input power factor and reduce the amount of electrical noise reflected into the input three phase supply.

On units upto 200 kVA the filter components are contained in a purpose-built cabinet which is positioned alongside the main UPS equipment and connected in series with the UPS input supply. In the case of the 300/400 kVA models the input filter is located within the UPS as illustrated in figure 4-12. The filter components are matched to the UPS capacity, resulting in different part numbers for each system as follows:

	Part No.	Weight
80kVA filter cabinet	5331016 C	220kg.
120kVA filter cabinet	5331018 E	240
kg.200 kVA filter cabinet	5331020 G	280
kg.300 kVA filter (internal)	4641010 K	N/A
400 kVA filter (internal)	4641013 N	N/A

### 4.7.2 Specification

Input voltage	380-400-415, three phase.
Input voltage tolerance	±15%.
Nominal frequency	50Hz.
Input frequency tolerance	±5%.
UPS input current distortion	10% max. at full load.
UPS input power factor	>0.9 lag.
Dimensions (80-120 kVA)	600 x 800 x 1800 mm.
Dimensions (200 kVA)	600 x 800 x 1900 mm.

### 4.7.3 Notes on connection

The 80 - 200 kVA module input filters have a manually operated isolator I2 plus internal fuse protection. The 300 kVA and 400 kVA filter when fitted is connected permanently in circuit between the UPS input isolator and inductor L1. The circuit position of both types of filter are shown in figure 4-8.

The block diagram in figure 4-9 and the models' connections in figures 4-9, 10, and 11, illustrate the installation with a "split bypass" supply configuration.

*Note:* The input Neutral connection must always be connected to the bypass input 'N3' on the UPS.

If the UPS is configured to operate with a "common bypass", a three phase supply with a separate neutral, or a standard four wire input, may be used. The bypass supplies may be linked via the input connections of the filter input isolator I1 or at a junction box/external isolator prior to the supplies entering the filter cabinet. Ensure all internal links between the UPS input and bypass bus bars are removed so that the filter does not carry any bypass supplies. The Neutral must be terminated at the UPS bypass input terminal 'N3', as shown in figure 4-11 for the 200 kVA model.

*Note:* The Neutral connection 'N1' on each input filter Isolator I1 is a convenient point to terminate or link the Neutral cable. It is not connected internally to the input filter.

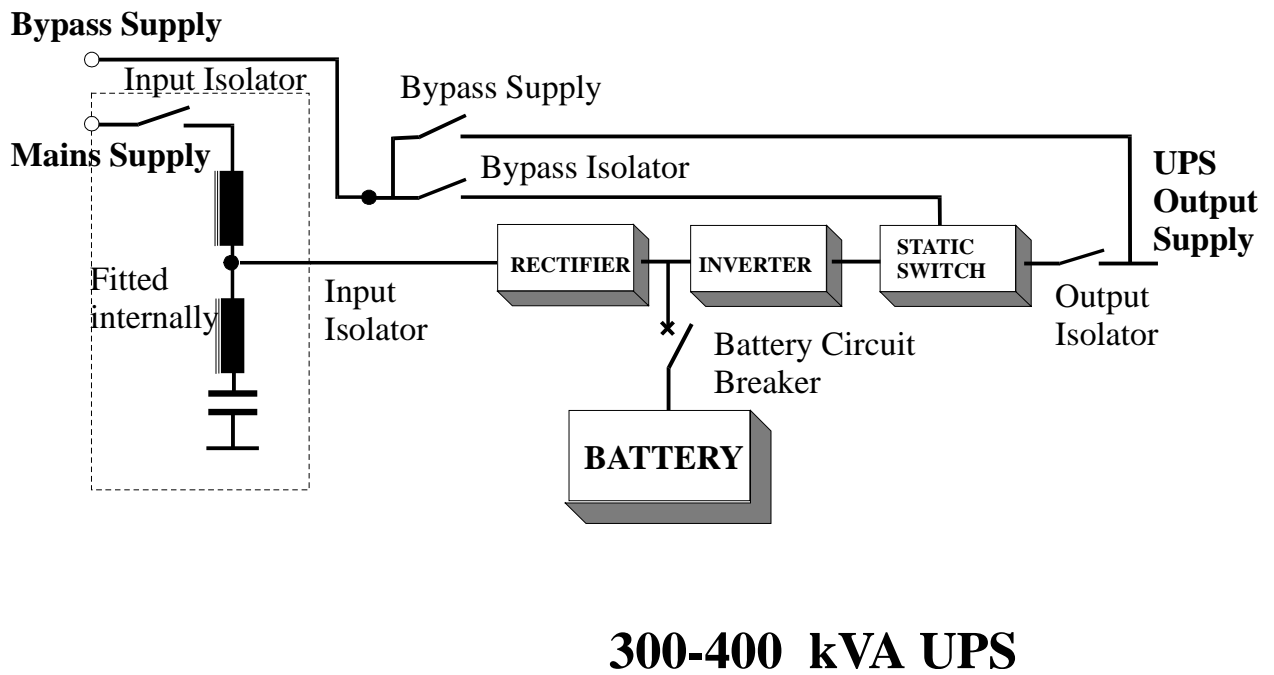
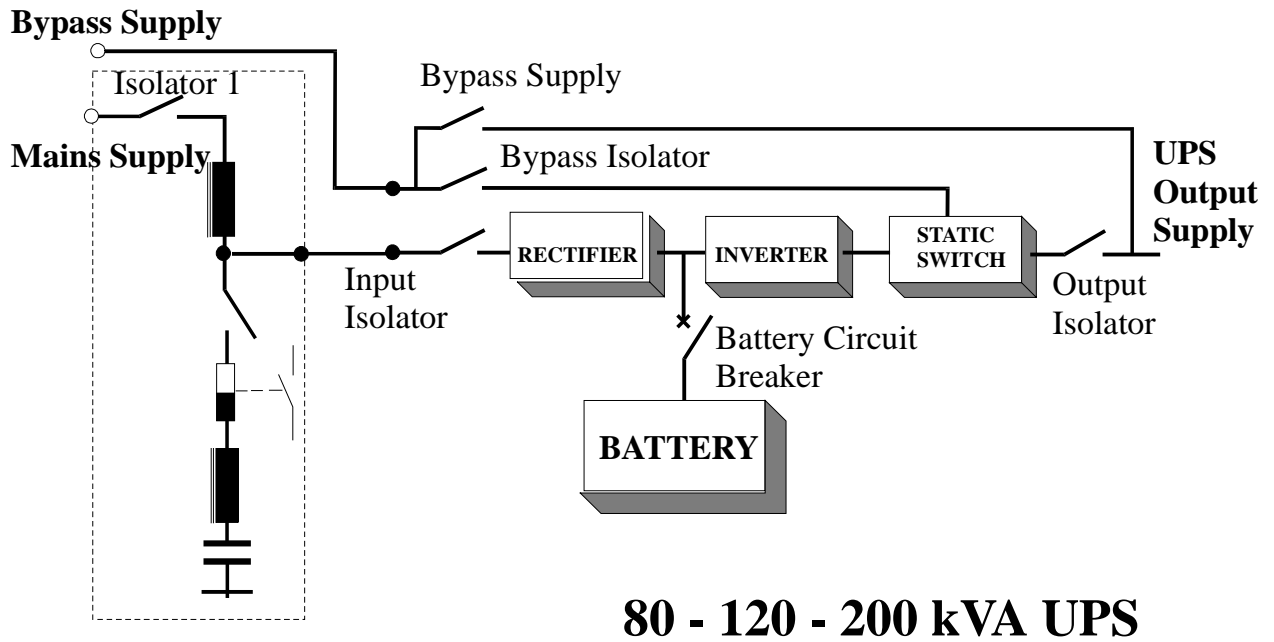

Figure 4-1 . Block diagram of Input Filter and UPS

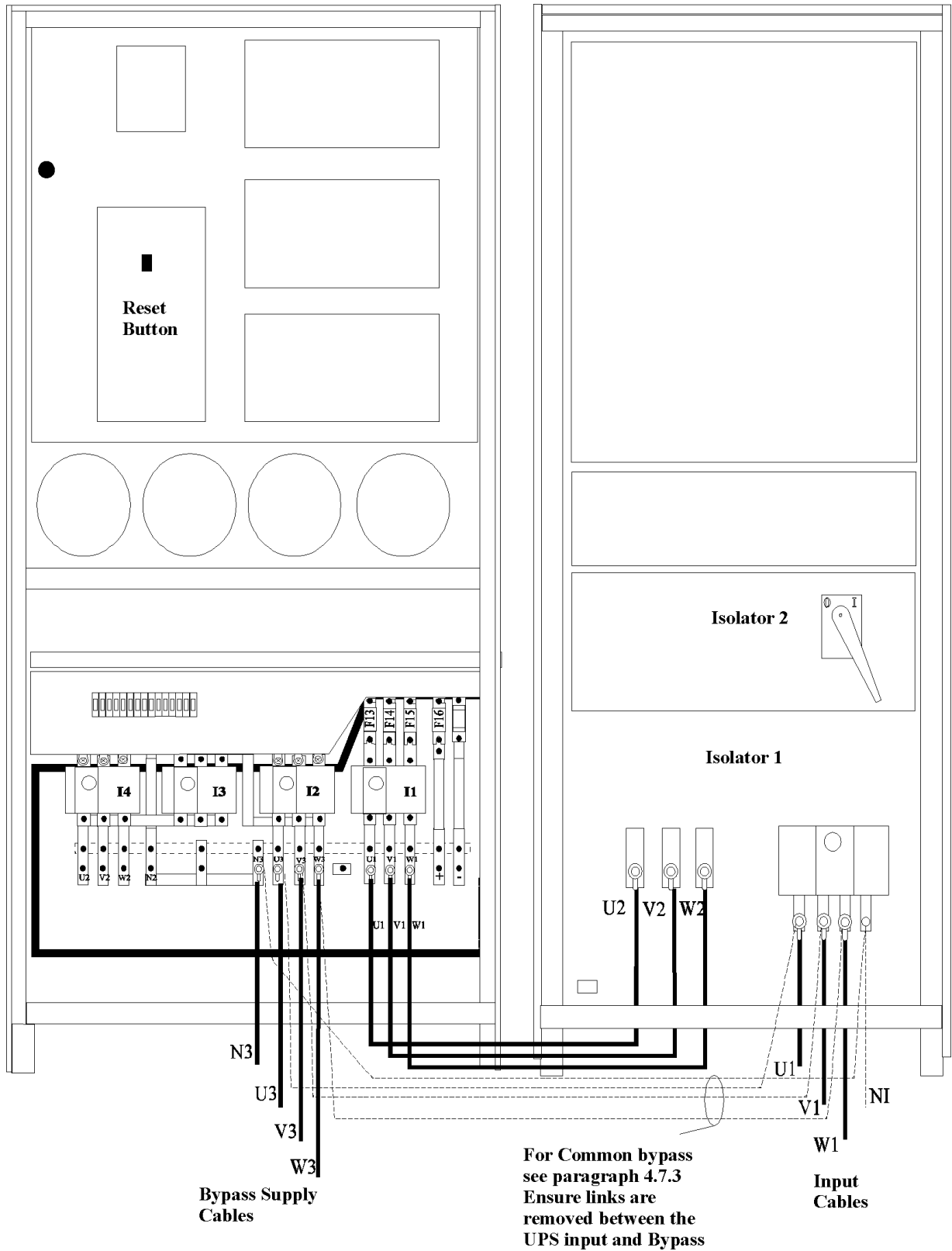

Figure 4-2 . 80 kVA Input Filter cabinet connections

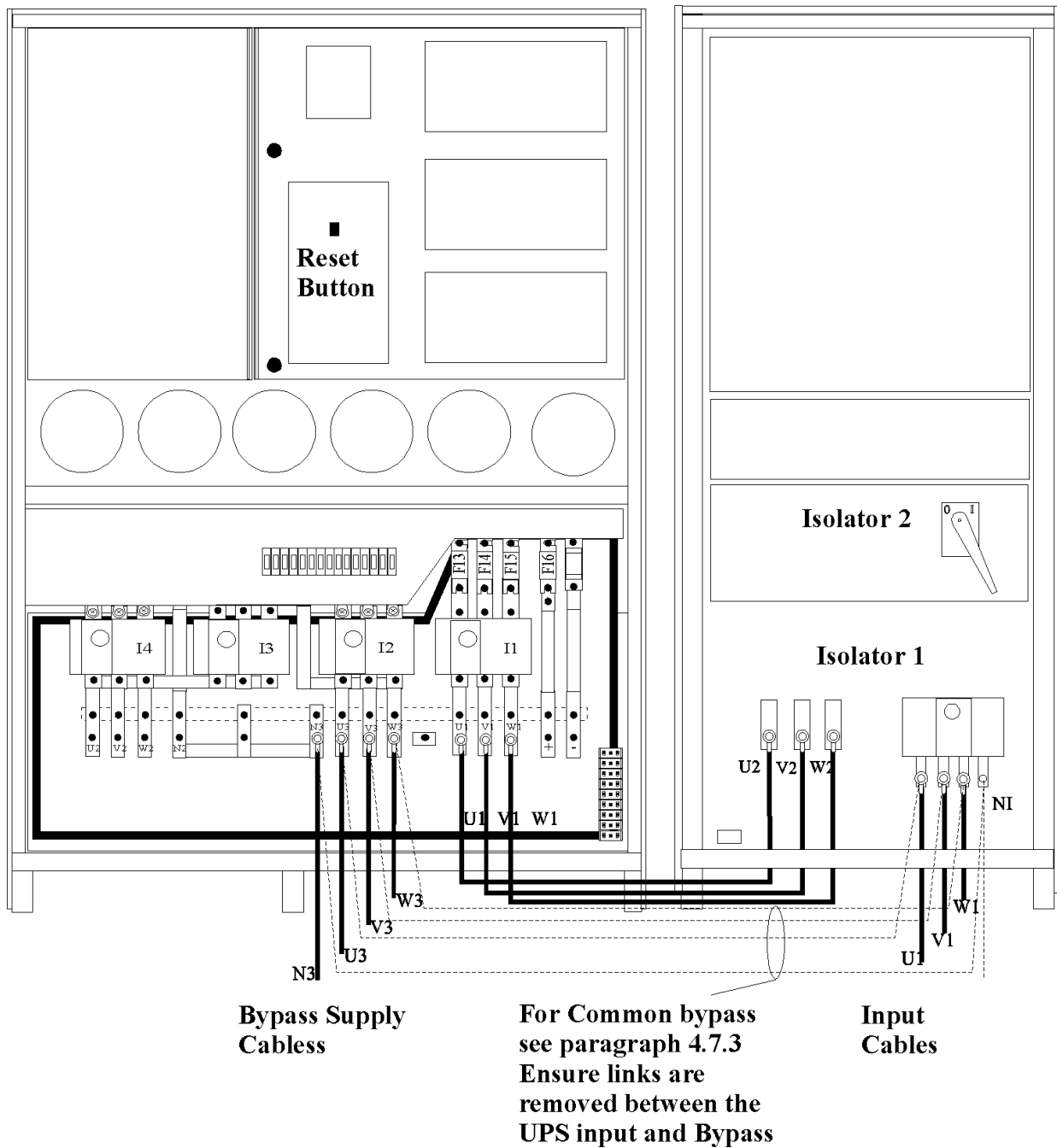

Figure 4-3 . 120 kVA Input Filter cabinet connections

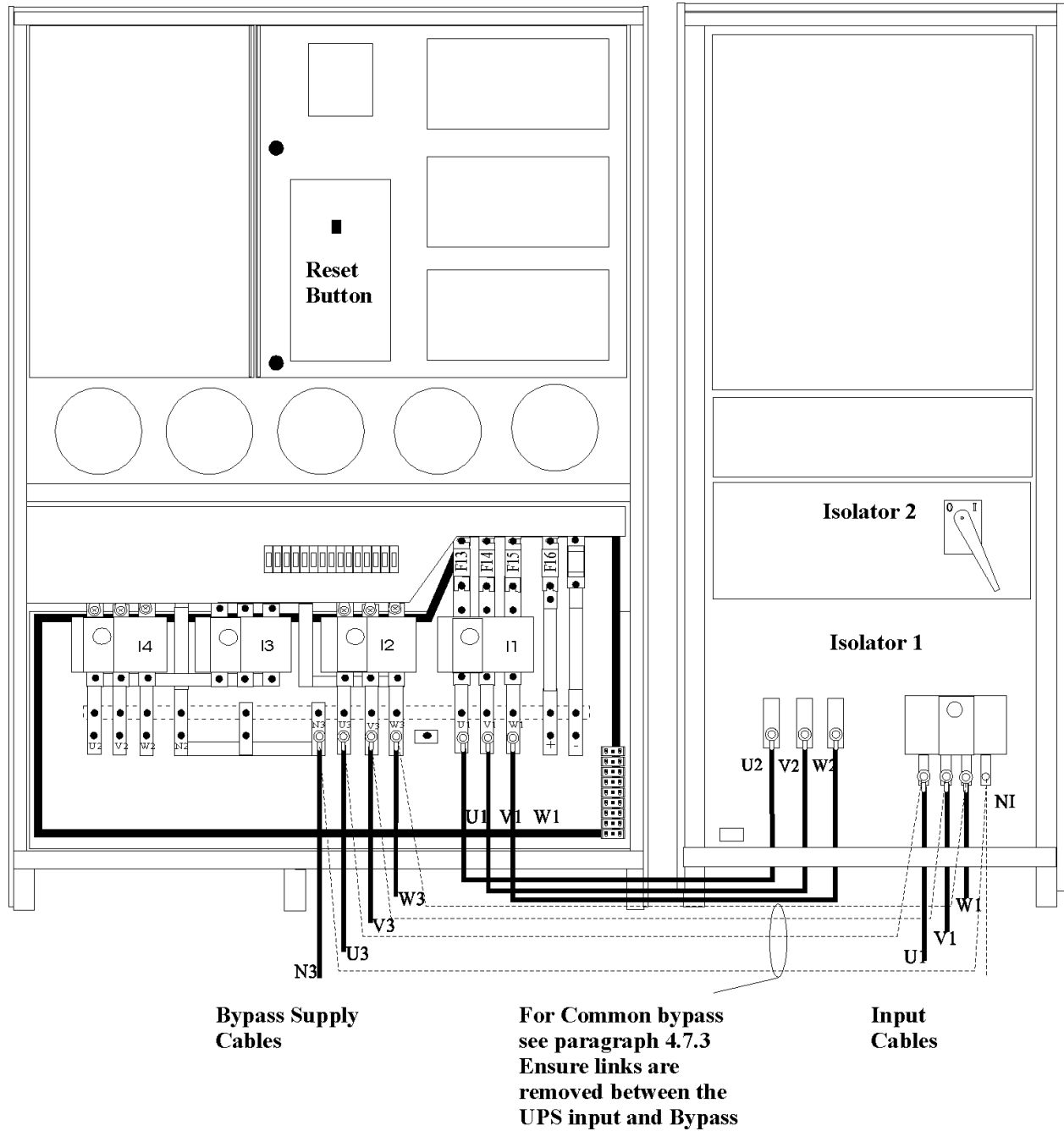
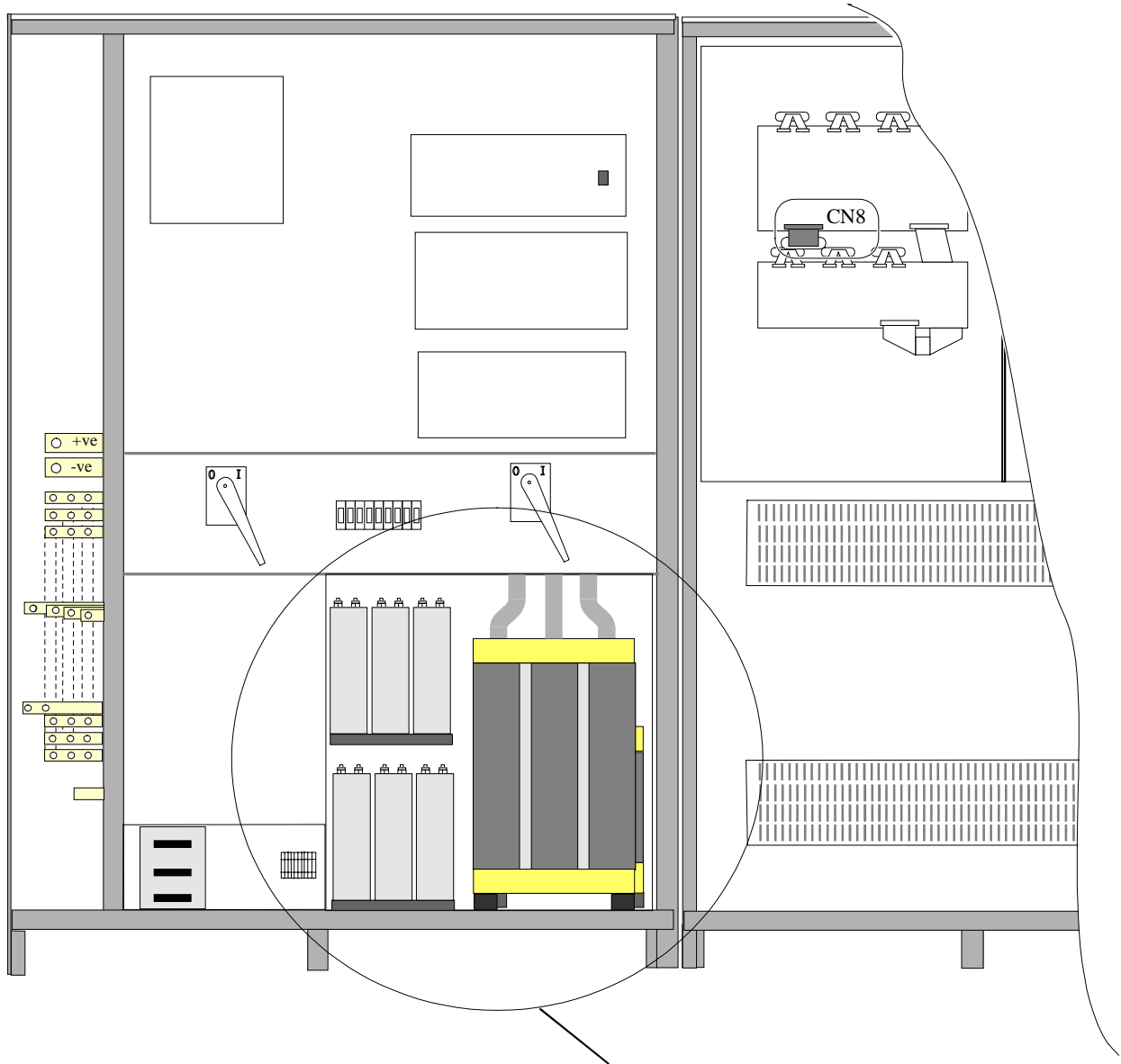

Figure 4-4 . 200 kVA Input Filter cabinet connections



**Internal Input Filter**

*Figure 4-5 . 300-400 kVA Input Filter location*

## 4.8 Cable top entry kit

### 4.8.1 Introduction

This modification kit is for use with 80 kVA 120 kVA and 200 kVA models only.

As can be seen in figure 4-13 this kit comprises front, rear and top panels which when assembled using the extension brackets and existing UPS end panel, allows you to extend the UPS width by approximately 200mm. This then allows cable entry through the top aluminium panel. It is necessary for the user to size and cut holes in the top panel for the cables to be used.

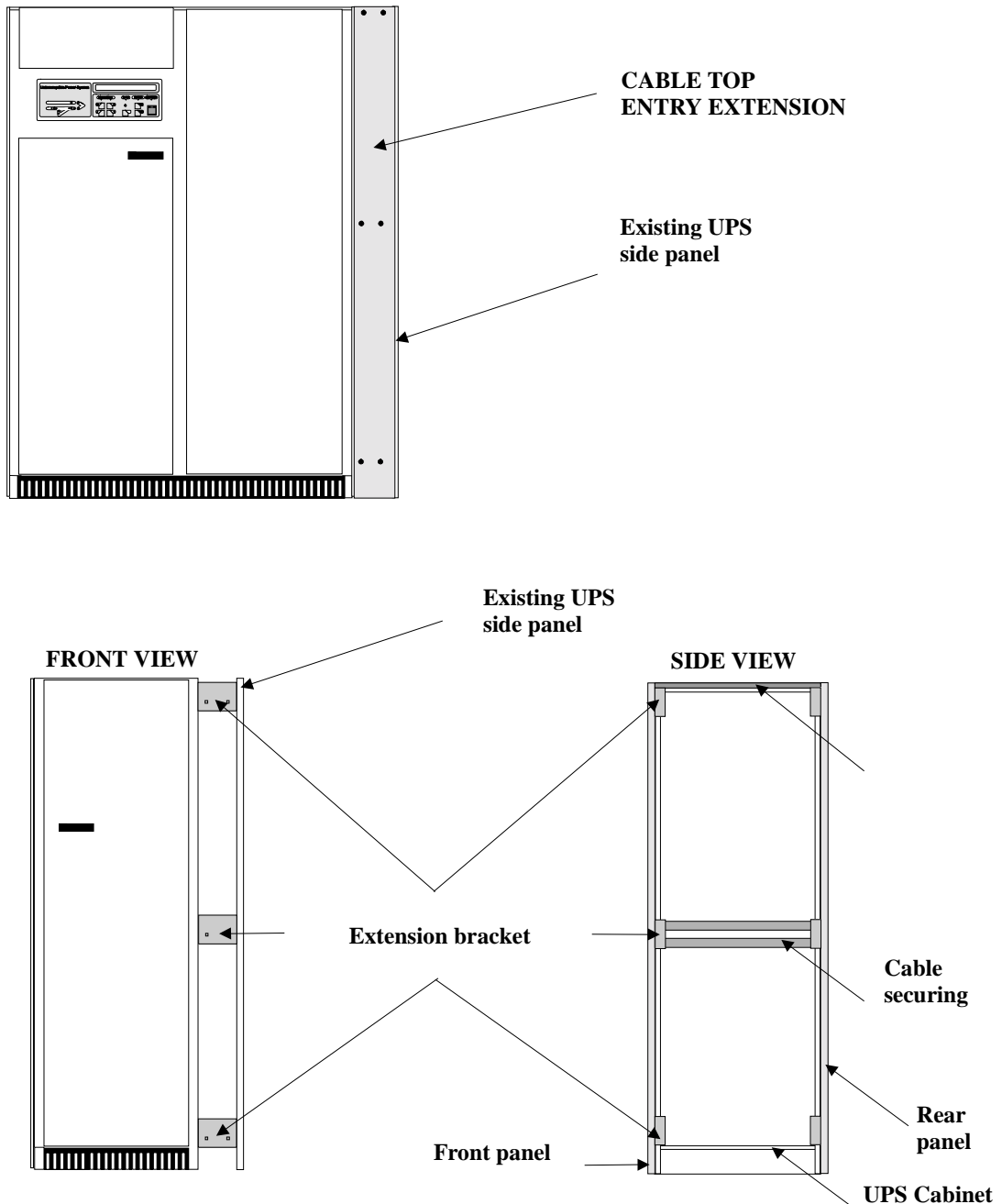

Figure 4-1 . Cable Top Entry Kit

## 4.9 Pulse Option

### 4.9.1 Introduction

The 12 pulse option for the series 7400 UPS is normally factory fitted. The power and control cable connections for all units are identical to those given in chapter 3 of this manual. The 300/400 kVA units have the option fitted into the existing cabinet. However, for 80, 120 and 200 kVA units with part numbers as indicated in the front of this manual, the option can be fitted on site by a Liebert certified service engineer. The option is fitted into a purpose designed cabinet that when bolted to the side of the UPS cabinet extends the system width by 400mm. As with all series 7400 bolt-on options, the mechanical connection is achieved by removing the UPS cabinet side panel; the additional cabinet is then bolted on to the UPS cabinet at the four corners; the side panel removed from the UPS cabinet is then fitted to the additional cabinet side wall to complete the system.

### 4.9.2 Electrical connection

For electrical connection of the 12 pulse option part no. 53320001 Z for 80 kVA unit 5332002 A for the 120 kVA unit and 5332004 C for the 200 kVA refer to figures 4-14 and 4-15 and the following instructions.

The details given in figure 4-15 refer to the 80kVA unit. The 120kVA and 200 kVA units are identical except for the following identification numbers:

	80kVA	120kVA	200kVA
Connector ident	CN3	CN4	CN4
Extractor fan	VL8	VL10	VL12

### **WARNING**

*BEFORE STARTING INSTALLATION OF THIS OPTION ENSURE ALL EXTERNAL ELECTRICAL POWER SUPPLIES ARE SWITCHED OFF AND MADE SAFE. DISPLAY THE RELEVANT NOTICES. ENSURE THE BATTERIES ARE ISOLATED FROM THE UPS. CARRY OUT VOLTAGE CHECKS ON ALL INPUT, OUTPUT AND BATTERY CONNECTIONS..*

1. Gain access to UPS interior, open upper hinged panel. Remove the bus bar +ve and -ve connection links from between the rectifier output and the d.c. bus bar.
2. Connect cable 88 from the option cabinet TC4 to the UPS rectifier output +ve bus bar.
3. Connect cable 89 from the option cabinet L2 (term A1) to the UPS rectifier output -ve bus bar.
4. Connect cable 49 from the option cabinet L2 (term B) to the UPS d.c. bus bar +ve connection.
5. Connect cable 50 from the option cabinet L2 (term A) to the UPS d.c. bus bar -ve connection.

6. Connect cables 4, 5 and 6 from the option cabinet AT1 (terminals A, B and C) to the UPS input inductor L1 (terminals A', B' and C').
7. Connect flat cable FC22 from the option cabinet PCB 4590051L (connector CN1) to the UPS PCB 4520073Z (connector CN9).
8. Connect flat cables FC19, FC20 and FC21 from the option cabinet PCB 4612141 B (connectors CN1, CN2 and CN3) to the UPS PCB 4520073Z (connectors CN6, CN7 and CN8).
9. Connect wire No.80 from the option cabinet fan CN3 (1) to the UPS fuse F12.
10. Connect wire No.82 from the option cabinet fan CN3(2) to the UPS fuse N.
11. For UPS 200 kVA only: move wires No. 46/48 from terminal 4 to terminal 2 of TA1 - TA2 in the UPS.

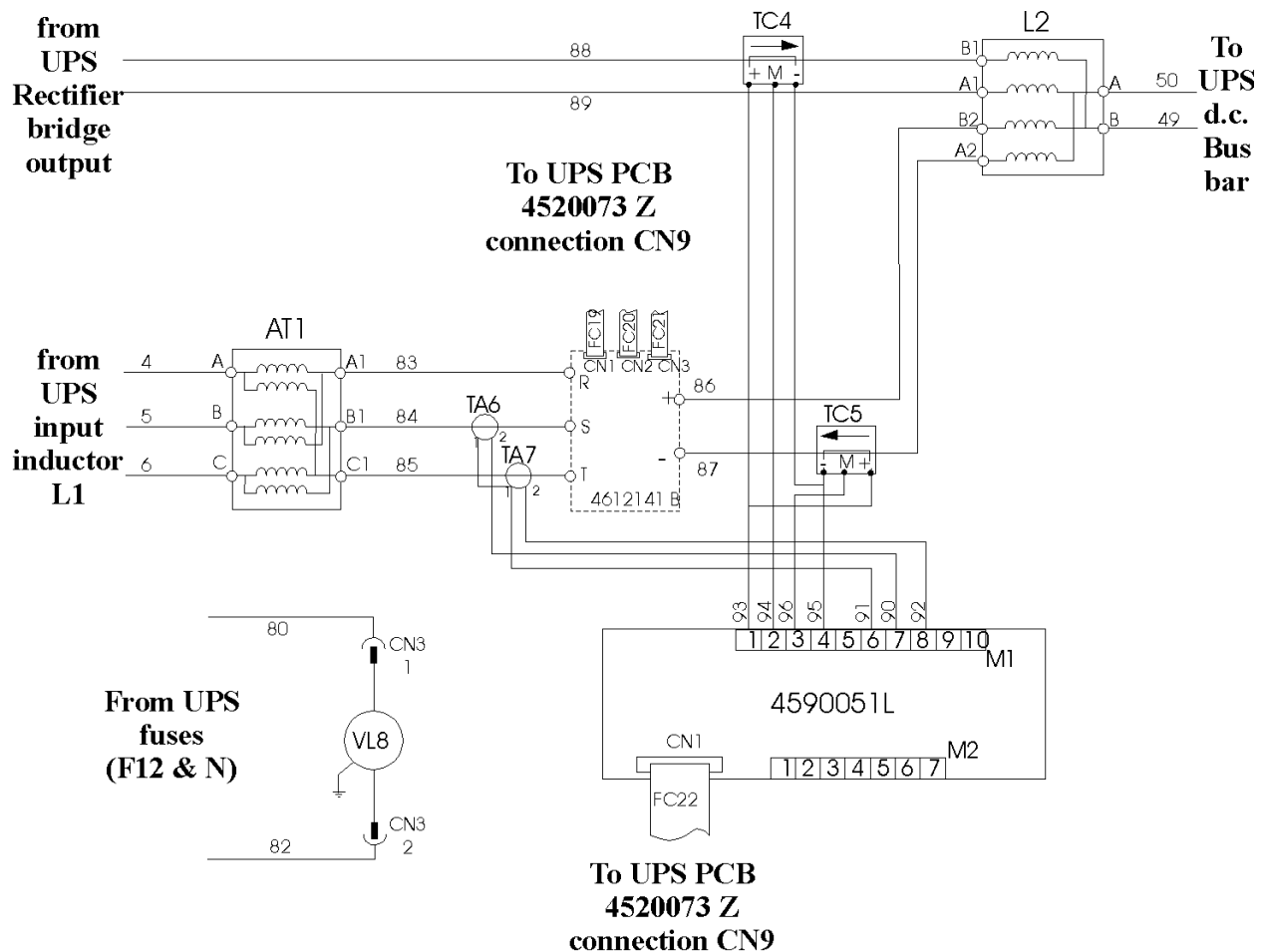

Figure 4-1 . Electrical schematic of 12 Pulse option cabinet

**This completes the electrical connection of this option.**



6310018a.02.doc

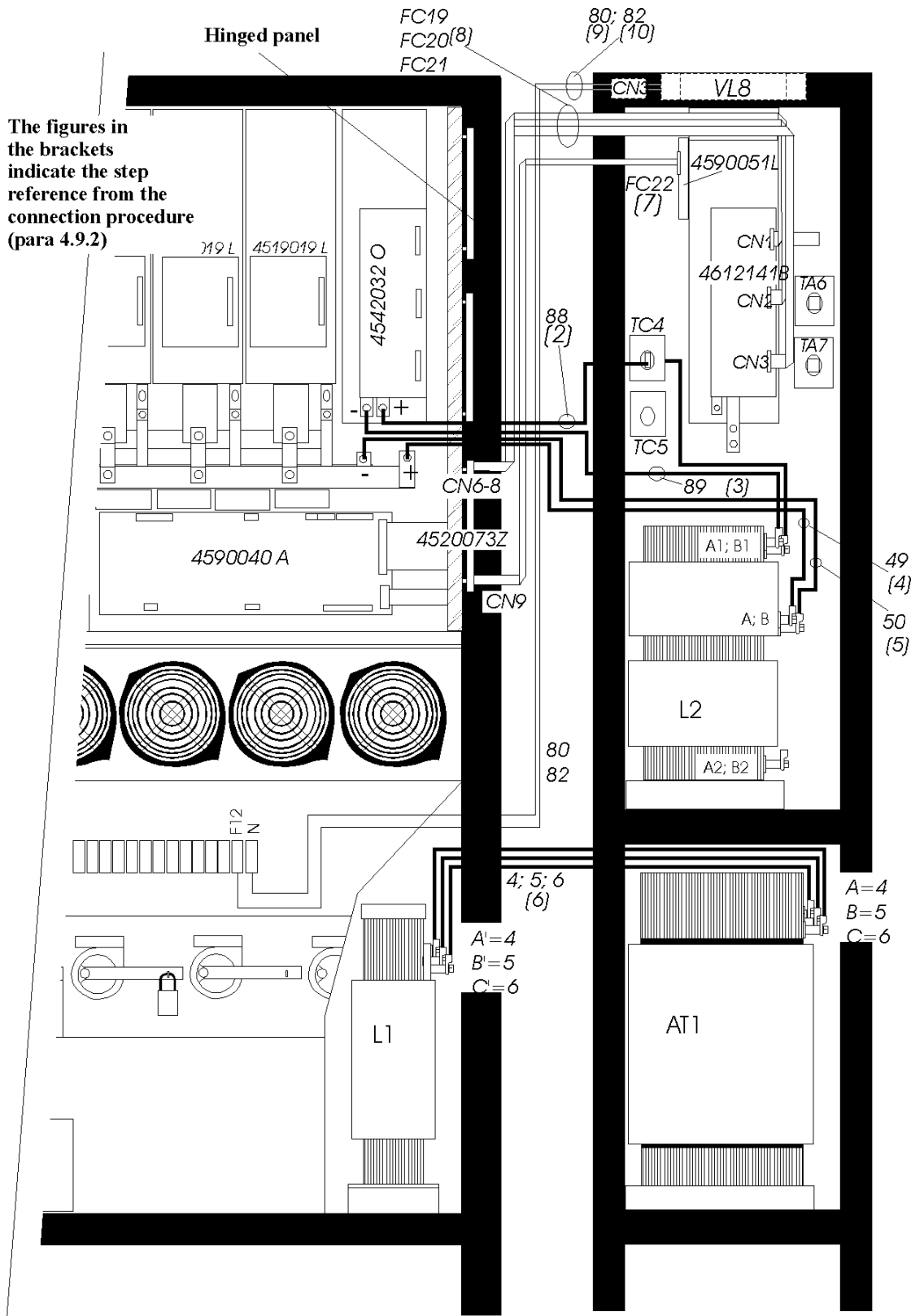

Figure 4-2 . 12 Pulse option cabinet

## 4.10 Option Board Kit (Part no. 77000005)

### 4.10.1 Introduction

This kit is intended for use in to any Series 7400 UPS fitted with the appropriate Rectifier Logic Board (part no. 4520073Z). The kit provides the following facilities:

ρ *Battery temperature compensation:*

With this feature fitted and enabled the nominal float voltage supplied to the battery is adjusted so as to be inversely proportional to the ambient battery cabinet/room temperature ( as monitored by a remote temperature sensor ). This prevents the battery being over charged at high ambient temperatures.

*Example:* - the d.c. float voltage is reduced by 1.5V d.c. per oC rise in battery Temperature from 25oC to 35oC.

ρ *Reduced input current limit:*

This facility allows the UPS input current limit to be reduced to a predetermined level. This may be necessary when running the UPS on a standby generator. The system is activated by the closure of a normally open contact. The input current limit can be reduced from 115% to 50% of nominal.

ρ *Reduced battery current limit:*

This facility allows the UPS battery current limit ( i.e. the magnitude of the battery charging current) to be reduced to a preset value. This may advisable if the battery cabinet/room ventilation system failed. The system is activated by the closure of a normally open contact. The battery current limit can be reduced from 100% to 10% of its initial setting.

### 4.10.2 Installation

Unpack the kit carefully and examine the parts for any signs of transit damage . Check that the following items are included in the kit:

1	77000002	PCA Option board.
1	83696005	Temperature sensor kit.
4	49030060	Screws (M3 x 6).

Fit the supplied equipment as follows:

1. If the module is operating and on load, transfer the load to bypass and open the input isolator (I1) following the instructions in chapter 2 of this manual.
2. Locate onto the plastic stand-offs and secure the option board into position as shown in figure 4-16 using the screws provided.
3. Fit links into position on the option board for the features required. See table 1 for enabling link positions
4. Connect 10 way ribbon cable between PL1 on the option board and connection CNx on the Rectifier Logic board following existing cable routes.
5. The remote temperature sensor required for the battery temperature compensation feature should be located in such a position so as to monitor the ambient air temperature of the battery bank. It is recommended that the remote sensor is connected to the option board using a twisted pair (1-2 mm<sup>2</sup>) of maximum length 25m.



6310018a.02.doc

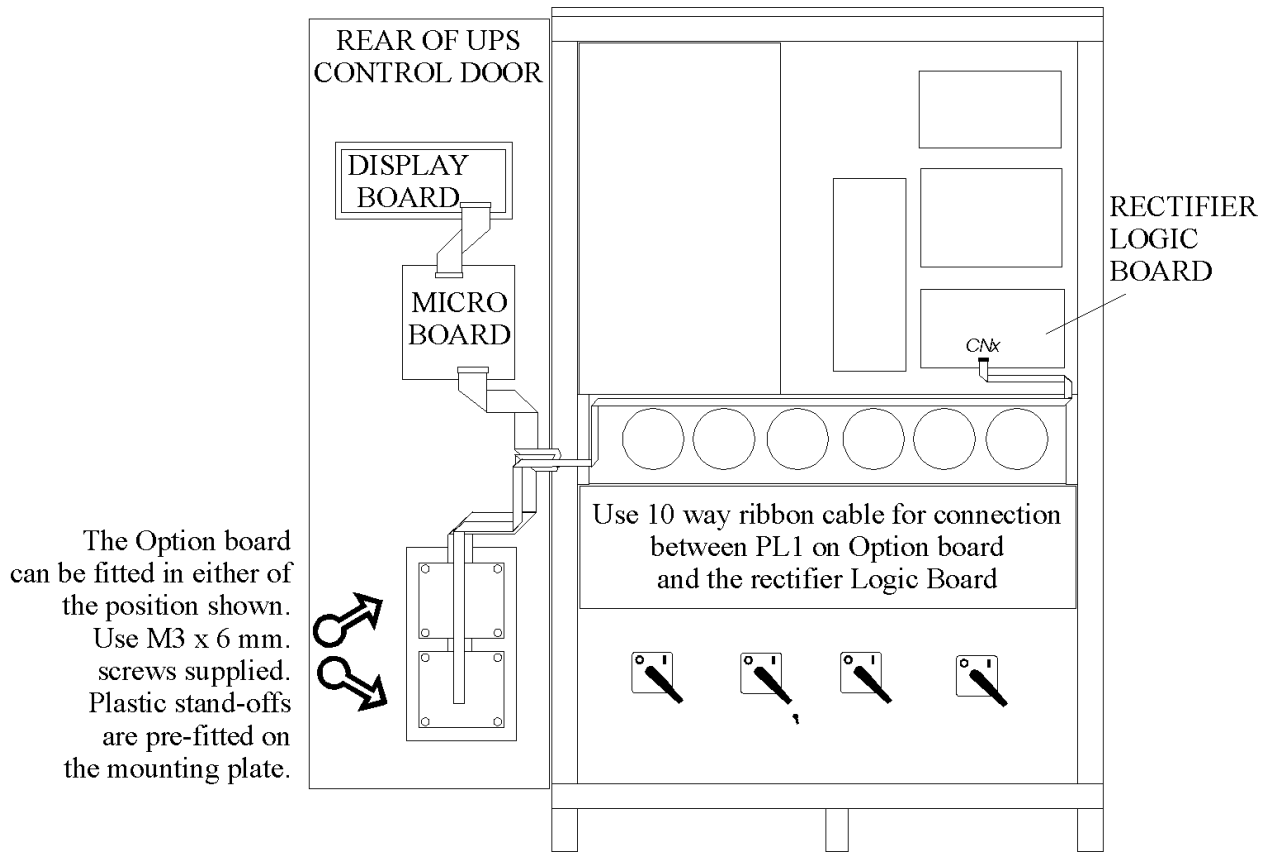

Figure 4-1 . Option board fixing location

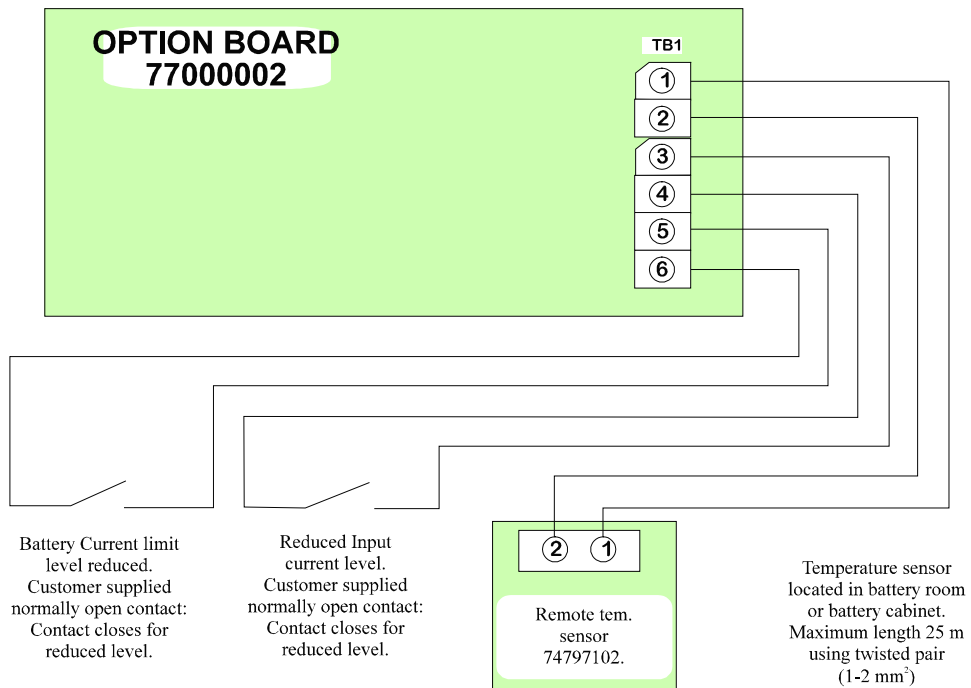

Figure 4-2 . Option board connection and layout

6. Connect auxiliary wiring required as shown in figure 4-18
- |   |   |                  |
|---|---|------------------|
| Battery charging temperature compensation temperature sensing element | - | TB1-1 and TB1-2  |
| Reduced input current limit normally open contacts                    | - | TB1-3 and TB1-4  |
| Reduced battery current limit normally open contacts                  | - | TB1-5 and TB1-6. |
7. Calibrate the options using instructions sheet part number 77000008.

SHUNT	LINK POSITION	DESCRIPTION
1	1-2	Reduced Input current limit Calibration Mode.
	2-3	Normal Operation.
2	1-2	Reduced Battery current limit Calibration Mode.
	2-3	Normal Operation.
3	1-2	Reduced Input current limit: Link fitted - System enabled Link not fitted - System Disabled.
	3-4	Reduced battery current limit: Link fitted - System enabled Link not fitted - System Disabled.
	1-2 & 5-6	Reduced battery current activated when reduced input current limit is active.
4	1-3	Temperature Compensation Calibration mode selected. (The remote temperature sensor <i>MUST</i> be removed before operation in this mode.)
	2-4	Temperature Compensation mode selected.
5	1-2	LED 4 illuminates at temperatures set by SOT R26 (i.e. Battery Over Temp Alarm).
	2-3	LED 4 illuminates when the Temperature Compensation system becomes active.
6	1-2	Temperature compensation enabled: This applies to a 6 pulse Rectifier logic board (part no. 4520049B) NOW OBSOLETE.
	2-3	Temperature compensation enabled. 12 pulse Rectifier Logic board (part no. 4520073 Z).
	No links	Temperature compensation disabled.

*Table 3 - Option board - Summary of link settings*





---

## 5. Chapter 5 - Maintenance

---

### 5.1 Introduction

---

This chapter contains the procedures necessary to effect general maintenance of the UPS module and battery. Certain procedures entail gaining internal access to the UPS, and should only be undertaken by a competent engineer who is familiar with the operation and layout of the equipment and understands the areas of potential hazard. If you have any doubts concerning safety or the method of carrying out any procedure then contact an approved service agent for assistance or advice. If the locally approved agent is not known to you, then you should contact the Customer Services & Support department at the address shown at the front of this manual. The manufacturer offers customer training, at a nominal fee, if required. Such training can range from a one-day operator course to in-depth training on maintenance and troubleshooting lasting several days, and can be carried out at the manufacturer's plant or at the customer premises.

### 5.2 Safety Precautions

---

When working on the UPS remember that the equipment contains live voltages at **ALL TIMES** unless it is *externally* isolated from the mains supply, bypass supply and batteries. It is essential that the safety and precautionary notes contained throughout this manual are read and **FULLY UNDERSTOOD** before touching any UPS internal component part.

### 5.3 Scheduled Maintenance

---

The UPS utilises solid-state components which are not subject to wear, with the only moving parts being the cooling fans. Scheduled maintenance requirements, beyond ensuring that the environmental conditions remain suitably cool and clean, are therefore minimal. However, a well documented periodic program of inspection and preventive maintenance, as suggested below, will help to ensure optimum equipment performance and may serve to detect certain minor malfunctions prior to them developing into a major fault.

#### 5.3.1 Daily checks

points:

Carry out a daily walk-by inspection of the UPS, checking the following

1. Carry out a spot check of the operator control panel; ensuring that all mimic LED indications are normal, all metered parameters are normal and no warning or alarm messages are present on the display panel.
2. Check for obvious signs of overheating.
3. Listen for any noticeable change in audible noise.
4. Ensure that the ventilation grills around the UPS are unobstructed.
5. If possible, log the results of the inspection, noting any discrepancies from the norm.



### 5.3.2 Weekly checks

Carry out the following checks from the mimic panel and log the results:

1. Measure and record the battery float charge voltage.
2. Measure and record the battery charge current.
3. Measure and record the UPS output voltage on all three phases.
4. Measure and record the UPS output line currents. If these are significantly different from the values previously logged then, if possible, record the size, type and location of any additional load connected to the UPS supply since the previous inspection. This type of information could prove useful to the troubleshooting engineer should a problem occur.

If any of the above indications differ greatly from the previously logged values for no apparent reason then you should contact the Customer Service & Support Department at the address given at the front of this manual for advice.

### 5.3.3 Annual Service

The equipment should be thoroughly cleaned and the following checks carried out annually. This entails working inside the equipment in regions containing hazardous voltages.

A manufacturer-trained engineer is fully aware of the hazards concerned and will carry out this procedure with the load connected to the maintenance bypass supply; however if the customer decides to carry out this service procedure himself it is imperative that the UPS be totally shut down and isolated from the input mains and bypass supplies and batteries using the procedure given below. We therefore strongly recommend that the annual service is carried out by trained personnel.

1. Carry out the weekly checks detailed above.
2. Shut down the UPS following the recommended operating procedure.
3. Isolate the UPS input mains supply externally (also the bypass supply if a split bypass system is in use) and isolate the battery.
4. Ensure that the UPS is totally powered down by checking for voltage at the mains input terminals, battery connection terminals, and output terminals (and bypass mains input terminals in a split bypass configuration).
5. Gain full access to the UPS interior by opening its internal hinged safety panel.

6. Carry out a thorough examination of the UPS power components and sub-assemblies, paying particular attention to the following:

*Electrolytic capacitors* - Check for signs of leakage, buckling etc.

*Magnetic components* - Check for signs of overheating, security of fixture and signs of delamination.

*Cables and connections* - Check cables for chaffing, fraying or signs of overheating. Check that all printed circuit board connectors are secure.

*Printed circuit boards* - check the cleanliness and integrity of the circuit boards and replace if any signs of deterioration are found.

7. Thoroughly clean inside the equipment enclosure using a vacuum cleaner and low pressure air to remove any foreign debris.
8. Reconnect the UPS input mains power.
9. Start the UPS and transfer the load to the inverter following the appropriate operating procedure.
10. If possible, check the battery autonomy time by opening the input isolator (I1) with the UPS on-load. Close the input isolator immediately the dc busbar voltage falls within 5 volts of the battery end of discharge voltage. (note For units operating at 380V a.c. the end of battery discharge is assumed when the battery voltage falls to 320 Vd.c. For units operating at 400V a.c. the end of discharge voltage is taken as 330 Vd.c. For units operating at 415V a.c. the end of discharge voltage is taken as 340 Vd.c. At these voltages the battery circuit breaker will trip and the load will power-down, unless a split bypass system is in use whereupon the load will transfer to bypass). Ensure that the available battery autonomy time meets the installation specifications.

#### 5.3.4 Extended service

We recommend that ALL the input/output power cables and their connections are checked periodically. As this requires the UPS to be *completely* shut down such a check should be carried out on an 'opportunity' basis but at an interval not exceeding 2 years.

#### 5.3.5 Battery maintenance

The batteries used with the UPS are generally of a sealed, valve-regulated type, and the only maintenance requirement is to ensure that the cells are kept clean and dry. Maintenance procedures appropriate to both valve-regulated and non-sealed batteries vary, and should be obtained from the battery manufacturer.





---

## 6. Chapter 6 - Troubleshooting

---

### 6.1 Troubleshooting UPS Systems

---

The UPS contains complex electronic control circuits that require a firm understanding in order to carry out comprehensive fault diagnosis and repair of the equipment. The following information aims to provide a trained user with sufficient knowledge to understand the nature of a fault through the correct interpretation of the accompanying alarms and indications, and to carry out any necessary first aid repair action.

#### **WARNING**

*Some of the instructions in the charts at the end of this chapter involve checking internal fuses. This should be undertaken (after the equipment has been shut down) only by a trained electrician who is familiar with the layout and operation of the equipment and fully conversant with the areas of potential hazard .*

#### 6.1.1 Operating parameters and limitations

There is no practical way of detecting an impending UPS malfunction. Most problems do not emerge as a gradual performance degradation; generally the UPS either works correctly or it will shut down - and transfer the load to the bypass supply if applicable. However, it is important to maintain a regular record of the UPS meter indications, as suggested in the maintenance instructions, in order that any change in the system or load characteristics are readily identified.

In general, the output voltage should be within 2% of nominal. If the UPS has not operated on battery power within the previous ten hours the battery charge current should be typically less than 6A.

If any indication differs significantly from the typical figures given above the cause should be investigated.

Information concerning prevailing load conditions can prove useful when discussing problems with the service agent - for example, details of any particular load being started or shed at the time that the fault occurred.

#### 6.1.2 General Troubleshooting Procedure

Troubleshooting should be carried out methodically using the following guidelines:

##### **Fault Identification**

When first summoned to the scene of a UPS fault, your immediate action should be to observe and record the displayed messages, mimic indications, meter indications and the position of the UPS power isolator switches. This should be completed before you touch any switch.

### Corrective Action

When all the indications have been noted, you should refer to the following fault interpretation charts and carry out the actions detailed against any led whose status is abnormal. If you are unsure as to how to undertake the actions detailed - or if several led indications are abnormal and you are unable to distinguish between the likely cause and affects - then seek immediate assistance from an approved service agent.

### Fault Reporting

Irrespective of whether fault rectification is successful or not, report the fault occurrence to the nearest service agent - who will then forward the details to the manufacturer. This type of customer feedback is an important factor in maintaining high product reliability, and also provides important data concerning the equipment field performance.

### Caution

*The following diagnostic charts are designed for 'first aid' troubleshooting only. If a problem cannot be resolved by taking the actions given then fully trained assistance should be sought immediately.*

*Do not under any circumstances make internal circuit adjustments or interfere with the circuit boards in any other way.*

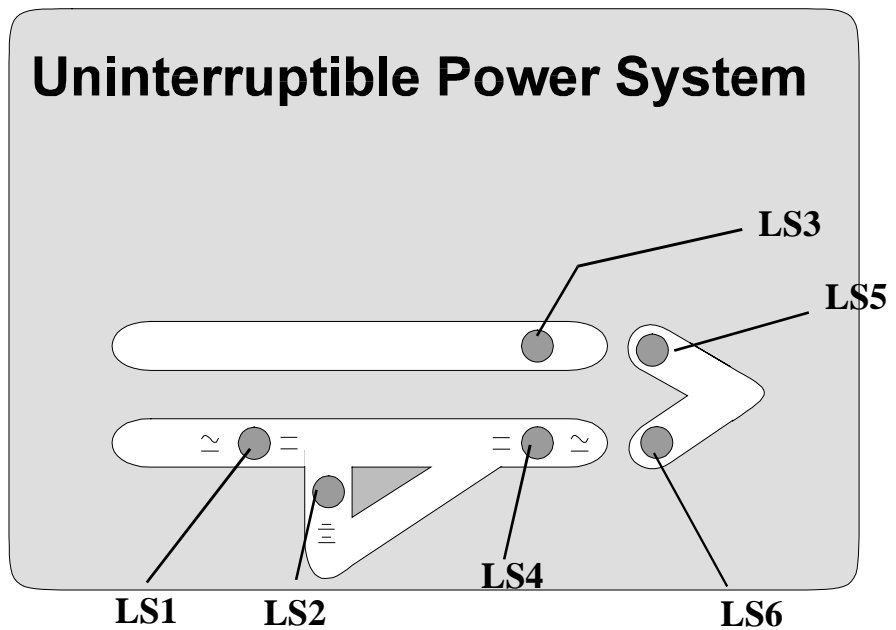

Figure 6-1 . Mimic pannel

LED NUMBER	NORMAL STATE	ACTIONS TO BE TAKEN IF ABNORMAL
LS1	ON	<p>If this led is OFF it signifies a problem either with the incoming mains supply or the rectifier section. See accompanying alarm messages.</p> <p>Check the following:</p> <ul style="list-style-type: none"> <li>a) Input isolator is closed.</li> <li>b) Input supply voltage is within 20% of nominal.</li> <li>c) Input fuses are OK.</li> <li>d) Power supply fuses are OK (Note: LS1 and LS2 on the AC Power Supply Board will be OFF if either of these fuses are ruptured).</li> <li>e) Mains sensing fuses on the High Voltage Interface board F4,F5,F6 are OK</li> <li>f) Check that slide switch I3 on the UPS Logic Board is closed.</li> <li>g) Phase rotation of the incoming supply and cables is correct</li> </ul> <p>If the above checks prove unsatisfactory then seek qualified assistance.</p>
LS2	ON	<p>If this led is OFF it signifies that either the battery circuit breaker is open or that the dc busbar voltage is below 320 Vdc.</p> <p><i>Note:</i> The dc busbar low voltage level is 330 Vdc for a 400V input supply and 340 Vdc for 415V input supply. The battery circuit breaker will open automatically if the dc voltage falls below these levels.</p> <p>Check the following:</p> <ul style="list-style-type: none"> <li>a) Battery circuit breaker is closed.</li> <li>b) DC busbar voltage - if not above 320V (330 Vdc for a 400V input supply and 340 Vdc for 415V input supply ) then carry out checks as per LS1 (mains failure) above. If the dc busbar voltage is greater than 320V(330 Vdc for a 400V input supply and 340 Vdc for 415V input supply ) but you are unable to close the battery circuit breaker then seek qualified assistance.</li> <li>c) If the battery circuit breaker trips as soon as mains power is disconnected then check the dc power supply fuses.</li> </ul>
LS3	ON	<p>If this led is OFF it signifies either that the bypass supply is not within acceptable tolerances or that the bypass supply isolator is open (in a split bypass system).</p> <p>Check that the bypass circuit breaker is closed, the supply is available and within specification, and phase rotation is correct.</p>
LS4	ON	<p>If this led is OFF it signifies that the inverter is not producing its correct output voltage.</p> <p>Check the following:</p> <ul style="list-style-type: none"> <li>a) If [OVER TEMPERATURE] OR [OVERLOAD] alarm messages are active then (after allowing the UPS to cool / checking that the load current on the bypass line is not excessive) press the reset switch (PS1) on the UPS Logic Board.</li> <li>b) Press the Inverter ON pushbutton on the mimic display.</li> <li>c) If the dc busbar is below 320V (330 Vdc for a 400V input supply and 340 Vdc for 415V input supply ) hen do checks as per LS1 above.</li> <li>d) Check that slide switch I2 is closed on the UPS Logic Board.</li> <li>e) If the inverter works OK when mains is available but not when mains is unavailable then check the dc power supply fuses.</li> </ul> <p>If the above checks prove unsatisfactory then seek qualified assistance.</p>
LS5**	OFF	<p>If this led is ON then it signifies that the load has been transferred to the static bypass supply and the output circuit breaker is closed. This indication should be mutually exclusive with LS6 described below - check out LS6 actions.</p>

LS6**	ON	If LS4 is also OFF then refer to LS4 checks. If LS6 is OFF but LS4 is ON then check the following: a) Ensure that the output circuit breaker is closed then press the Reset button (PS1) on the UPS Logic Board. b) Ensure that slide switch I1 on the Static Switch Logic Board is in the AUTO position. If the above checks prove unsatisfactory then seek qualified assistance.
-------	----	--

\*\*Note that in a *one-plus-one* system configured with a redundant module, it is possible for one of the two modules to shut down (due to a fault for example) without turning on its static switch. In a redundant module configuration, a module's static switch is disabled whenever its partnering module is on line. Therefore in the event of a fault you are likely to see LS4,5,6 all OFF.

## 6.2 Display panel message interpretation

The following table lists the various messages displayed on the operator panel together with a description of their interpretation.

<b>DISPLAY MESSAGES</b>	<b>INTERPRETATION</b>
EMERGENCY STOP ALARM	This alarm indicates that the UPS was shut down by means of the local or remote (if fitted) emergency stop pushbutton which of course is normally due to operator action - investigate why the emergency stop pushbutton was pressed. If the emergency stop pushbutton was not pressed then check the continuity of the remote emergency stop line (if fitted), and if no remote emergency stop line is fitted then check that a link is connected between terminals 4 and 5 of the UPS auxiliary terminal block.
INVERTER OFF OR FAILED ALARM	This alarm is active whenever the inverter is not producing its correct output voltage; either because it has been switched OFF or due to an internal fault.  The alarm will accompany other alarms such as [OVERLOAD], [LOAD ON BYPASS]
OVER TEMPERATURE ALARM	Over temperature is sensed by a normally-close thermostat (90°C operating) fitted to each inverter heat sink. If an over temperature condition arises, the audible alarm will accompany this message - the inverter stops and load transfers to bypass after 3 minutes.
OVERLOAD ALARM	The inverter overload has an inverse load/time characteristic - i.e. it will accept 125% overload for 10 minutes and 150% for 60 seconds. If this characteristic is exceeded then the load transfers to the bypass supply, the inverter stops and the overload alarm annunciates. The [OVERLOAD] alarm will annunciate at soon as the load exceeds 100% of the UPS rating, and the load will transfer to bypass some time later -depending on the degree of overload present.
BATTERY CB OPEN or BATTERY FUSE FAIL ALARM	This is a status indication only. Note that if the UPS is operating with the battery circuit breaker open and the mains power fails then the UPS output will also fail together with load power. Also check battery fuses.
OUTPUT CIRCUIT BREAKER OPEN ALARM	This is a status alarm. The output isolator must be selected 'CLOSED' at all times except when operating on the maintenance bypass supply.
RECTIFIER OFF OR FAILED ALARM	This alarm is active whenever the battery charger (rectifier) is not producing its correct output voltage; due to either an input supply failure, an internal fault, or an open input circuit breaker.
UPS ON MAINTENANCE BYPASS WARNING	This is a status warning that the load is being powered through the maintenance bypass line and is unprotected from mains supply abbreviations. Due to the fact that the UPS power supplies are fed by the input circuit breaker, this message will disappear if the input isolator is opened (and bypass isolator opened on a split bypass system) while the load is on the maintenance supply.

INVERTER UNSYNCHRONIZED WARNING	This warns that the inverter is not synchronised with the bypass supply, which is normally due to a problem with the bypass supply being outside an acceptable frequency window. Do not switch OFF the inverter when this alarm is active or the load will experience a 20 msecond power break.
BATTERY ON LOAD WARNING	This is a status warning that the battery is discharging. It normally accompanies a [MAINS FAILURE] or [RECTIFIER OFF OR FAILED] message.
MAINS FAILURE WARNING	MAINS FAILURE. Or mains supply out of specified acceptable range. Do not switch OFF the inverter while this indication is active or the load will lose its power.
BYPASS CB OPEN ALARM	This is a status alarm. The bypass isolator must be closed at all times
LOAD ON BYPASS WARNING	This is a status warning that the load is being powered through the static bypass line and is unprotected from mains supply aberrations.

*Note:* The dc busbar low voltage level is 330 Vdc for a 400V input supply and 340 Vdc for 415V input supply.

The battery circuit breaker will open automatically if the dc voltage falls below these levels.

Check the following:

b) DC busbar voltage - if not above 320V (330 Vdc for a 400V input supply and 340 Vdc for 415V input supply ) then carry out checks as per LS1 (mains failure) above. If the dc busbar voltage is greater than 320V(330 Vdc for a 400V input supply and 340 Vdc for 415V input supply) but you are unable to close the battery circuit breaker then seek qualified assistance.

c) If the dc busbar is below 320V (330 Vdc for a 400V input supply and 340 Vdc for 415V input supply) then do checks as per LS1 above.

7. Chapter 7 - SPECIFICATION

**SERIES 7400 UPS INDIVIDUAL MODULE SPECIFICATION**

**Note:** These specifications give the parameters for the standard 6 Pulse module and the 6 Pulse module with the 12 Pulse option fitted.

MECHANICAL CHARACTERISTICS	UNITS	Model kVA Rating									
		80		120		200		300		400	
		6 Pulse	12 Pulse	6 Pulse	12 Pulse	6 Pulse	12 Pulse	6 Pulse	12 Pulse	6 Pulse	12 Pulse
Height	mm	1 800				1900					
Width	mm	900	1300	1 250	1 650	1 400	1 900	2 460			
Depth	mm	800									
Weight	kg	750	950	1000	1200	1 350	1 750	2140	2650	2340	2850
Colour (two tone)	—	RAL 7035 (light grey) RAL 7016 (dark grey)									
Protection grade	—	With enclosure shut — IP20 With front door open — IP20									
Ventilation	—	by internal intake fans									
Airflow	m <sup>3</sup> /h	1800	2150	2600	2950	4400	4750	6160	6160	8820	8820
Cable entry	—	Bottom or either side						Top or Bottom			
<b>ENVIRONMENTAL</b>											
Operating temperature	°C	0 — 40									
Maximum temperature for 8 hr day	—	40 °C derate by 1,5% per °C between 40° C — 50° C									
Mean temperature for 24 hr day	°C	35 max									
Relative humidity	—	≤ 90% at 20°C									
Altitude		≤ 1000m asl (derate by 1% per 100m between 1000 and 2000m)									
Storage temperature	°C	-25 to +70									

INPUT RATINGS	UNITS	Model kVA Rating									
		80		120		200		300		400	
		6 Pulse	12 Pulse	6 Pulse	12 Pulse	6 Pulse	12 Pulse	6 Pulse	12 Pulse	6 Pulse	12 Pulse
Power consumption at rated load while float charging the battery	kVA	87	84	129	125	216	206	320	309	428	412
Power consumption at rated load while boost charging the battery	kVA	109	104	161	156	270	257	401	386	534	514
Input current level normal running (380V)	A	134	127	202	190	330	313	486	463	646	615
Input current level full battery recharge (380V)	A	167	158	251	237	412	390	609	579	808	769
Line voltage	V a.c.	380 - 415 3Ph									
Permissible input voltage variation	%	+10 -15									
Frequency	Hz	50 or 60									
Permissible input voltage variation	%	± 5									
Power walk-in	—	Progressive over 10 seconds									
Power factor at rated voltage and load	cos $\Phi$	0,8	0,84	0,8	0,84	0,8	0,84	0,8	0,84	0,8	0,84
with optional input filter fitted (only 6p)		>0,9									
<b>SYSTEM DATA</b>											
Efficiency at 50% load	%	92,5	91,3	92,8	91,6	93,0	91,8	94,1	93,1	94,0	93,5
Efficiency at 100% load	%	92,0	90,2	92,8	90,6	92,8	91,5	93,4	92,5	93,3	92,5
Losses at rated load	kW	5,8	6,9	7,5	10	12,4	14,9	17,0	19,5	22,2	25,9
Losses with battery on boost charge	kW	6,1	7,3	8,1	10,6	13,5	15,8	18,5	21	24,4	27,9
Losses with no load	kW	1,8	1,8	2,5	2,5	4,0	4,0	4,8	6	6	7
Acoustic noise at rated load. (1 metre from the apparatus according to ISO3746)	dB(A)	63		63		68	70	69	71	71	73

OUTPUT RATINGS	UNITS	Model kVA Rating									
		80		120		200		300		400	
		6 Pulse	12 Pulse	6 Pulse	12 Pulse	6 Pulse	12 Pulse	6 Pulse	12 Pulse	6 Pulse	12 Pulse
Voltage	V a.c.	380/400/415 (preset on commissioning) 3 Ph N									
Frequency	Hz	50 or 60 (presettable)									
Power at 0,8pf	kVA	80	120	200	300	400					
Power at 1,0pf	kW	64	96	160	240	320					
Overload ability at 0,8pf 3 Ø  1 Ø	—	110% for 60 minutes 125% for 10 minutes 150% for 1 minute 200% for 30 seconds									
Current limiting short circuit (inverter) 150% rated current (3 phase) for 220% rated current (1 phase) for	—	< 5 seconds < 5 seconds									
Maximum permissible non linear load	%	100 with 3:1 crest factor									
Voltage stability — steady state	—	± 1%									
Voltage stability — transient state	—	± 5%									
Reset time to within ± 1%	—	20 ms									
Frequency stability — synchronised	—	The output will synchronise with the input supply within ±1 Hz of nominal frequency (adjustable to ±2 Hz)									
Frequency stability — unsynchronised	—	± 0,1% when the input supply frequency is outside the synchronising range									
Phase voltage asymmetry — balanced load	—	± 1%									
Phase voltage dissymmetry —100% unbalanced load	—	± 2 %									
Voltage phase shift with balanced load	Angle°	120 ± 1									

OUTPUT RATINGS	UNITS	Model kVA Rating									
		80		120		200		300		400	
		6 Pulse	12 Pulse	6 Pulse	12 Pulse	6 Pulse	12 Pulse	6 Pulse	12 Pulse	6 Pulse	12 Pulse
Voltage phase shift — with unbalanced load	Angle°	120 ± 1									
Output voltage distortion — linear load	—	1% typical 2% max									
Output voltage distortion — non-linear load (3:1 crest factor)	—	≤ 5% max									
Maximum frequency slew rate	Hz/sec	0,1									
Synchronised transfer to bypass	ms	0 approximately									
Unsynchronised transfer to bypass	ms	20 approximately									

INTERMEDIATE DC CIRCUIT	UNITS	Model kVA Rating									
		80		120		200		300		400	
		6 Pulse	12 Pulse	6 Pulse	12 Pulse	6 Pulse	12 Pulse	6 Pulse	12 Pulse	6 Pulse	12 Pulse
Voltage limits of inverter operation	Vdc	320									
minimum		320									
maximum		500									
Number of lead-acid cells	UPS 380 V	192									
	UPS 400 V	198									
	UPS 415 V	204									
Float charge voltage	UPS 380 V	432									
	UPS 400 V	446									
	UPS 415 V	459									
Boost charge voltage	UPS 380 V	460									
	UPS 400 V	475									
	UPS 415 V	490									
End of discharge voltage	UPS 380 V	320									
	UPS 400 V	330									
	UPS 415 V	340									
Absolute maximum voltage (manual charge)	UPS 380 V	480									
	UPS 400 V	495									
	UPS 415 V	500									

INTERMEDIATE DC CIRCUIT	UNITS	Model kVA Rating									
		80		120		200		300		400	
		6 Pulse	12 Pulse	6 Pulse	12 Pulse	6 Pulse	12 Pulse	6 Pulse	12 Pulse	6 Pulse	12 Pulse
Voltage stability with rectifier	—	± 1%									
Residual alternating voltage	—	≤ 1%									
Battery charging cycle	—	Characteristics to DIN 41772 I-U, boost-to-floating charge switching, with current measuring criterion plus control of charging time									
Maximum boost charge duration	hours	1 to 15 selectable in 1 hr steps									
Charging current	A	8-40		10-60		20-100		30- 150		40-200	
Power consumption at rated load	kW	69		102		171		253		337	
Input current to inverter at minimum voltage	A	209		309		517		791		1059	
Efficiency of inverter + static switch @50% load	%	94		94,2		94,4		95,5		95,0	
Efficiency of inverter + static switch @100% load	%	93,4		94,0		94,0		94,8		94,5	
<b>STATIC SWITCH CIRCUIT</b>											
Overload from standby mains	A	14,3 times rated current for 10 mS 12,6 times rated current for 20mS 11,0 times rated current for 50mS 10,0 times rated current for 100mS 9,0 times rated current for 200mS 8,0 times rated current for 500mS 7,1 times rated current for 1 Second 6.6 times rated current for 2 Seconds 5,7 times rated current for 5 Seconds									
Current rating of neutral cable	A	1,5 times rated current									rated current

## BATTERY CABINETS

<b>MECHANICAL CHARACTERISTICS</b>	<b>UNITS</b>	<b>860 mm Cabinet</b>
Dimensions (W X D X H)	mm	860 X 800 X 1800
Weight (without batteries)	kg	140
Battery circuit breaker size	Amps	250
Ventilation	—	Natural
Lifting	—	Top (via eyes) or bottom (trans-pallet entry)
<b>BATTERY CIRCUIT BREAKER BOX</b>	<b>N° of Poles</b>	<b>Suitable for UPS size (kVA)</b>
250 A	3	80 - 120
400 A	4	120
630 A	4	200
800 A	4	300
1000 A	4	400
Undervoltage trip coil rating all units	—	110Vdc (6,7 — 9,2 kOhms)
Auxiliary contacts (for signalling) all units	—	1 set changeover

