

Liebert® APM

User Manual – 30 - 150kW, Single Module and Parallel System



This Manual Involves The Following Parts And Components.

Part	Part Number	Remark
LIEBERT APM UPS	APMxxxabcd00	xxx; y, a, b, c, d according to ratings/options
Modular Battery Cabinet	APMMOBACAB	
Battery Module	APMBATMODF	
Battery temperature sensor (for external battery)	APMA0UFXBTS	
Parallel or Dual Bus control cable (5, 10, and 15m)	APMPRDBC05	Classified according to length (m)
SNMP Card	IS-WEHLB	
RS485 Card	IS-485L	
Relay card	RELAYCARD-NX	
Battery Circuit breaker Control Board	N/A	

Safety Precautions

This manual contains information concerning the installation and operation of Emerson LIEBERT APM UPS . Please carefully read this manual prior to installation.

The LIEBERT APM UPS cannot be put into operation until it is commissioned by engineers approved by the manufacturer (or its agent).. Not doing so could result in personnel safety risk, equipment malfunction and invalidation of warranty.

The UPS has been designed for commercial or industrial use only, and is not intended for use in any life support application.

This is a CLASS A Uninterruptible Power Supply (UPS) product. In a domestic environment, this product may cause radio interference, in which case, the user may be required to take additional measures.



Conformity and standards

This product complies with CE73/23 & 93/68 (low voltage safety) and 89/336 (EMC), and EMC standards of Australia and New Zealand (C-Tick), and the following UPS product standards:

*IEC62040-1-1-General and safety requirements for use in operator access area

*IEC/EN62040-2 EMC requirements CLASS A

*IEC62040-3 Performance requirements and test methods

For more details, refer to Chapter 9 .

Continued compliance requires installation in accordance with these instructions and the use of manufacturer approved accessories only.



WARNING: high earth leakage current

Earth connection is critical before connecting the input supply (include both utility supply and battery).

"Earth leakage current introduced by the UPS, in any configuration from 30kW to 150kW, exceeds 3.5 mA and is less than 1000 mA and complies with the requirements of IEC/EN 62040-1 / IEC/EN 60950-1" Transient and steady-state earth leakage currents, which may occur when starting the equipment, should be taken into account when selecting instantaneous RCCB or RCD devices.

Residual Current Circuit Breakers (RCCBs) must be selected sensitive to DC unidirectional pulses (class A) and insensitive to transient current pulses.

Note also that the earth leakage currents of the load will be carried by this RCCB or RCD.

This equipment must be earthed in accordance with local electrical authority codes of practice.



WARNING: backfeeding protection

This system has a control signal available for use with an automatic device, externally located, to protect against backfeeding voltage through the mains Static Bypass circuit.If this protection is not used with the switchgear that is used to isolate the bypass circuit, a label must be added to the switchgear to advise service personnel that the circuit is connected to a UPS system.

The text has the following meaning or is equivalent to: Isolate the UPS before working on the circuit of this UPS.



Components that can be maintained by user

All the equipment maintenance and servicing procedures involving internal access need special tools and should be carried out only by trained personnel. The components that can only be accessed by opening the protective cover with tools cannot be maintained by user.

This UPS full complies with "IEC62040-1-1-General and safety requirements for use in operator access area UPS". Dangerous voltages are present within the battery box. However, the risk of contact with these high voltages is minimized for non-service personnel. Since the component with dangerous voltage can only be touched by opening the protective cover with a tool, the possibility of touching high voltage component is minimized. No risk exists to any personnel when operating the equipment in the normal manner, following the recommended operating procedures in this manual.



Battery voltage higher than 400Vdc

All the battery maintenance and servicing procedures involving internal access need special tools or keys and should be carried out only by trained personnel.

SPECIAL CARE SHOULD BE TAKEN WHEN WORKING WITH THE BATTERIES ASSOCIATED WITH THIS EQUIPMENT. WHEN CONNECTED TOGETHER, THE BATTERY TERMINAL VOLTAGE WILL EXCEED 400Vdc AND IS POTENTIALLY LEATHAL.

Battery manufacturers supply details of the necessary precautions to be observed when working on, or in the vicinity of, a large bank of battery cells. These precautions should be followed implicitly at all times. Particular attention should be paid to the recommendations concerning local environmental conditions and the provision of protective clothing, first aid and fire-fighting facilities.

Contents

Chapter 1 Installation	6
1.1 Introduction	6
1.2 Initial Checking.....	6
1.3 Location	6
1.3.1 UPS Location.....	6
1.3.2 External Battery Room.....	7
1.3.3 Storing	7
1.4 Positioning	7
1.4.1 System Cabinet	8
1.4.2 Mooving The Cabinets.....	8
1.4.3 Transporting The Cabinets	8
1.4.4 Clearances Required For Operating.....	8
1.4.5 Front Access.....	8
1.4.6 Final Positioning	8
1.4.7 Installation Of Adjustable Feet.....	8
1.4.8 UPS Composition	9
1.4.9 Installing Power Modules and Battery Modules	9
1.4.10 Cable Entry.....	11
1.5 External Protective Devices	12
1.5.1 Rectifier And Bypass Input Supply Of The UPS	12
1.5.2 External Battery	12
1.5.3 UPS Output	12
1.6 Power Cables.....	13
1.6.1 Cable Connections	14
1.7 Control Cabling And Communication	15
1.7.1 UPS Dry Contact And Parallel Signal Board X2 Features	15
1.7.2 Input Dry Contact Interface.....	15
1.7.3 External Battery Circuit Breaker Interface.....	16
1.7.4 External Maintenance Bypass Cabinet	16
1.7.5 Output Dry Contact Interface	17
1.7.6 EPO Input Port	17
1.7.7 Battery temperature sensor	18
1.7.8 Other Interfaces.....	18
Chapter 2 Battery Installation	19
2.1 General Recommendations	19
2.2 LIEBERT APM Battery typologies.....	20
2.3 Safety.....	20

2.3.1 Modular Battery Cabinet.....	20
2.3.2 Battery Installation.....	21
2.4 Battery maintenance.....	22
Chapter 3 Installation Of UPS Rack System And Parallel System.....	23
3.1 Overview.....	23
3.2 UPS Rack Modules In Parallel System.....	23
3.2.1 Installation Of Cabinet.....	23
3.2.2 External Protective Devices.....	24
3.2.3 Power Cables.....	24
3.2.4 Control Cables.....	24
3.3 Dual-Bus System.....	24
3.3.1 Installation Of Cabinet.....	24
3.3.2 External Protective Devices.....	25
3.3.3 Power Cables.....	25
3.3.4 Control Cables.....	25
Chapter 4 Installation Drawing.....	26
4.1 Internal Battery Module.....	33
4.1.1 Appearance Of Internal Battery Module.....	33
Chapter 5 Operations.....	35
5.1 Introduction.....	35
5.1.1 Split-Bypass Input.....	36
5.1.2 Static Transfer Switch.....	36
5.2 1+N Parallel System.....	36
5.2.1 Features Of Parallel System.....	36
5.2.2 Parallel Requirements Of UPS Modules.....	36
5.3 Operating Mode.....	37
5.3.1 Normal Mode.....	37
5.3.2 Battery Mode.....	37
5.3.3 Auto-Restart Mode.....	37
5.3.4 Bypass Mode.....	37
5.3.5 Black Start Mode.....	38
5.3.6 Maintenance Mode (Manual Bypass).....	38
5.3.7 Parallel Redundancy Mode (System Expansion).....	38
5.3.1 Sleep Mode.....	38
5.4 Battery Management—Set During Commissioning.....	39
5.4.1 Normal Function.....	39
5.4.2 Advanced Functions (Software Settings Performed By The Commissioning Engineer).....	39
5.5 Battery Protection (Settings By Commissioning Engineer).....	39
Chapter 6 Operating Instructions.....	40
6.1 Introduction.....	40

6.1.1 Power Switches	40
6.2 UPS Startup	40
6.2.1 Start-Up Procedure.....	40
6.2.2 Procedures For Switching Between Operation Modes	41
6.3 Battery Start.....	41
6.4 Procedure For Switching The UPS Into A Maintenance Bypass From Normal Mode	42
6.5 Procedure For Completely Powering Down A UPS	42
6.6 EPO Procedure.....	42
6.7 Auto Start.....	43
6.8 UPS Reset Procedure.....	43
6.9 Operation Instruction For Power Module Maintenance	43
6.10 Language Selection	44
6.11 Changing The Current Date And Time.....	45
6.12 Control Password.....	45
Chapter 7 Operator Control And Display Panel.....	46
7.1 Introduction	46
7.1.1 Mimic Current Path	46
7.1.2 Audible Alarm (Buzzer).....	47
7.1.3 Functional Keys	47
7.1.4 LCD And Menu Buttons	47
7.1.5 Detailed Description Of Menu Items	49
7.2 UPS Event And Alarm List	51
7.3 Prompt Window.....	54
7.4 Default Screen	55
Chapter 8 Optional Parts.....	56
8.1 Battery Ground Fault Detection Set	56
8.2 Replacing Dust Filters.....	57
Chapter 9 Product Specifications	58
9.1 CONFORMITY AND STANDARDS	58
Appendix 1 Information for the protection of the Environment.....	62

Table of figures

Fig. 1-1: UPS Structure	9
Fig. 1-2: Installing Power Modules	10
Fig. 1-3: The symbols of RCCB	12
Fig. 1-4: Bypass Module (include Interfaces of dry contact and parallel signal board X2)	15
Fig. 1-5: Input dry contact interface.....	16
Fig. 1-6: Connections of output dry relay contacts and EPO.....	17
Fig. 1-7: A single battery temperature sensor and monitoring board.....	18
Fig. 2-1: Battery Box Back.....	20
Fig. 3-1: Circuit ram of emergency power off.....	23
Fig. 3-2: Connection of parallel control cables of “1+N” system.....	24
Fig. 3-3: Typical dual bus system (with static bypass switch LBS).....	25
Fig. 3-4: Typical dual bus system (with LBS) consisting of two 1+1 parallel system.....	25
Fig. 4-1: Signal Wiring Diagram	26
Fig. 4-1: External Battery Connections	27
Fig. 4-2: 150kVA UPS module system, front view whit open door and back view without doors.....	28
Fig. 4-3: Modular Battery Cabinet: front view with open door and back view without doors.....	28
Fig. 4-4: UPS External dimensions	29
Fig. 4-5: Battery Cabinet External dimensions	30
Fig. 4-6: UPS and BC bottom view show the position of casters and fixing holes	30
Fig. 4-7: UPS and BC bottom view show the cable entry area.....	30
Fig. 4-8: UPS and BC top view with open doors.....	31
Fig. 4-9: AC and DC Connection.....	31
Fig. 4-10: AC And DC Connection details	32
Fig. 4-11: Power Module	33
Fig. 4-12: Static Bypass Module.....	33
Fig. 4-13: Battery Module	34
Fig. 5-1: Single unit block diagram.....	35
Fig. 6-1: Location of battery start button	41
Fig. 7-1: UPS operator control and display panel	46
Fig. 7-2: Sections of the LCD and menu buttons.....	48
Fig. 7-3: Menu tree structure.....	49
Fig. 7-4: Default screen	55
Fig. 8-1: Wiring of battery ground fault detection set.....	56
Fig. 8-2: Replacing Air Filters	57

Table Of Tables

Tab. 1-1: UPS configuration list.....	9
Tab. 1-2: DIP switch setting method.....	10
Tab. 1-3 Maximum steady state AC and DC Current.....	13
Tab. 1-4: Distances from floor to connection points.....	14
Tab. 1-5: Description of dry contact input port.....	16
Tab. 1-6: External battery circuit breaker interface.....	16
Tab. 1-7: External maintenance bypass cabinet Interface.....	16
Tab. 1-8: Relay dry contact output port.....	17
Tab. 1-9: EPO input dry contact relay.....	17
Tab. 6-1 UPS Operating mode.....	40
Tab. 7-1: Descriptions of UPS operator control and display panel.....	46
Tab. 7-2: Status description of rectifier indicator (1).....	46
Tab. 7-3: Status description of bypass indicator (2).....	47
Tab. 7-4: Status description of bypass indicator (3).....	47
Tab. 7-5: Status description of inverter indicator (4).....	47
Tab. 7-6: Status description of load indicator (5).....	47
Tab. 7-7: Status description of status (alarm) indicator (6).....	47
Tab. 7-8: Audible alarms descriptions.....	47
Tab. 7-9: Functional keys Description.....	47
Tab. 7-10: Icons of functional keys and the meanings.....	48
Tab. 7-11: UPS information window Items description.....	49
Tab. 7-12: UPS menu and data window Item description.....	50
Tab. 7-13: UPS event log.....	54
Tab. 7-14: Prompt window and meanings.....	54
Tab. 8-1: Dry contact fault alarm signal is available for remote monitoring.....	56
Tab. 9-1: Compliance with European, international standards.....	58
Tab. 9-2: Environmental parameters.....	58
Tab. 9-3: AC/AC Efficiency, Loss and Air Exchange.....	58
Tab. 9-4: UPS mechanical characteristics.....	59
Tab. 9-5: Rectifier AC input (Utility).....	59
Tab. 9-6: Intermediate DC circuit.....	60
Tab. 9-7: Inverter output to critical load.....	60
Tab. 9-8: Bypass input.....	61

Chapter 1 Installation

1.1 Introduction

This chapter introduces the relevant requirements for positioning and cabling of the LIEBERT APM UPS Rack Module and related equipment.

Because each site has its requirements, it is not the aim of this chapter to provide step-by-step installation instructions, but to act as a guide for the general procedures and practices that should be observed by the installing engineer.



Warning: installation can only be done by authorized engineers

Do not apply electrical power to the UPS equipment before the commissioning engineer arrives at installation site. The UPS should be installed by a qualified engineer in accordance with the information contained in this chapter. All the equipment not referred to in this manual is shipped with details of its own mechanical and electrical installation information.



Note: 3-Phase 4-Wire Input Power is required

The standard LIEBERT APM UPS system of Emerson can be connected to TN, TT and IT AC distribution system (IEC60364-3) of 3-phase 4-wire, and a 3-wire to 4-wire conversion transformer is provided as an optional part. If the system is connected to IT AC distribution system, its input needs to be fitted with a 4-pole circuit breaker in accordance with relevant IT system standard.



WARNING: battery hazards

SPECIAL CARE SHOULD BE TAKEN WHEN WORKING WITH THE BATTERIES ASSOCIATED WITH THIS EQUIPMENT.

When connecting the battery, the battery terminal voltage will exceed 400Vdc and is potentially lethal.

Eye protection should be worn to prevent injury from accidental electrical arcs.

Remove rings, watches and all metal objects.

Only use tools with insulated handles.

Wear rubber gloves.

If a battery leaks electrolyte, or is otherwise physically damaged, it must be replaced, stored in a container resistant to sulfuric acid and disposed of in accordance with local regulations.

If electrolyte comes into contact with the skin, the affected area should be washed immediately with water.

1.2 Initial Checking

Perform the following checking operations prior to the UPS installation.

1. Visually examine if there is any damage inside and outside the UPS rack and battery equipment due to the transportation. Report any such damage to the shipper immediately.
2. Verify the product label and confirm the correctness of the equipment. The equipment label is attached on the back of front door. The UPS model, capacity and main parameters are marked on the label.

1.3 Location

1.3.1 UPS Location

The UPS is intended for indoor installation and should be located in a cool, dry and clean environment with adequate ventilation to keep the environmental parameters within the specified operating range (see Tab. 9-2).

The LIEBERT APM series UPS uses forced convection cooling by internal fans. Cooling air enters the module through ventilation grills located at the front part of the cabinet and exhausted through grills located in the rear part of the cabinet. Please do not block the ventilation holes.

If necessary, a system of extractor fans should be installed to aid cooling-air flow. An air filter should be used when the UPS is to operate in a dirty environment and should be regularly cleaned to maintain airflow.

The cooling capacity of air conditioner should be selected according to the power loss data of UPS specified in Tab. 9-3: Normal mode (VFI SS 111 double-conversion UPS)

Note: The UPS should be installed on a cement surface or other surface that is not combustible.

1.3.2 External Battery Room

The battery will generate some amount of hydrogen and oxygen at the end of charging, so the fresh air volume of the battery installation environment must meet EN50272-2001 requirements.

The ambient temperature of the battery must be stable. Ambient temperature is a major factor in determining the battery capacity and life. The nominal operating temperature of battery is 20°C. Operating above this temperature will reduce the battery life, and operation below this temperature will reduce the battery capacity. If the average operating temperature of battery is increased from 20°C to 30°C, then the service life of the battery will be reduced by 50%. If the operating temperature of the battery is above 40°C, then the battery service life will be decreased in exponent rate. In a normal installation, the battery temperature is maintained between 15°C and 25°C. Keep batteries away from heat sources or air outlets.

If external batteries are to be used, the battery circuit breakers (or fuses) must be mounted as close as possible to the batteries, and the connecting cables should be as short as possible.

1.3.3 Storing

Should the equipment not be installed immediately, it must be stored in a room so as to protect it against excessive humidity and heat sources (see Tab. 9-2). The battery needs to be stored in dry and cool place with good ventilation. The most suitable storage temperature is 20 °C to 25°C.



Preventing battery deep discharge

Should the UPS remains unpowered for a prolonged period of time while the battery are connected, the batteries may deeply discharge and being so permanently damaged .In such cases it is therefore recommended to leave the battery circuit breaker(s) open. During storage in any case, periodically charge the battery according to the battery user manuals.

1.4 Positioning

When the equipment has been finally positioned, ensure the UPS will remain stationary and stable. To prolong the service life, the place chosen must guarantee:

- Space for easy operation on the UPS
- Air sufficient enough to dispel heat produced by UPS
- Against atmospheric agents
- Against excessive humidity and heat sources
- Against dust
- With the current fire prevention requirements
- The operating environment temperature is within +20°C to +25°C. The batteries are at maximum efficiency in this temperature range (for information about the battery storage and transportation as well as the environment, refer to Table 8-2)

This equipment is of steel frame structure wrapped by removable panels. The top and side panels are fixed by screws.

After opening the UPS rack door, the auxiliary connections for external low voltage interface and the maintenance bypass can be accessed. The UPS rack has an operator and control panel located on its front door, which provides the basic operating status and alarm information. Batteries are external. The UPS provides air inlet port in the front and the air exhaust port in the rear part.

1.4.1 System Cabinet

A UPS system can comprise an UPS rack system, external battery cabinet, depending on the specific system requirement.

All the UPS system cabinets used in the same installation site are of the same height and should be positioned side-by-side to achieve an aesthetically appealing effect.

Refer to Chapter 7 Installation Drawing for the positioning of UPS cabinet.

1.4.2 Moving The Cabinets



Warning

Ensure that any lifting equipment used in moving the UPS cabinet has sufficient lifting capacity. The UPS is fitted with castors – take care to prevent movement when unbolting the equipment from its shipping pallet. Ensure adequate personnel and lifting aids are available when removing the shipping pallet.

Ensure that the UPS weight is within the weight loading capacity range of any hoisting equipment. See *Tab. 1-1* for UPS weight.

UPS and optional cabinets can be handled by means of a fork lift or similar equipment. The UPS cabinet can also be moved by its castors when moving in a short distance.

Note: Care must be taken when handling units fitted with batteries. Keep such moves to a minimum.

1.4.3 Transporting The Cabinets

Note :

The unit can be shipped with 1, 2 or 3 power modules installed but not with 4 or 5 (to be shipped separately), and cannot be with any battery modules installed

1.4.4 Clearances Required For Operating

As LIEBERT APM series UPS has no ventilation grills at either sides, no clearances are required for the sides.

To enable routine tightening of power terminations within the UPS, it is recommended that clearance around the front of the equipment should be sufficient to enable free passage of personnel with the doors fully opened. It is important to leave a distance of 150mm in the rear side of the rack to permit adequate circulation of air coming out of the unit.

If the UPS make use of internal modular battery sufficient clearing shall be given at the back site to allow personnel to operate the battery circuit breakers

1.4.5 Front Access

The component layout of the UPS rack system supports front access and repairing the UPS, thus reducing the space requirement for side and rear access.

1.4.6 Final Positioning

When the equipment has been finally positioned, ensure the adjustable feet are set so that the UPS will remain stationary and stable.

1.4.7 Installation Of Adjustable Feet

Installation diagrams in Chapter 4 of this manual identify the location of the holes in the base plate through which the equipment can be bolted to the floor. If the UPS is to be located on a raised floor, it should be mounted on a

pedestal suitably designed to accept the UPS point loading (more than 1000 kg). Refer to the bottom view in Fig. 4-7 to design this pedestal and stable.

1.4.8 UPS Composition

The UPS structure is shown in Fig. 1-1 The UPS configuration is provided in Tab. 1-1

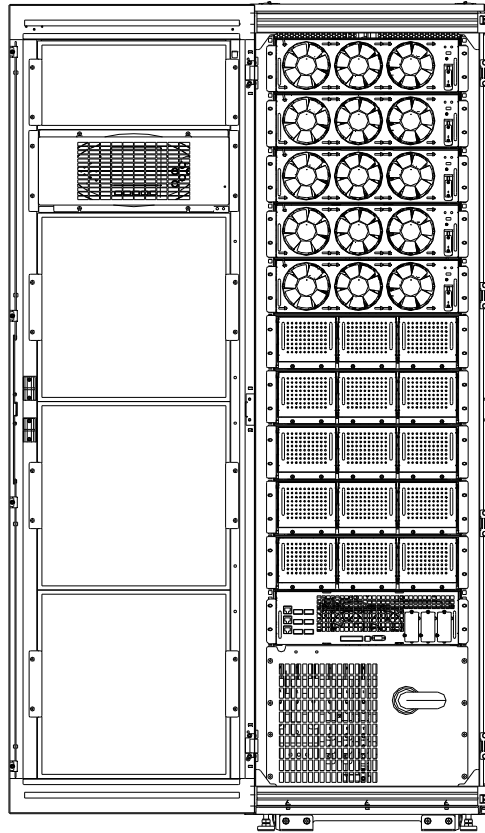

Fig. 1-1: UPS Structure

Item	Component	Quantity	Remarks
1	System Display	1	Requisite, factory installed
2	Maintenance Bypass	1	Requisite, factory installed
3	Static Bypass module	1	Requisite, factory installed
4	Power module	$1 \leq n \leq 5$	Requisite, factory installed if $n \leq 3$; 4 th and 5 th module installed at site
5	Battery module	$0 \sim 10-n$	Optional, installed at site

Tab. 1-1: UPS configuration list

1.4.9 Installing Power Modules and Battery Modules

The number and possible installation positions of the Power Modules and Battery Modules may vary according to the chosen factory configuration. Thanks to the different mounting depth it's not possible to install a power module instead of a battery module and vice versa.

Please install the power modules and Battery modules from bottom to top, so as to avoid cabinet toppling due to high gravity center.

Installation procedures of power modules

When installing power modules always work from the lower available space upwards to prevent raising the center of gravity.

1. Use the DIP switch on the front panel of the module to set the module address. The setting range is from 1 to 5. The module address should be exclusive. The setting method is shown in *Tab. 1-2*

Bit 1	Bit 2	Bit 3	Bit 4	Bit 5	Module address
1	0	0	0	0	1
0	1	0	0	0	2
1	1	0	0	0	3
0	0	1	0	0	4
1	0	1	0	0	5

Tab. 1-2: DIP switch setting method

2. Place the ready switch on the front panel of the module to the up position (i.e., in unready state).
3. Insert the module in the installation position, and push it into the cabinet.
4. Secure the module to the cabinet through the fixing holes on both sides of the front panel of the module.
5. Place the ready switch to the down position (i.e., in ready state).

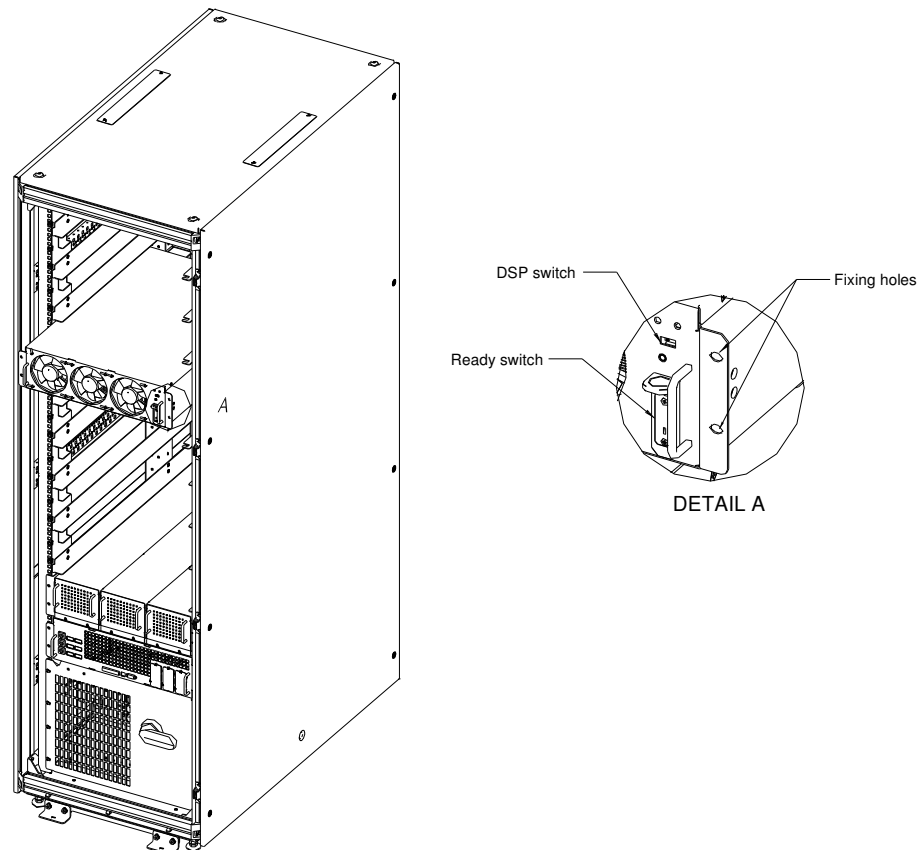

Fig. 1-2: Installing Power Modules

Installation procedures of Battery Modules

When installing battery modules always work from the lower available space upwards to prevent raising the center of gravity.

1. Open the front door
2. Insert the module in the installation position, and push it into the cabinet.
3. Secure the module to the cabinet through the fixing holes on both side of the front panel of the module

1.4.10 Cable Entry

Cables can enter the LIEBERT APM series UPS rack system and battery cabinet from below. Cable entry is made possible through a blanking plate fitted at the bottom of the equipment. The recommended installation practice is to install glands to prevent foreign material or vermin entering the cabinet.

1.5 External Protective Devices

For safety concerns, it is necessary to install external circuit breakers or other protective devices for the input AC supply of the UPS system. This section provides generic practical information for qualified installation engineers. The installation engineers should have the knowledge of the regulatory wiring standards, and of the equipment to be installed.

1.5.1 Rectifier And Bypass Input Supply Of The UPS

Over currents

Install suitable protective devices in the distribution unit of the incoming mains supply, considering the power cable current-carrying capacity and overload capacity of the system (see Tab. 9-7). Generally, the magnetic circuit breaker with IEC60947-2 tripping curve C (normal) at the 125% of the current listed in Tab. 9-7 is recommended.

Split bypass: In case a split bypass is used, separate protective devices should be installed for the rectifier input and bypass input in the incoming mains distribution panel.

Note: The rectifier input and bypass input must use the same neutral line.

 Note
For IT power network system, 4-pole protective device must be installed on the external input distribution and external output distribution of the UPS.

Protection against earth faults (RCD devices):

The RCD device installed upstream of the input supply should:

- Sensitive to DC unidirectional pulses (class A) in the network
- Insensitive to transient current pulses
- Have an average sensitivity that is adjustable between 0.3A and 1A.

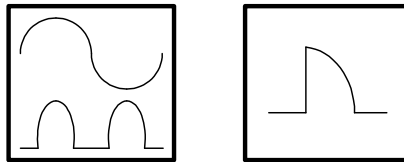

Fig. 1-3: The symbols of RCCB

When using the RCD in the split bypass system or parallel system, the RCD should be installed in the upstream of the input distribution to avoid wrong alarm.

The residual current introduced by RFI filter in the UPS is between 3.5mA and 1000mA. It is recommended to confirm the sensitivity of each RCD of upstream input distribution and downstream distribution (to load).

1.5.2 External Battery

The DC compatible circuit breaker provides over current protection for UPS system and battery, which is provided by the external battery cabinet. See Appendix A for a selection guide

1.5.3 UPS Output

In the eventuality that an external distribution panel is used for load distribution, the selection of protective devices must provide discrimination with those that are used at the input to the UPS (see Tab. 9-7).

1.6 Power Cables

Design the cables according to the descriptions in this section and local regulatory wiring standards, and the environmental conditions (temperature and physical support media) should be taken into consideration. Refer to IEC60950-1 Table 3B Cabling.

 Warning
FAILURE TO FOLLOW ADEQUATE EARTHING PROCEDURES CAN RESULT IN EMI, ELECTRIC SHOCK HAZARD, OR RISK OF FIRE, SHOULD AN EARTH FAULT OCCUR.

UPS power (kVA)	Rated current (A)									Busbar stud size			
	Mains input current at full load battery charging ^{1,2}			Output current at full load ²			Battery discharging current at E.O.D =1.67V , no overload			Input /Output/ Bypass cables		External Battery Cable (bolt)	Torque (Nm)
	380V	400V	415V	380V	400V	415V	30 Batt/string	32 batt/string	40 batt/string	Bolt	Diameter of hole (mm)		
150	280	265	255	225	215	205	525	492	349	M8	6	M6	5
120	224	212	204	180	172	164	420	394	315				
90	168	159	153	135	129	123	315	295	236				
60	112	106	102	90	86	82	210	197	158				
30	56	53	51	45	43	41	105	98	79				

Tab. 1-3 Maximum steady state AC and DC Current

Note:

1. Input current of common input configurations of rectifier and bypass
2. Take special care when determining the size of the output and bypass neutral cable, as the current circulating on the neutral cable may be greater than nominal current in the case of non-linear loads, which is usually 1.732 times of rated currents..
3. The earth cable connecting the UPS to the main ground system must follow the most direct route possible. The earth conductor should be sized according to the fault rating, cable lengths, type of protection, etc. According to AS/IEC60950-1, the cross section area of the conductor is 80mm² (150kVA).
4. When sizing battery cables, a maximum volt drop of 4Vdc. is permissible at the current ratings given in *Tab. 1-3*. The load equipment is connected to a distribution network of individually protected busbars fed by the UPS output rather than connected directly to the UPS. In parallel multi-module systems, the output cable of each ups rack unit should be kept at equal length between the output of the ups rack output terminals and the parallel distribution busbar to avoid affecting the shared current. When laying the power cables, do not form coils, so as to avoid the formation of electromagnetic interference.
5. See Chapter 4 Installation Drawing for the positions of wiring terminals.

 Warning
FAILURE TO FOLLOW ADEQUATE EARTHING PROCEDURES CAN RESULT IN EMI, ELECTRIC SHOCK HAZARD OR RISK OF FIRE, SHOULD AN EARTH FAULT OCCUR.

UPS	150kVA UPS minimum distance to floor(mm)
Rectifier AC input bus	203
Bypass AC input bus	203
UPS AC output	200
Battery input bus	256
Auxiliary cables: Connected to monitoring board (U2)	1850

Tab. 1-4: Distances from floor to connection points

1.6.1 Cable Connections



Note

The operations described in this section must be performed by authorized electricians or qualified technical personnel.. If you have any difficulties, do not hesitate to contact our Customer Service & Support department at the address given at the beginning of this manual.

After the equipment has been finally positioned and secured, refer to Chapter 4 Installation Drawing to connect the power cables as described in the following procedures:

1. Verify that all the external input distribution switches of the UPS are completely opened and the UPS internal maintenance bypass switch is opened. Attach necessary warning signs to these switches to prevent unauthorized operation.
2. Open the doors of the UPS, remove the front protective cover and then the power connection buses are visible.
3. Connect the protective earth and any necessary grounding cables to the enclosure of the cabinet at the bottom part of the UPS rack (close to the cabinet side where the output connection terminal strips are located). The cabinet for the UPS must be connected to the user's ground connection.

Note: The grounding cable and neutral cable must be connected in accordance with local and national codes practice.

Identify and make power connections for incoming cables according to one of the two procedures below, depending on the type of installation:

Common Input Connections

4. For common bypass and rectifier inputs, connect the AC input supply cables to the UPS input terminals (mA-mB-mC-mN) Refer to Fig. 4-11 and tighten the connections to 5 Nm (M6 Bolt). **ENSURE CORRECT PHASE ROTATION.**

Split Bypass Connections

5. If a 'split-bypass' configuration is used, connect the AC input supply cables to the rectifier input terminals (mA-mB-mC-mN) Refer to Fig. 4-11 and the AC bypass supply cables to the bypass input terminals (bA-bB-bC-bN) and tighten the connections to 5 Nm (M6 Bolt). **ENSURE CORRECT PHASE ROTATION.**

Note: For split Bypass operation ensure that the busbars between Bypass and Rectifier inputs are removed. The neutral line of bypass input must be connected to that of the rectifier input.

Frequency Converter Mode

If the frequency converter configuration is used, connect the AC input cables to the rectifier input terminals (mA-mB-mC-mN) Refer to Fig. 4-11 and tighten the connections to 5Nm (M6 bolt), or to 13Nm (M8 bolt) or to 26Nm (M10 bolt). **ENSURE CORRECT PHASE ROTATION AND TIGHTEN CONNECTION TERMINALS.** No need to connect the bypass input cables to bypass input terminals (bA-bB-bC-bN).

Note: For the frequency converter operation mode, ensure that the busbars between Bypass and Rectifier inputs are removed.

Output System Connections

6. Connect the system output cables between the UPS output busbars (oA-oB-oC-N) Refer to Fig. 4-11 and the critical load and tighten the connections to 5 Nm (M6 Bolt). **ENSURE CORRECT PHASE ROTATION.**

	Warning
<p>If the load equipment will not be ready to accept power on the arrival of the commissioning engineer, then ensure that the system output cables are safely isolated at their ends.</p>	

7. Re-install all the protective covers.

1.7 Control Cabling And Communication

1.7.1 UPS Dry Contact And Parallel Signal Board X2 Features

According to the specific needs of the field, the UPS may need auxiliary connection to realize the management of the battery system (including external battery switch and battery temperature sensor), communicate with PC, provide alarm signal to external device, or realize remote EPO. These functions are realized through the UPS dry contact and parallel signal board X2 at the back of the front UPS door. The board provides the following interfaces:

- EPO
- Environment parameter input interface
- User communication interface (for parameter setting and host monitoring)
- Intellislots(TM) intelligent card interface
- Temperature detection interface

The UPS dry contact and parallel signal board X2 provides input dry contacts and output dry contacts.

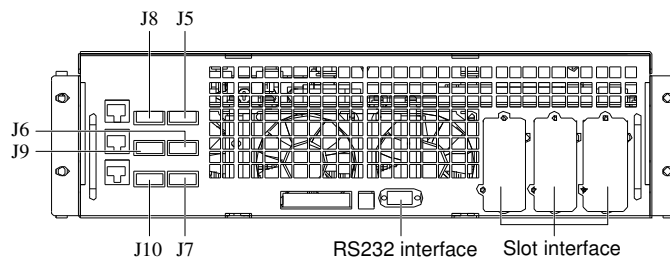

Fig. 1-4: Bypass Module (include Interfaces of dry contact and parallel signal board X2)

1.7.2 Input Dry Contact Interface

External input dry contacts are connected via the parallel signal board X2 board: Dry contacts are available for environment detection, battery ground fault detection, on Generator detection.

The UPS accepts external signal from zero-voltage (dry) contacts connected through external dry contact terminals produced and these terminals are in bypass module. Through software programming, these signals become active when these contacts connect to +12V to ground (in the most left side). The cables connected to DRY terminal must be separated from power cables. Moreover, these cables should be double insulated with a typical 0.5mm^2 to 1mm^2 cross-sectional area for a maximum connection length between 25 and 50 meters.

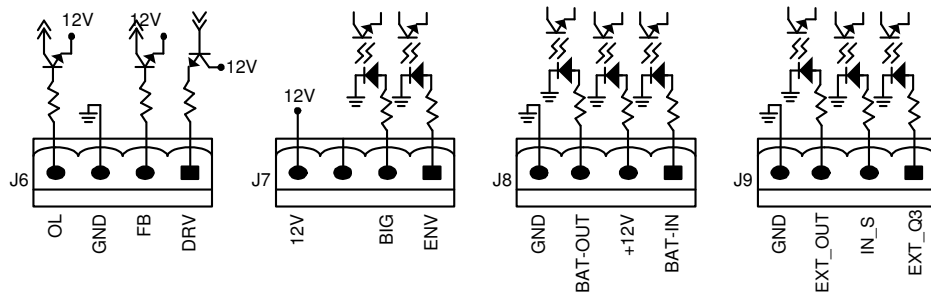

Fig. 1-5: Input dry contact interface

Position	Name	Meaning
J7.1	ENV	Detection of battery room environment (normally closed)
J7.2	BtG	Battery short to ground detection
J7.4	+12V	+12V power supply
J8.1	TMP_BAT_IN	Internal battery temperature detection
J8.2	+12V_A	+12V power supply
J8.3	TMP_BAT_OUT	External battery temperature detection
J8.4	GND_A	Power supply GND

Tab. 1-5: Description of dry contact input port

1.7.3 External Battery Circuit Breaker Interface

Position	Name	Descriptions
J6.1	DRV	BCB drive signal – (reserved)
J6.2	FB	BCB contact status (reserved)
J6.3	GND	Power supply GND
J6.4	OL	BCB online-Input (normally open): This pin is active when BCB interface signal is connected

Tab. 1-6: External battery circuit breaker interface

⚠	Note
All auxiliary cables must be double insulated twisted cables with cross sectional area of 0.5mm ² ~ 1.5mm ² for maximum connection length between 25m and 50m.	

1.7.4 External Maintenance Bypass Cabinet

Position	Name	Meaning
J9.1	EXT_Q3	Input circuit breaker status of External Maintenance Bypass Cabinet
J9.2	IN_S	Input circuit breaker status of internal Maintenance Bypass Cabinet
J9.3	EXT_OUT	Output circuit breaker status of External Maintenance Bypass Cabinet
J9.4	GND	Power supply GND

Tab. 1-7: External maintenance bypass cabinet Interface

Note 1: These contacts cannot be active unless they are set via software.

⚠	Note
All auxiliary cables must be double insulated twisted cables with cross sectional area of 0.5mm ² ~ 1.5mm ² for a maximum connection length between 25m and 50m.	

1.7.5 Output Dry Contact Interface

The J5 on the dry contact and parallel signal board X2 provides two output dry contacts, and J10 is the input interface for EPO. Refer to Fig. 1-4 and Tab. 1-8

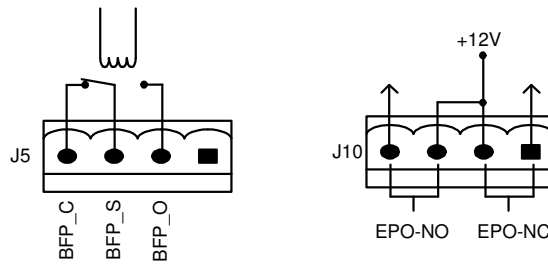

Fig. 1-6: Connections of output dry relay contacts and EPO

Position	Name	Meaning
J5.2	BFP_O	Bypass feedback protection - relay normally open.Closed when bypass SCR is short.
J5.3	BFP_S	Bypass feedback protection relay common
J5.4	BFP_C	Bypass feedback protection - relay normally closed.Opened when bypass SCR is short.

Tab. 1-8: Relay dry contact output port



Note

All auxiliary cables must be double insulated twisted cables with cross sectional area of 0.5mm² ~ 1.5mm² for a maximum connection length between 25m and 50m.

1.7.6 EPO Input Port

The UPS has an Emergency Power OFF (EPO) function. This function can be activated by pressing a button on the control panel of the UPS or through a remote contact provided by the user. The EPO pushbutton is protected by a hinged plastic cover.

As shown in Fig. 1-4, J10 is the input interface for remote EPO. The EPO is triggered when shorting pin 3 and pin 4 of J10, or opening pin 1 and pin 2.

If an external emergency stop facility is required, it is connected via the reserved terminals of pin 1 and pin 2 or pin 3 and pin 4 of J10. The external emergency stop facility needs to use shielded cables to connect to the normally open/closed' remote stop switch between these two pins (refer to Fig. 1-4, and Tab. 1-9). If this facility is not used, then pin 3 and pin 4 of J10 must be open, or pin 1 and pin 2 of J10 must be connected.

Position	Name	Meaning
J10.1	EPO_NC	EPO is activated when it is disconnected from J10.2
J10.2	EPO_NC	EPO is activated when it is disconnected from J10.1
J10.3	EPO_NO	EPO is activated when it is short circuited with J10.4
J10.4	EPO_NO	EPO is activated when it is short circuited with J10.3

Tab. 1-9: EPO input dry contact relay



Note

The emergency stop action within the UPS shuts down the rectifier, inverter and static bypass. However, it does not internally disconnect the mains input power supply. To disconnect ALL power to the UPS, open the upstream input circuit breaker(s) when the EPO is activated.

The normally closed EPO contacts of pin 1 and pin 2 of J10 are shorted before the UPS is delivered.

All auxiliary cables must be double insulated twisted cables with cross sectional area of 0.5mm² ~ 1.5mm² for a maximum connection length between 25m and 50m.

1.7.7 Battery temperature sensor

The external battery temperature sensor (option) is composed of a temperature probe and a temperature transmission board, as shown in Fig. 1-7. The battery temperature sensor is connected to the UPS monitoring board. When it is connected to the UPS, UPS will automatically detect the device and make compensate according to the temperature of battery.

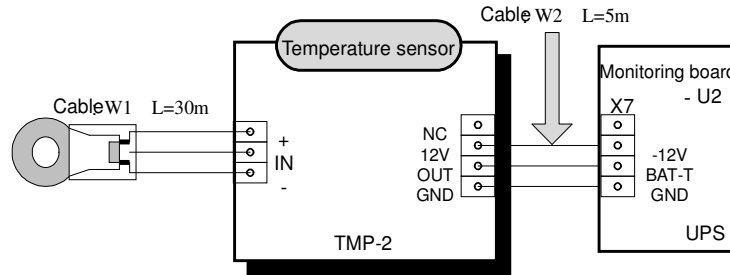

Cable W2 is delivered together with the temperature sensor

Fig. 1-7: A single battery temperature sensor and monitoring board

J8 port is used to connect internal battery temperature sensor and external battery temperature sensor.

Q1:+12V, GND, BAT-IN are for internal battery temperature sensor.

Q2:+12, GND, BAT-OUT are for external battery temperature sensor,

Q3: Battery temperature sensor must be purchased separately; the part number of the battery temperature sensor is at the beginning of this document.

Q4: J8 port is used to connect internal battery temperature sensor and external battery temperature sensor.

1.7.8 Other Interfaces

J2 and J3: Parallel connection port, is used for interacting parallel control signals between two UPS racks.

J4: LBS interface, used to synchronize outputs of two UPS rack module systems

Serial port RS232-2: A debug and maintenance port used for providing serial communication data and authorizing the commissioning and maintenance engineers.

Intellislot (TM) card interface: LIEBERT APM series UPS provides SNMP card communication interface that is used for installing site communication optional Intellislot (TM) card.

Chapter 2 Battery Installation

2.1 General Recommendations

Take special care when operating the batteries of the LIEBERT APM UPS system. When all the battery cells are connected, the battery voltage can exceed 400Vdc, which is potentially lethal.



Note

The precautions for battery installation, use and maintenance are to be provided by the batteries manufacturers. The precautions in this section include the key issues that must be considered during the installation design, which may be adjusted according to the specific local situations.



Battery Room Design

- *The battery shall be installed and stored in a clean, cool and dry environment.*
- *Do not install the battery in a sealed battery chamber or sealed room. The battery room ventilation shall at least meet the requirement of EN50272-2001. Otherwise, battery bulging, fire and even human injury may be caused.*
- *The battery shall be installed far away from the heating source (e.g. transformer). Do not use or store the battery in the place near the heating source or burn the battery or place it into fire. Otherwise, battery leakage, bulging, fire or explosion may be caused.*
- *Batteries shall be placed in such a manner that two bare live parts with the potential difference of more than 150V shall not be contacted at the same time. If it is unavoidable, insulated terminal cover and insulated cables shall be used for connection.*
- *If external batteries are to be used, the battery circuit breakers (or fuses) must be mounted as close as possible to the batteries, and the connecting cables should be as short as possible..*



Battery Handling

When connecting the battery, follow the precautions for high-voltage operation

- *Before accepting and using the battery, check the appearance the battery. If the package is damaged, or the battery terminal is dirty, corroded or rusted or the shell is broken, deformed or has leakage, replace it with new product. Otherwise, battery capacity reduction, electric leakage or fire may be caused.*
 - *Before operating the battery, remove the finger ring, watch, necklace, bracelet and any other metal jewelry*
 - *Wear rubber gloves.*
 - *Eye protection should be worn to prevent injury from accidental electrical arcs.*
 - *Only use tools (e.g. wrench) with insulated handles.*
- *The batteries is very heavy. Please handle and lift the battery with proper method to prevent any human injury or damage to the battery terminal.*
- *Do not decompose, modify or damage the battery. Otherwise, battery short circuit, leakage or even human injury may be caused.*
- *The battery contains sulfuric acid. In normal operation, all the sulfuric acid is attached to the separation board and plate in the battery. However, when the battery case is broken, the acid will leak from the battery. Therefore, be sure to wear a pair of protective glasses, rubber gloves and skirt when operating the battery. Otherwise, you may become blind if acid enters your eyes and your skin may be damaged by the acid.*
- *At the end of battery life, the battery may have internal short circuit, drain of electrolytic and erosion of positive/negative plates. If this condition continues, the battery may have temperature out of control, swell or leak. Be sure to replace the battery before these phenomena happen.*
- *If a battery leaks electrolyte, or is otherwise physically damaged, it must be replaced, stored in a container resistant to sulfuric acid and disposed of in accordance with local regulations.*
- *If electrolyte comes into contact with the skin, the affected area should be washed immediately with water.*

2.2 LIEBERT APM Battery typologies

According to the requested configuration LIEBERT APM UPS may need internal and/or external batteries

Liebert APM can utilize two different battery typologies:

- **Modular:** consisting of a number of battery boxes each containing 10 batteries that cannot be accessed w/o removing a protective cover, installed in the UPS and / or in a dedicated Modular Battery Cabinet, (MBC) that allows to extend the runtime as long as the systems or it's requirements grown adding additional battery modules on-the-fly by means of touch free blind mate connectors.
- **Traditional:** consisting of one or more strings of battery blocks installed on shelves in a locked cabinet or dedicated battery room



Note

- The battery modules, regardless if they are mounted internally to the UPS or in the MBC, make uses of strings of 30 batteries.
- The Traditional external battery cabinet can make use of each even number of battery per string between 30 and 40.
- The default factory setting, if the unit is ordered w/o internal battery is 40.
- The cabinet is only for valve regulated maintenance-free lead-acid battery.

CAUTION: -The lead acid battery may cause chemistry hazard

2.3 Safety

2.3.1 Modular Battery Cabinet.



Warning

- When handling the battery modules please refer to the label on it on how to operate
- Please use insulated glove to move battery modules.
- Do not to OPEN the battery boxes.
- Voltage between points 1 and 2 (Fig. 2-1) may exceed 150V DC, so they must not be touched and the cover shall be kept on when not installed

CAUTION: The lead acid battery may cause chemistry hazard

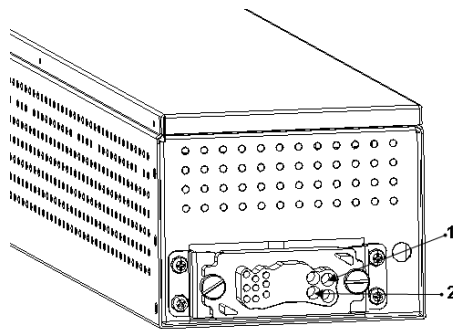

Fig. 2-1: Battery Box Back

Battery boxes should be stored in a cool place with the protective cover on . Hot and humid place will cause damage to Battery boxes.

2.3.2 Battery Installation

Only the qualified engineers are allowed to install and maintain mounted in a traditional battery cabinet or shelf. To ensure safety, install the external battery in a locked cabinet or dedicated battery room accessible just to service qualified personnel

Please note that number of cells set via software must be consistent with the actual number of cells.

A minimum space of 10mm must be reserved on all vertical sides of the battery block to permit free air movement around the cells.

A certain clearance should be reserved between the top of the cells and the underside of the shelf above as this is necessary for monitoring and servicing the cells.

When installing the batteries always work from the bottom shelf upwards to prevent raising the center of gravity. Install the batteries reliably and avoid vibration and mechanical bumping.

The bending radius of cable should be more than 10D, where "D" is the outer diameter of cable.

When connecting the cable, do not cross the battery cables and do not bind the battery cables together

The battery connection must be firm and reliable. After the connection, all the connections between the wiring terminals and the batteries must be corrected to meet the torque requirement provided in the specifications and user manuals of the battery manufacturers.

Each battery terminal should be insulated after its connection has been made.

Check if the battery is unexpectedly grounded. If the battery is unexpectedly grounded, remove the earth power supply. Contacting any part of the grounded earth may be subject to electric shock

Measure the battery voltage, and carry out battery voltage calibration after the UPS is started.



WARNING: Battery connections

When using a traditional battery solution, always comply with the following precautions:

- Disconnect the charging power before connecting or disconnecting the cable of the battery terminals.
- Do not connect the cables between the UPS battery terminals and the batteries before getting the approval from the commissioning engineer.
- When connecting the cables between the battery terminals and the circuit breaker, always connect the circuit breaker end of the cable first.
- Be sure to connect the positive/negative terminals of the batteries to those of the circuit breakers and those of the circuit breakers to those of the UPS respectively with reference to the markings of positive/negative terminals. Reverse connection of battery polarities will result in explosion, fire accident, the damage of batteries and UPS, and human injury.
- The battery connecting terminal shall not subject to any external force, such as the pulling force or twisting force of the cable. Otherwise, the internal connection of the battery may be damaged, and in severe case, the battery may catch fire.
- Do not connect power until the total voltage of the battery string is verified correct through measurement.
- Do not connect any conductor between the positive and negative terminals of the battery.
- Do not close the battery circuit breakers before getting the approval from the commissioning engineer.

2.4 Battery maintenance

For the battery maintenance and precautions, please refer to IEEE-Std-1188-2005 and the relevant manuals provided by the battery manufacturers.



Battery Maintenance Note

- Check to ensure that all the safety devices are in place and function normally. Check if the battery management parameter setting is normal particularly.
- Measure and record the air temperature in the battery room.
- Check if the battery terminals are damaged or have the symptom of heating, and if the shell or cover is damaged.
- Please fasten every bolt on the terminal according to the fastening torque specified in the table below .
- After 1-2 months of service, recheck to make sure that each screw has been fastened according to the specified torque. Otherwise there is risk of fire.
- CAUTION: Use the battery with the same capacity and type, if battery is replaced by an incorrect type, it can cause explosion.
- CAUTION: Dispose of used battery according to the local instructions

Chapter 3 Installation Of UPS Rack System And Parallel System

3.1 Overview

The single or parallel system should be installed according to the installation procedures of the UPS rack module system and the requirements in this Chapter.

For single UPS rack module installation the EPO button on the front panel of the UPS rack controls the emergency stop of UPS modules and bypass static switch and also supports remote emergency power off function that can be used to shut down the UPS rack module remotely.

 Note
1. The remote EPO switch must provide normally open or normally closed dry contact signals.
2. The open circuit voltage is 12Vdc, and the current is less than 20mA.
3. The external EPO provides a second set of contacts, which can turn off the UPS mains input circuit breaker or the bypass input circuit breaker with remote tripping mechanism.
4. Normally closed EPO-J10 terminals: Pin 1 and pin 2 have been connected in factory and located on the parallel signal board X2.

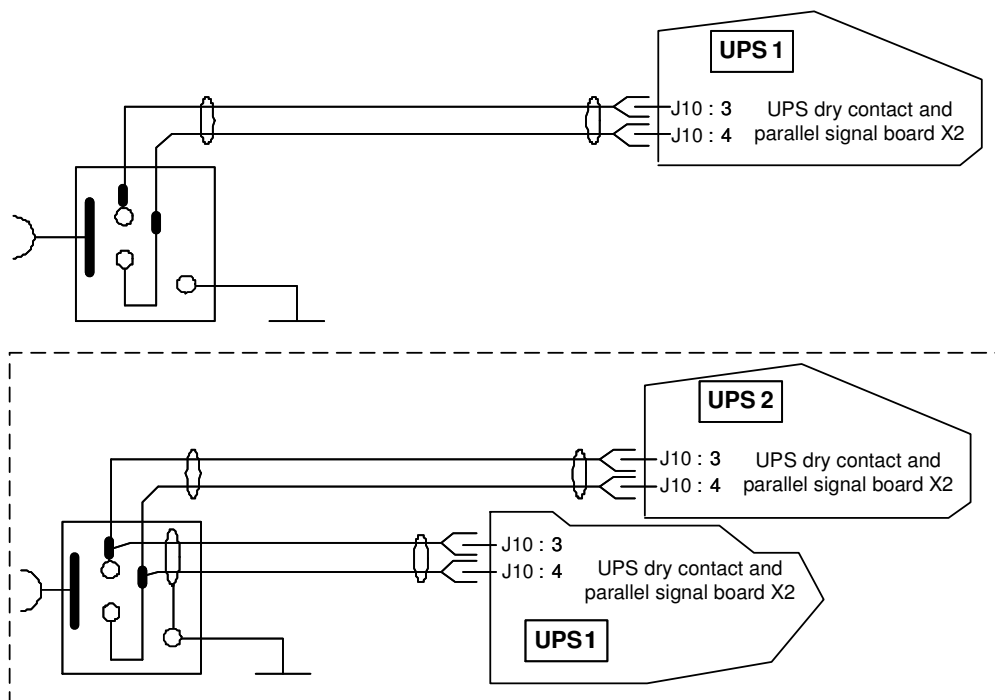

Fig. 3-1: Circuit ram of emergency power off

3.2 UPS Rack Modules In Parallel System

The basic installation procedures of parallel system are the same with those of the UPS rack module system. In this section, only the installation procedures related to the parallel system are introduced.

3.2.1 Installation Of Cabinet

To make the maintenance and system test easier, an external maintenance bypass is recommended in the installation.

3.2.2 External Protective Devices

Refer to Chapter 1 Installation

3.2.3 Power Cables

The power cable connection of the parallel rack module system is similar to that of the single UPS rack module system. If the bypass input and rectifier input share the same neutral terminal and if an RCD protective device is installed at the input, then the RCD device must be installed before the input cables are connected to the neutral terminal. Refer to Chapter 1 Installation

Note: The length and specification of the power cables of each UPS module should be the same, including the bypass input cables and UPS output cables, so that the load sharing effect can be achieved in bypass mode.

3.2.4 Control Cables

Parallel control cable

The parallel control cable has THREE types in terms of length: 5m, 10m, and 15m. All the parallel cables are designed to be shielded and double insulated, and are connected between the UPS rack modules to form a loop as shown below. The parallel signal board X2 is installed at the front of the static switch power module. This close loop connection ensures the reliability of the parallel system control. Refer to Fig. 3-2,

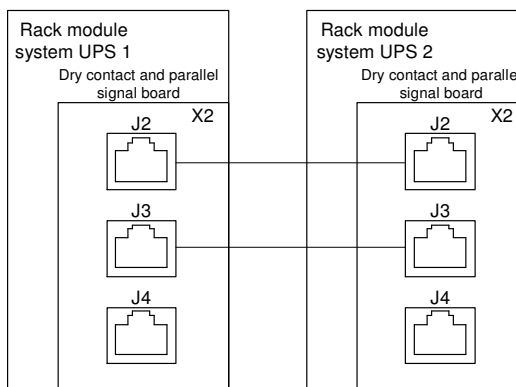

Fig. 3-2: Connection of parallel control cables of "1+N" system

Note: in Fig. 3-2, X2 is the dry contact and parallel signal board

3.3 Dual-Bus System

3.3.1 Installation Of Cabinet

The dual bus system (DBS) consists of two independent UPS rack module systems and each UPS system consists of one or more UPS power modules and a bypass power module. The dual bus system is configured for high availability and is suitable for powering the load with dual inputs. If the load is single-input load, the static transfer switch and LBS control is recommended to maintain both UPS outputs synchronized for uninterrupted transfers. Please install the system according to the installation descriptions for different system configurations.

All the UPS rack modules should be installed side by side, and the cables should be connected according to the following descriptions.

The LBS control synchronizes makes the outputs of two UPS rack modules (or parallel systems) synchronized. One system is set as the master unit and the other system is set as slave unit. The LBS enables the load to have two independent UPS sources.

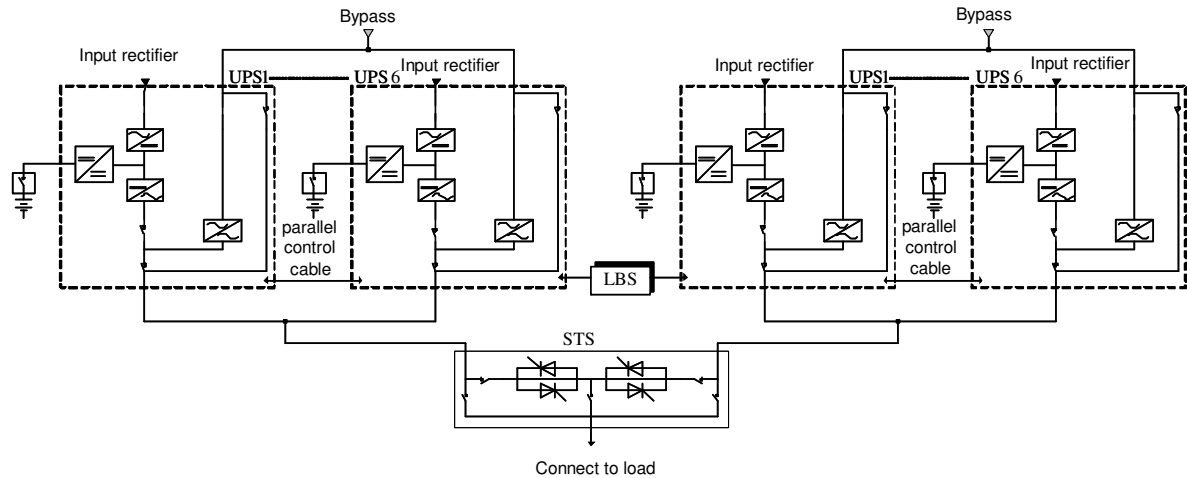

Fig. 3-3: Typical dual bus system (with static bypass switch LBS)

3.3.2 External Protective Devices

Refer to Chapter 1 Installation

3.3.3 Power Cables

The power cable connection of the parallel system is similar to that of the UPS module system. If the bypass input and rectifier input share the same neutral terminal, and if an RCD protective device is installed at the input, then the RCD device must be installed before the input cables are connected to the neutral terminal. Refer to Chapter 1 Installation. Notes: keep bypass currents balanced on bypass mode.

3.3.4 Control Cables

For LIEBERT APM to LIEBERT APM dual-bus system, use the optional LBS cables to connect any two digital LBS interfaces of the two paralleled UPS systems, as shown in Fig. 3-4.

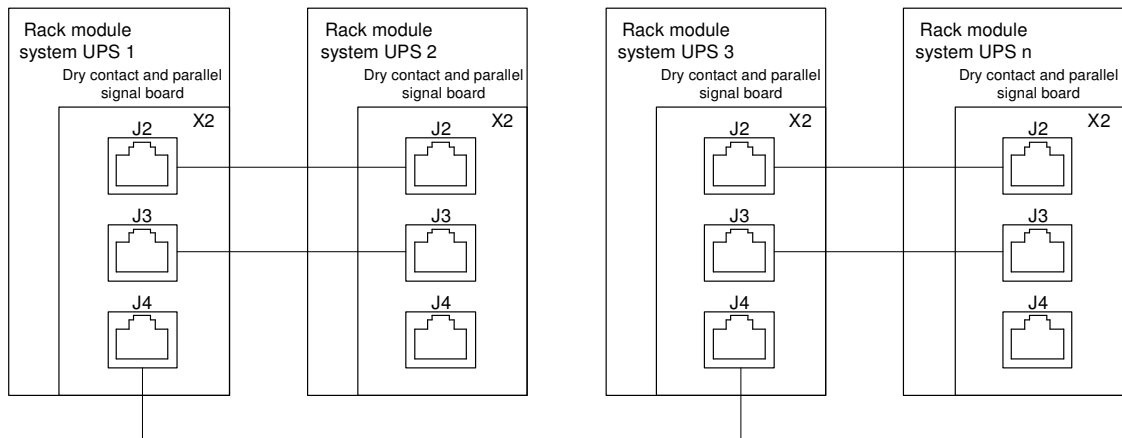

Fig. 3-4: Typical dual bus system (with LBS) consisting of two 1+1 parallel system

Chapter 4 Installation Drawing

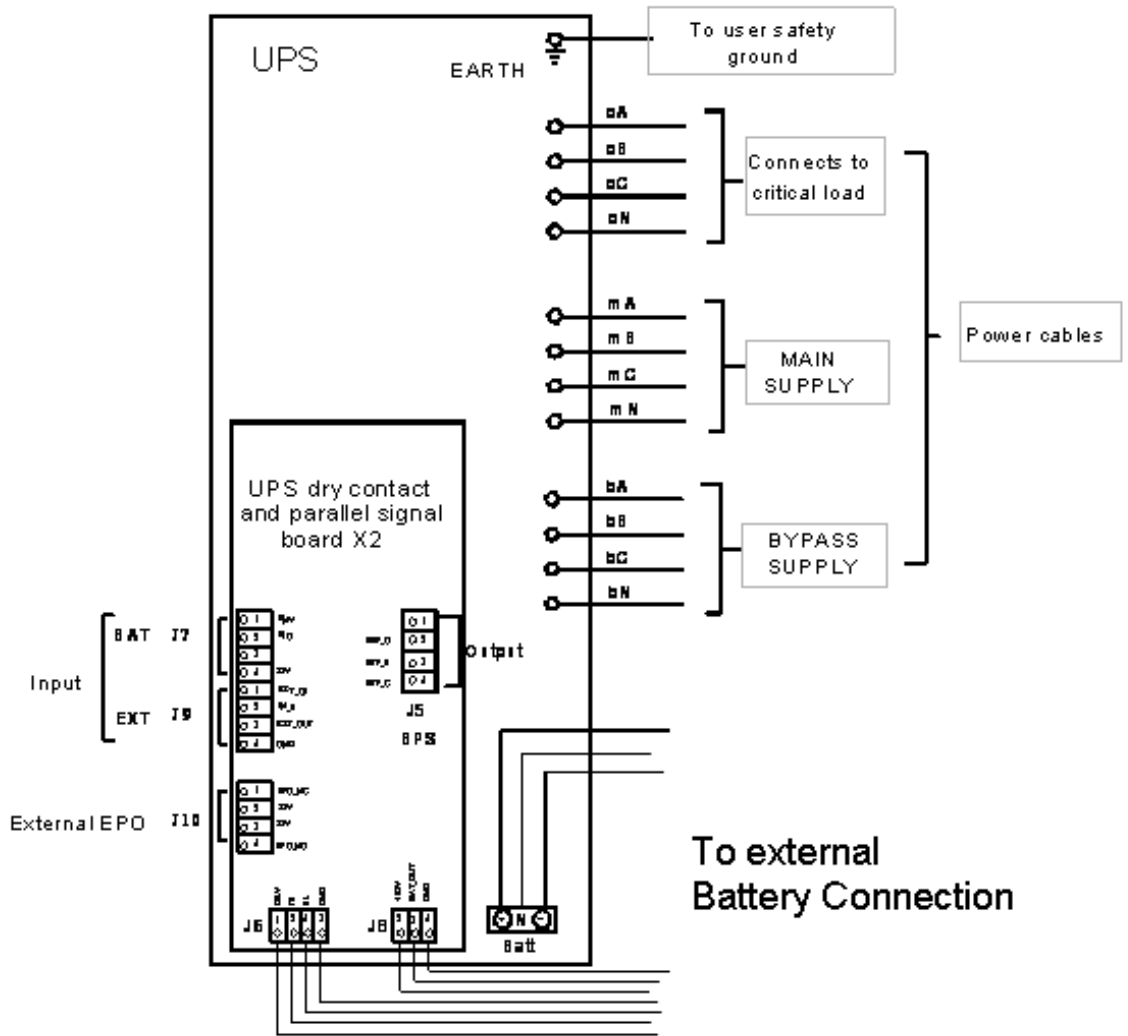

Fig. 4-1: Signal Wiring Diagram

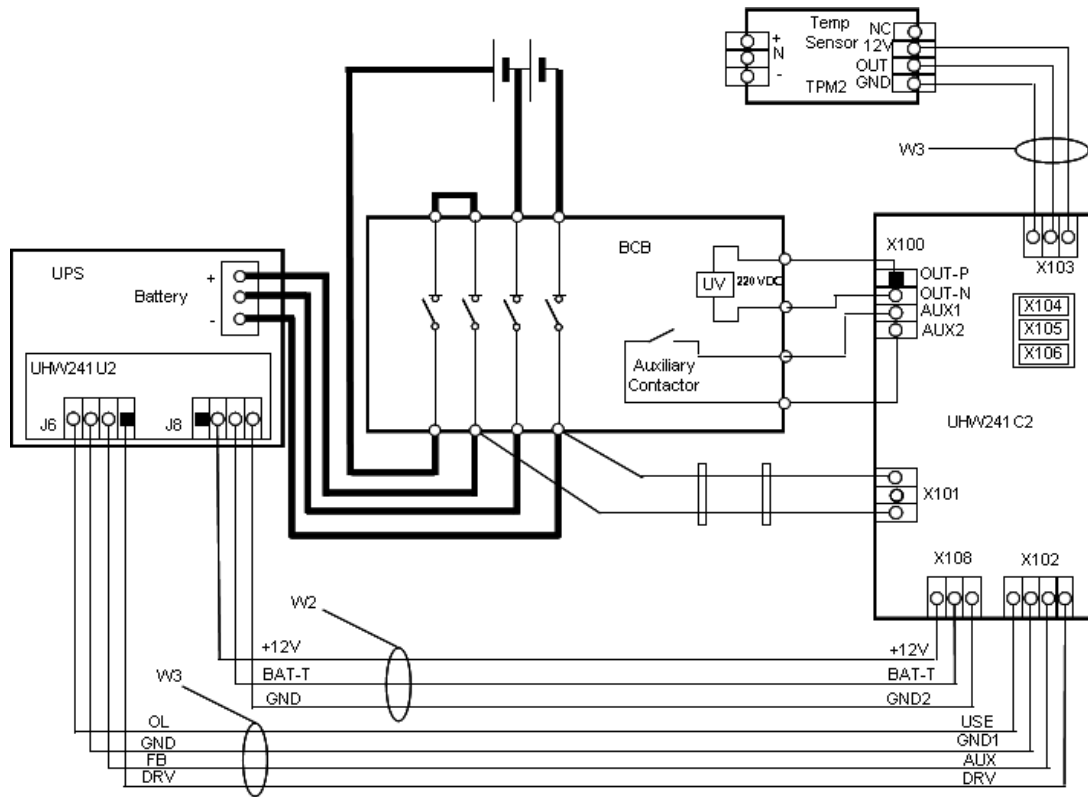

Fig. 4-2: External Battery Connections

- Externa BCB interface UHW242C2
 - J6.1 DRV: BCB: Drive signal
 - J6.2 FB: BCB: Contact status
 - J6.3 GND: Ground
 - J6.4 OLBCB: Online-Input (normally open): This pin is active when BCB interface signal is connected.

- BCB control board UHW242C2
 - Control and feedback X102 to J6, Bypass Module
 - External battery temperature, X108 to J8, Bypass Module
 - Battery +/- supply to X101
 - UV coil and auxiliary to X100
 - Battery temperature sensors X103, X104, X105, X106

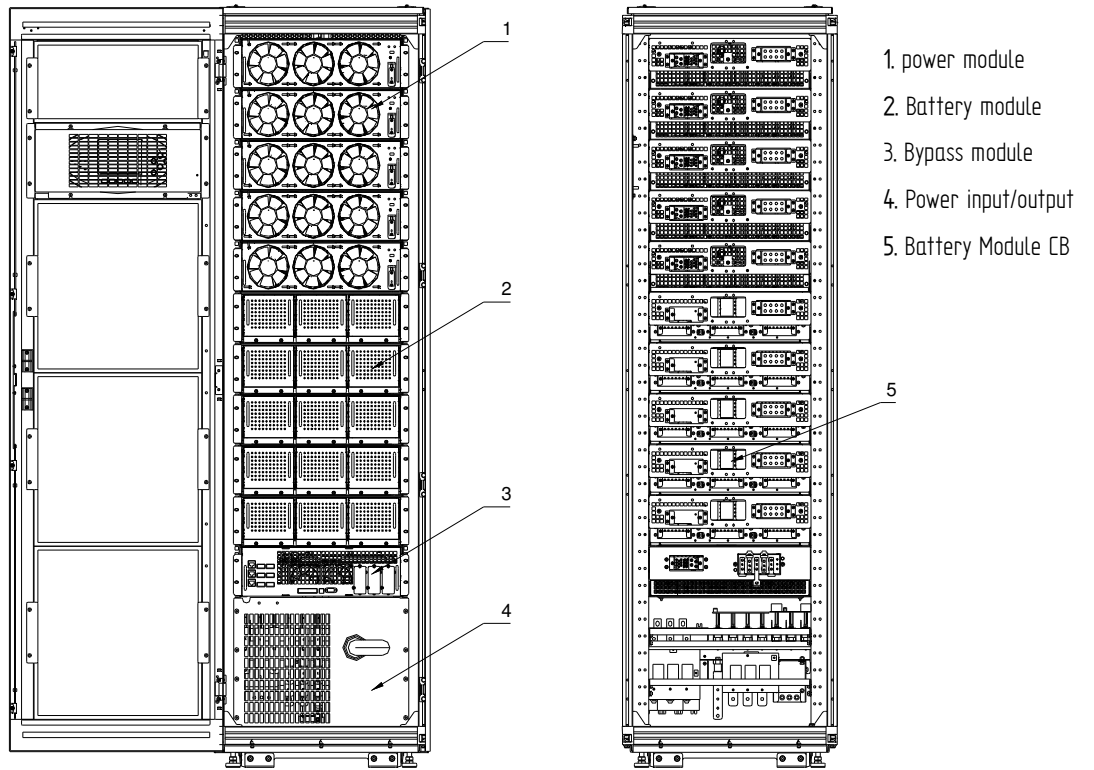

Fig. 4-3: 150kVA UPS module system, front view whit open door and back view without doors

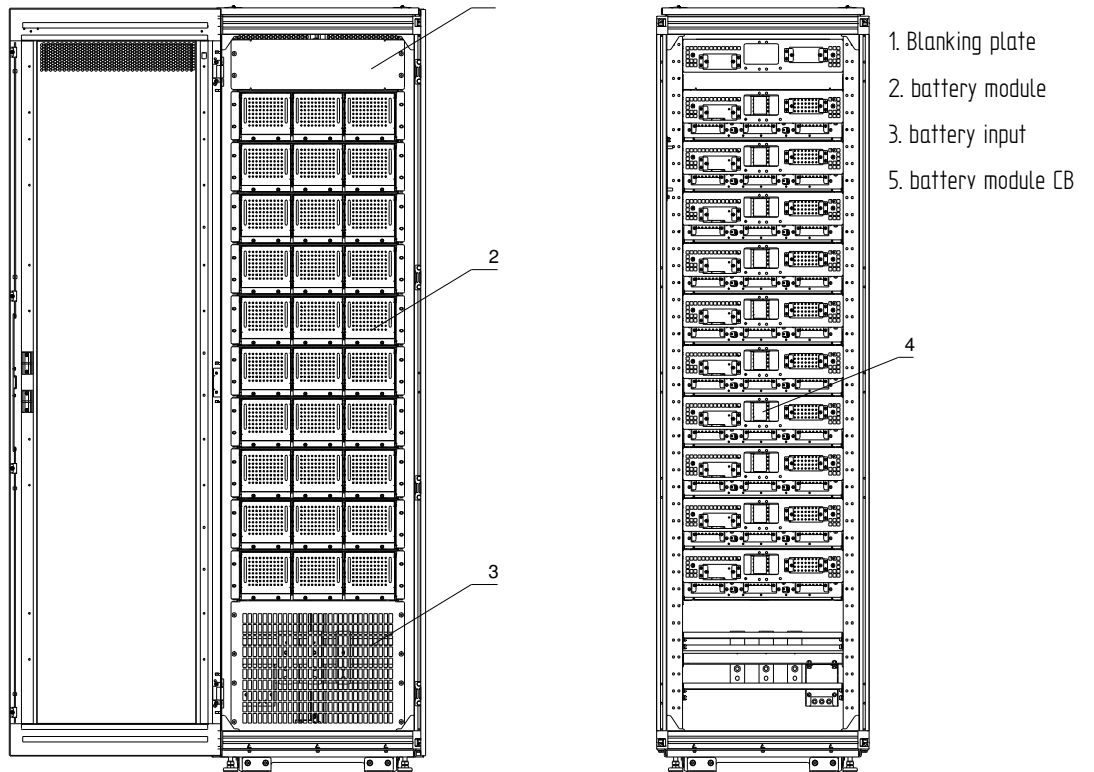

Fig. 4-4: Modular Battery Cabinet: front view with open door and back view without doors

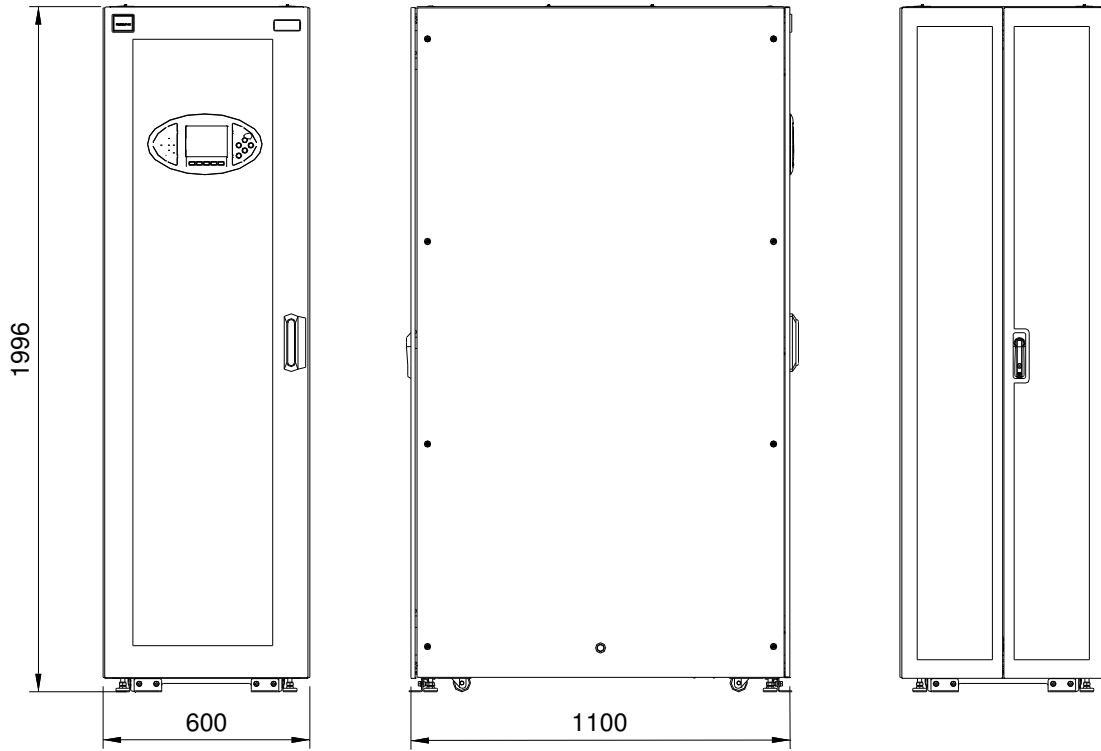

Fig. 4-5: UPS External dimensions

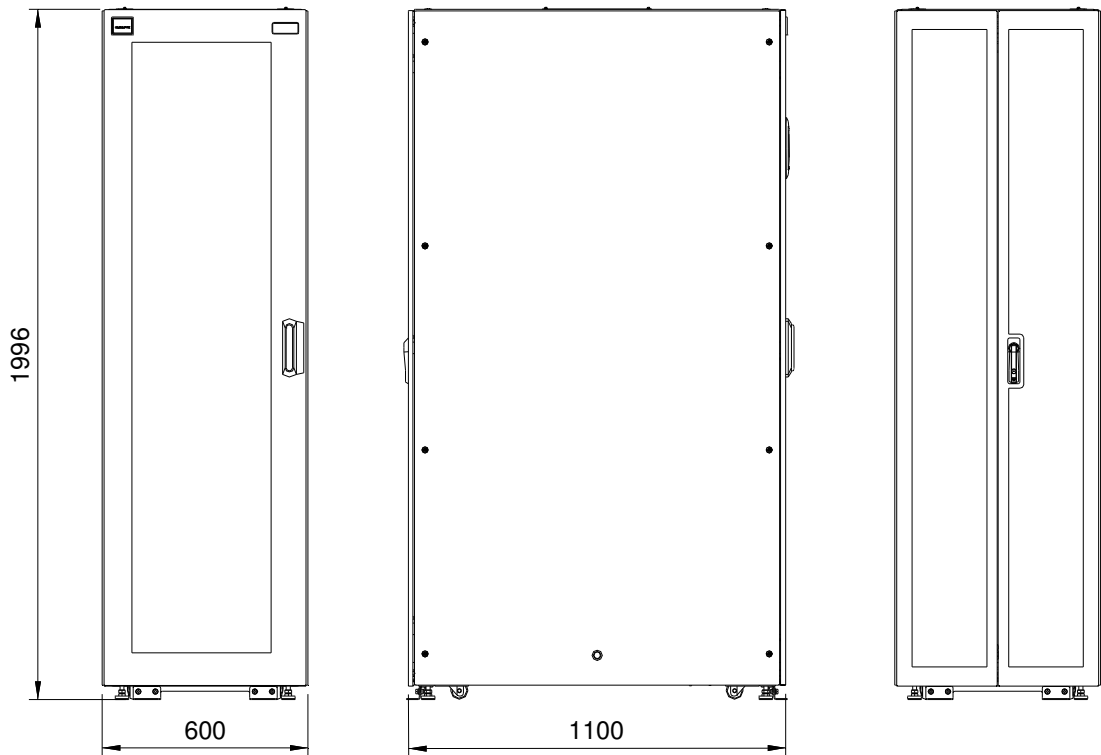

Fig. 4-6: Battery Cabinet External dimensions

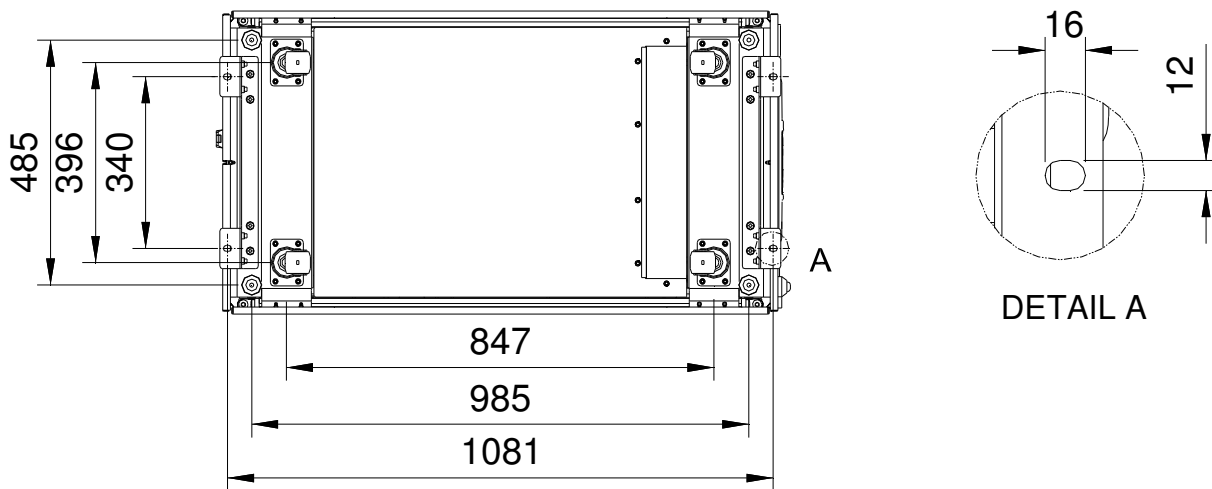

Fig. 4-7: UPS and BC bottom view show the position of casters and fixing holes

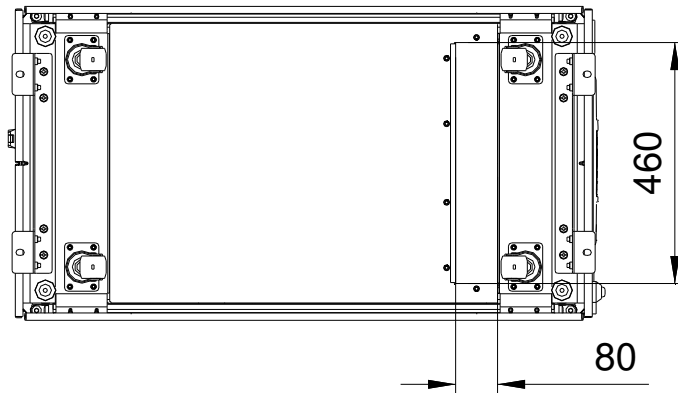

Fig. 4-8: UPS and BC bottom view show the cable entry area

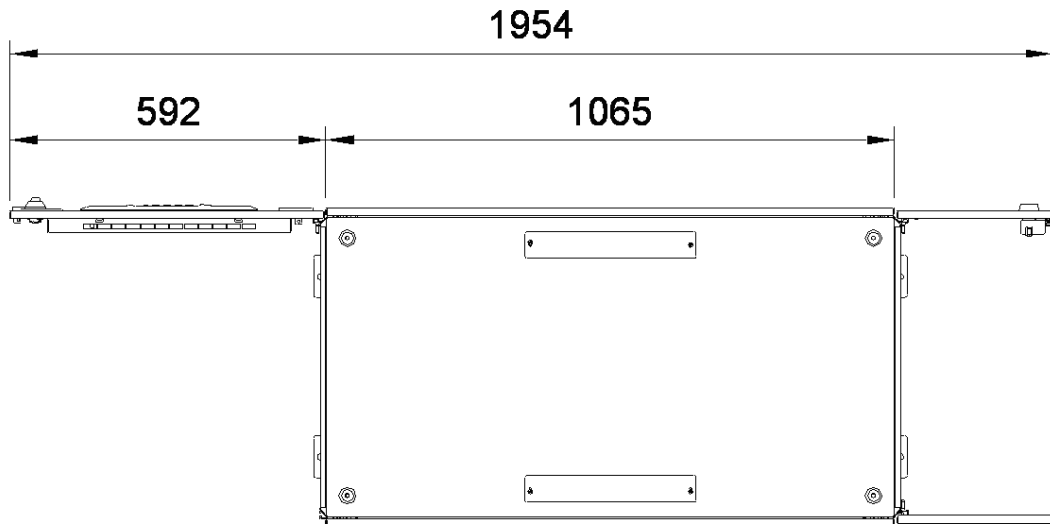

Fig. 4-9: UPS and BC top view with open doors

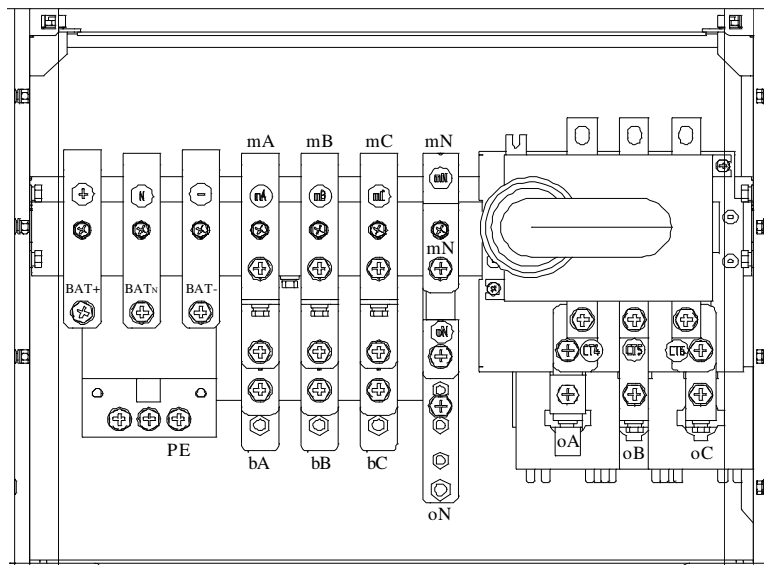

Fig. 4-10: AC and DC Connection

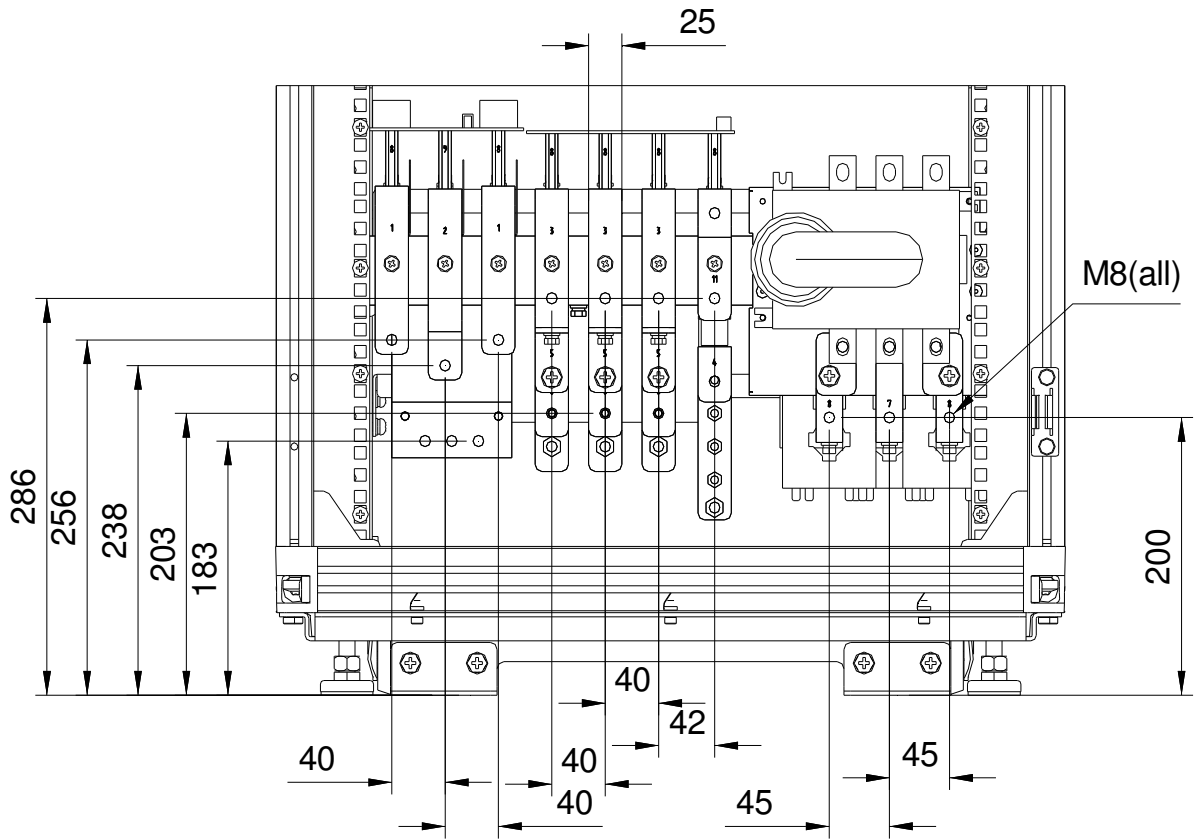

Fig. 4-11: AC And DC Connection details

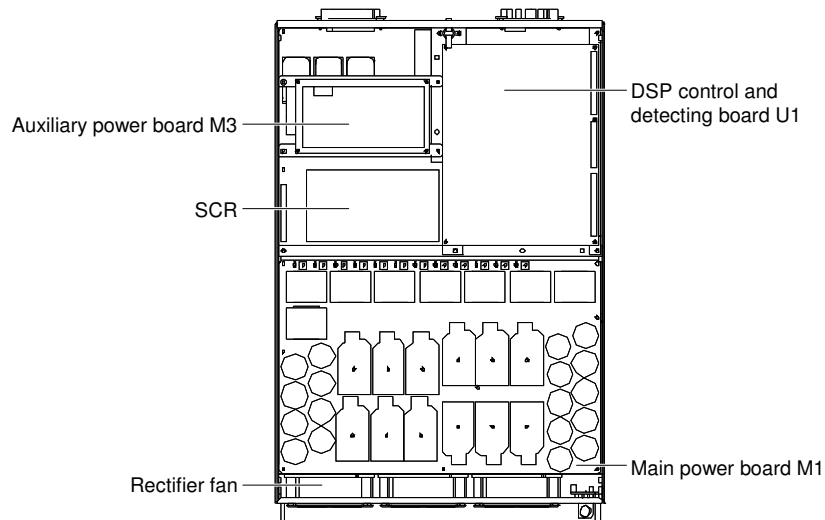

Fig. 4-12: Power Module

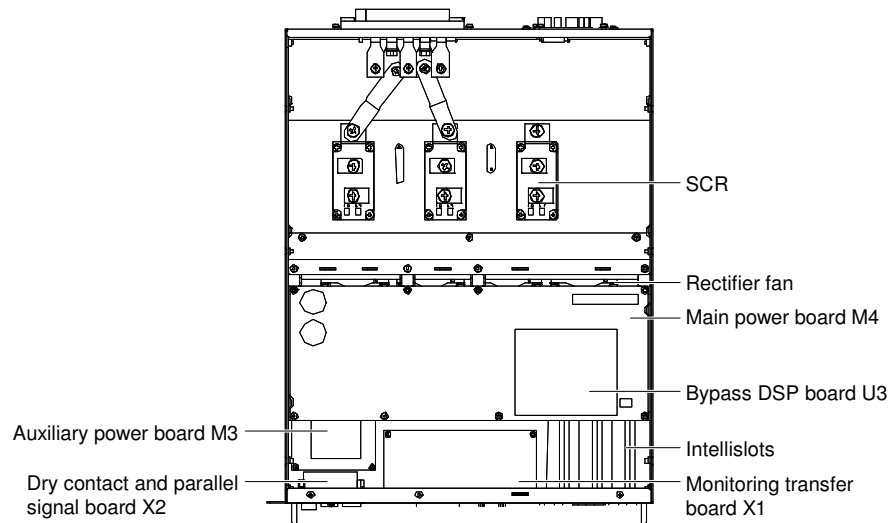

Fig. 4-13: Static Bypass Module

Notes for installing bypass power modules:

1. When installing the modules, install the modules from bottom to top. When removing the modules, remove the modules from top to bottom. The purpose is to maintain the stable center of gravity.
2. When inserting the module, ensure that the "Ready" switch is in unready status.
3. After inserting the module, tighten all the screws before closing the ready switch.
4. When removing the modules, turn off the ready switch first, remove the screws and then remove the modules.
5. Wait for 5 minutes before inserting the removed modules.

4.1 Internal Battery Module

4.1.1 Appearance Of Internal Battery Module

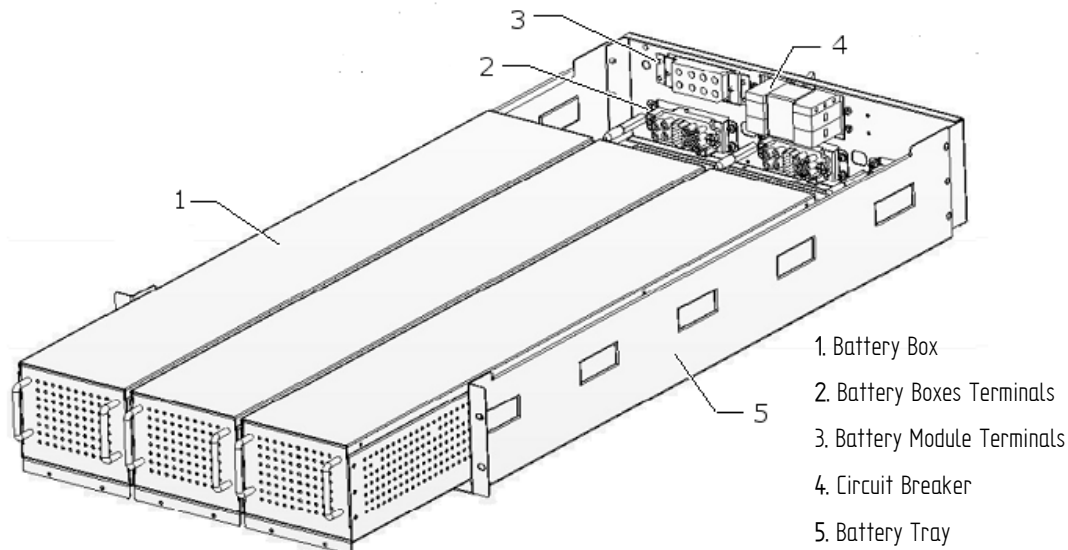

Fig. 4-14: Battery Module

According to the selected configuration, the LIEBERT APM can house from none to 9 battery modules connected in parallel.

Each Modular Battery Cabinet can house additional 10 modules of battery

Each module is made of 3 battery boxes and a battery tray. Each battery box contains ten 9AH/12V batteries and each battery tray has one 50A DC current limiting circuit breaker. The maximum discharging current of each layer of battery is 45A. Over charging current will trip the circuit breaker and the monitoring unit will display the alarm.



Note

When using modular battery it is important to install at least 2 battery module per each power module installed. Not doing that will result in the CB tripping before the battery reaches the EOD.



Note

Battery housed in the external Modular Battery Cabinet must be of the same kind of the internal ones.

Chapter 5 Operations

	<p>Warning: Hazardous mains voltage and/or battery voltage present(s) behind the protective cover</p>
<p>The components that can only be accessed by opening the protective cover with tools cannot be operated by user. Only qualified service personnel are authorised to remove such covers.</p>	

5.1 Introduction

The LIEBERT APM UPS provides the critical load (such as communication and data processing equipment) with high quality uninterruptible AC power. The power from the LIEBERT APM UPS is free from voltage and frequency variations and disturbances (interruption and spike) experienced at the Mains AC input supply.

This is achieved through high frequency double conversion power pulse width modulation (PWM) associated with full digital signal processing control (DSP), which features high reliability and convenience for use.

As shown in Fig. 5-1, the AC input mains source is supplied at UPS input and converted into a DC source. This DC source feeds the Inverter that converts the DC source into a clean and input independent AC source. The battery powers the load through the inverter in case of an AC input mains power failure. The utility source can also power the load through the static bypass.

When the UPS needs maintenance or repair, the load can be transferred to maintenance bypass without interruption and the power module and bypass module can be removed for maintenance.

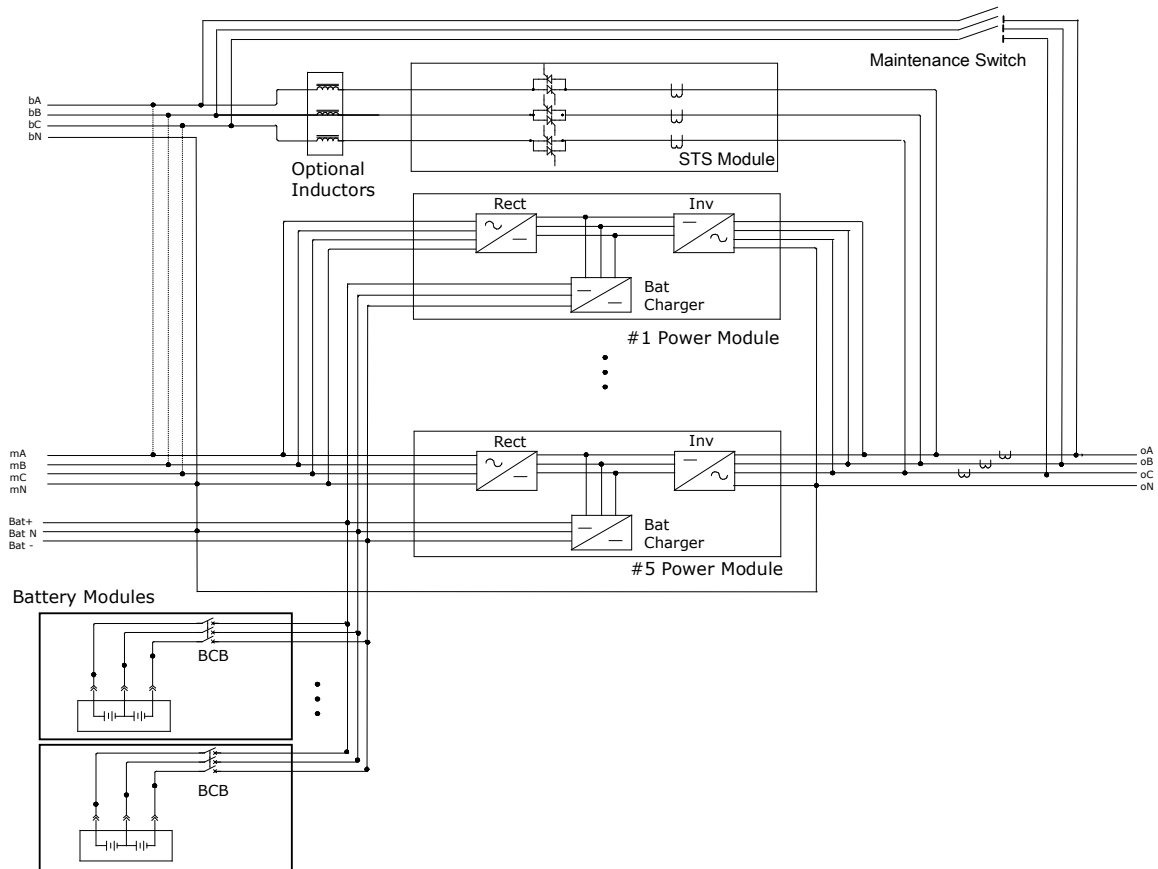

Fig. 5-1: Single unit block diagram

5.1.1 Split-Bypass Input

Fig. 4-1 illustrates the LIEBERT APM UPS in what is known as the split-bypass configuration (that is, the bypass uses a separate AC source). In this configuration, the static bypass and maintenance bypass share the same independent bypass power supply and connect to the power supply through a separate switch. Where a separate power source is not available, the bypass and rectifier input supply connections are linked.

5.1.2 Static Transfer Switch

The circuit blocks labeled Static Switch in Fig. 4-1 contain electronically controlled switching circuits that enable the critical load to be connected to either the inverter output or to a bypass power source via the static bypass line. During normal system operation the load is connected to the inverter; but in the event of a UPS overload or inverter failure, the load is automatically transferred to the static bypass line.

To provide a clean (no-break) load transfer between the inverter output and static bypass line, the inverter output and bypass supply must be fully synchronized during normal operating conditions. This is achieved through the inverter control electronics, which makes the inverter frequency track that of the static bypass supply, provided that the bypass remains within an acceptable frequency window.

A manually controlled maintenance bypass supply is incorporated into the UPS design. It enables the critical load to be powered from the utility (bypass) supply while the UPS is shut down for routine maintenance.



Note

When the UPS is operating in bypass mode or on maintenance bypass, the connected equipment is not protected from power failures or surges and sags.

5.2 1+N Parallel System

Several "single unit" UPS modules may constitute a "1+N" system, where up to four single units operate together for the purpose of providing additional power or reliability or both. The load is equally shared between any paralleled UPSes.

In addition, two UPS modules or 1+N groups may be configured as "distributed redundant" systems. Each UPS module or system has independent outputs that nevertheless are synchronized through a Load Bus Synchronizer (LBS) so that critical loads can be seamlessly transferred from one system to another. See 4.3 *Operating Mode* for more information.

5.2.1 Features Of Parallel System

1. The hardware and firmware of single module UPS units are completely compatible with the requirements of a parallel system. Parallel configuration can be achieved merely through settings in configuration software. The parameters settings for the modules in parallel system shall be consistent.
2. Parallel control cables are connected in a ring, providing both performance and redundancy. Dual-bus control cables are connected between any two UPS modules of each bus. The intelligent paralleling logic provides the user with maximum flexibility. For example, shutting down or starting up UPS modules in a parallel system can be done in any sequence. Transfers between Normal and Bypass modes of operation are synchronized and self-recovering e.g. following overloads and their clearance.
3. The total load of the parallel system can be queried from each module's LCD.

5.2.2 Parallel Requirements Of UPS Modules

A group of paralleled modules behave as if it were one large UPS with the advantage of presenting higher reliability. In order to assure that all modules are equally utilized and to comply with relevant wiring rules, the following requirements apply:

1. All UPS modules shall be of the same rating and must be connected to the same bypass source.
2. The bypass and the main input sources must be referenced to the same neutral potential.

3. Any RCD (Residual Current detecting device), if installed, must be of an appropriate setting and located upstream of the common neutral bonding point. Alternatively, the device must monitor the protective earth currents of the system. Refer to the *High Leakage Current Warning* in the first part of this manual.
4. The outputs of all UPS modules must be connected to a common output bus.
5. It is strongly recommended that each paralleled UPS install at least a redundant power module



Optional isolation transformers are available for applications where sources do not share the same neutral reference or where the neutral is not available.

5.3 Operating Mode

The LIEBERT APM UPS is an on-line, double-conversion, reverse-transfer UPS that permits operation in these modes:

- Normal mode
- Battery Mode
- Auto-restart mode
- Bypass mode
- Black start mode
- Maintenance mode (manual bypass)
- Parallel redundancy mode
- Sleep Mode

5.3.1 Normal Mode

The UPS inverter power modules continuously supplies the critical AC load. The rectifier/charger derives power from the AC mains input source and supplies DC power to the inverter while simultaneously FLOAT or BOOST charging its associated backup battery.

5.3.2 Battery Mode

Upon failure of the AC mains input power; the inverter power modules, which obtains power from the battery, supplies the critical AC load. There is no interruption in power to the critical load upon failure. After restoration of the AC mains input power, the "Normal Mode" operation will continue automatically without the necessity of user intervention.

5.3.3 Auto-Restart Mode

The battery may become exhausted following an extended AC mains failure. The inverter shuts down when the battery reaches the End of Discharge voltage (EOD). The UPS may be programmed to "Auto Recovery after EOD" after a delay time if the AC mains recovers. This mode and any delay time are programmed by the commissioning engineer.

5.3.4 Bypass Mode

If the inverter overload capacity is exceeded under normal mode, or if the inverter becomes unavailable for any reason, the static transfer switch will perform a transfer of the load from the inverter to the bypass source, with no interruption in power to the critical AC load. Should the inverter be asynchronous with the bypass, the static switch will perform a transfer of the load from the inverter to the bypass with power interruption to the load. This is to avoid large cross currents due to the paralleling of unsynchronized AC sources. This interruption is programmable but typically set to be less than 3/4 of an electrical cycle, e.g., less than 15ms (50Hz) or less than 12.5ms (60Hz).

5.3.5 Black Start Mode

If there is no utility input and want UPS to start from battery mode, UPS can start up from Black start mode

5.3.6 Maintenance Mode (Manual Bypass)

A manual bypass switch is available to ensure continuity of supply to the critical load when the UPS becomes unavailable e.g. during a maintenance procedure. This manual bypass switch is fitted in all UPS modules and rated for full load of one module.

5.3.7 Parallel Redundancy Mode (System Expansion)

For higher capacity or higher reliability or both, the outputs of several UPS modules can be programmed for direct parallel while a built-in parallel controller in each UPS ensures automatic load sharing. A parallel system can be composed of up to four UPS modules.

5.3.1 Sleep Mode

To improve system efficiency, when system capacity is high and the load is light you can decide to automatically shut down a number of power modules according to load level: if then the load increases, dormant modules are automatically started

To ensure that each module has equal chances of being selected as dormant and of dormancy duration, and that the life cycle of each module is consistent, the polling dormancy policy is adopted for the modules. The dormancy duration of each module can be set from 1 to 1000 days. When the dormancy duration of a module is reached, the module automatically starts, and the next module enters into the sleep mode.

If a system is configured to have X redundant power modules, the number of dormant modules is such that in any case, X module more than the ones required to sustain the load are not dormant .

It takes about one minute for the rectifiers and inverters of the dormant modules to start and share the load. During this period, the system may be overloaded and switch to bypass mode, so it is recommended to enable the sleep mode just when it is known that load changes slowly (e.g. by system upgrade) and not dramatically (e.g. by sudden changes of workload). Two dormancy parameters are available at the background: Intelligent UPS Dormancy Function and Module Dormancy Time.

Prerequisites for Enabling the Sleep Mode

To enter into sleep mode, the following prerequisites must be met:

The function of monitoring and setting dormancy is enabled.

The rectifier runs on the main channel without faults. The battery is almost fully charged.

The inverter does not report any fault or alarm.

The power supply for the bypass is available. The bypass voltage and SCR are normal.

This mode needs restricted module ID:

5 MODULE: ID SET 1, 2,3,4,5

4 MODULE: ID SET 1,2,3,4

3 MODULE: ID SET 1,2,3

2 MODULE: ID SET 1,2

5.4 Battery Management—Set During Commissioning

5.4.1 Normal Function

1. Constant current boost charging

Current can be set up.

2. Constant voltage boost charging

Voltage of boost charging can be set as required by the type of battery.

For Valve Regulated Lead Acid (VRLA) batteries, maximum boost charge voltage should not exceed 2.4V / cell.

3. Float Charge

Voltage of float charging can be set as required by the type of battery.

For VRLA, float charge voltage should be between 2.2V to 2.3V.

4. Float Charge Temperature Compensation (optional)

A coefficient of temperature compensation can be set as required by the type of battery.

5. End of discharge (EOD) protection

If the battery voltage is lower than the EOD, the battery converter will shut down and the battery is isolated to avoid further battery discharge. EOD is adjustable from 1.6V to 1.75V per cell (VRLA).

6. Battery Low Warning Time

It is adjustable between 3 and 60 minutes. The default is 5 minutes.

5.4.2 Advanced Functions (Software Settings Performed By The Commissioning Engineer)

Battery self-test and self-service

At periodic intervals, 20% of the rated capacity of the battery will be discharged automatically, and the actual load must exceed 20% of the rated UPS (kVA) capacity. If the load is less than 20%, auto-discharge cannot be executed. The periodic interval can be set from 30 to 360 days. The battery self-test can be disabled.

Conditions: Battery at float charge for at least 5 hours, load equal to 20~100% of rated UPS capacity

Trigger—Manually through the command of Battery Maintenance Test in LCD panel or automatically

Battery self-test interval: 30~360 days (default setting is 60 days)

5.5 Battery Protection (Settings By Commissioning Engineer)

Battery Low Pre-warning

The battery undervoltage pre-warning occurs before the end of discharge. After this pre-warning, the battery should have the capacity for 3 remaining minutes discharging with full load. The time is user configured from 3 to 60 minutes.

End of discharge (EOD) protection

If the battery voltage is lower than the EOD, the battery converter will be shut down. EOD is adjustable from 1.6V to 1.75V per cell (VRLA).

Battery Disconnect Devices Alarm

The alarm occurs when the battery disconnect device disconnects.

The external battery connects to the UPS through the external battery circuit breaker. The circuit breaker is manually closed and tripped by the UPS control circuit.

Chapter 6 Operating Instructions



Warning: Hazardous mains voltage and/or battery voltage present(s) behind the protective cover

The components that can only be accessed by opening the protective cover with tools cannot be operated by user. Only qualified service personnel are authorised to remove such covers.

6.1 Introduction

The LIEBERT APM UPS operates in the following 3 modes listed in Tab. 6-1. This section describes various kinds of operating procedures under each operating mode, including transfer between operating modes, UPS setting and procedures for turning on/off inverter.

Operating mode		Descriptions
Normal mode	NORMAL	UPS powers the load
Bypass mode	BYPASS	The load power supply is provided by the static bypass. This mode can be regarded as a temporary transition mode between the normal mode and maintenance bypass mode, or a temporary abnormal operating status
Maintenance Mode	MAINT	UPS Shuts down, the load is connects to the mains via Maintenance bypass. NOTE: in this mode the load is not protected against abnormal mains

Tab. 6-1 UPS Operating mode

Note:

1. Refer to *Chapter 7 Operator Control And Display Panel*, for all the user operating keys and LED displays.
2. The audible alarm may annunciate at various points in these procedures. It can be cancelled at any time by pressing the 'SILENCE ON/OFF' push-button.
3. The UPS function can be set via maintenance software. However, the setting and commissioning must be done by maintenance engineers trained by Emerson.

6.1.1 Power Switches

The UPS rack system only has a maintenance bypass isolating switch, and all the other transfers are processed automatically by internal control logics.

6.2 UPS Startup

Do not start the UPS until the installation is completed, the system has been commissioned by authorized personnel and the external power isolators are closed.

6.2.1 Start-Up Procedure

This procedure must be followed when turning on the UPS from a fully powered down condition.

The operating procedures are as follows:

1. Open the external power switch. Open the UPS door, connect the power supply cables and ensure the correct phase rotation.



Warning

During this procedure the UPS output terminals are live.

If any load equipment is connected to the UPS output terminals please check with the load user that it is safe to apply power: If the load is not ready to receive power then ensure that it is safely isolated from the UPS output terminals.

2. Close the external circuit breakers and connect the mains power.

The LCD starts up at this time. The Rectifier indicator flashes during the startup of rectifier. The rectifier enters normal operation state, and after about 30s, the rectifier indicator goes steady green. After initialization, the bypass static switch closes. The UPS Mimic LEDs will indicate as following:

LED	Status
Rectifier indicator	Green
Battery indicator	Off
Bypass indicator	Green
Inverter indicator	Off
Load indicator	Green
Status indicator	Amber

3. Press INVERTER ON button for two seconds.

The inverter indicator flashes during the startup of inverter. After the inverter is ready, the UPS transfers from bypass to inverter, the bypass indicator turns off, and the inverter and load indicators turn on.

The UPS is in normal mode. The UPS Mimic LEDs will indicate as following:

LED	Status
Rectifier indicator	Green
Battery indicator	Off
Bypass indicator	Off
Inverter indicatorchp888	Green
Output indicator	Green
Status indicator	Green

6.2.2 Procedures For Switching Between Operation Modes

Switch from normal mode to bypass mode

Press “inverter off” button to switch to bypass mode.

!	Note
In bypass mode, the load is directly fed by the mains power instead of the pure AC power from the inverter.	

Switch from bypass mode to normal mode

Press “inverter on” button in bypass mode. After the inverter enters normal operation, the UPS transfers to normal mode.

6.3 Battery Start

You can also use cold start mode with battery to start LIEBERT APM UPS from battery (charged) mode.

1. Verify that the battery is properly connected.
2. Press the battery start button (see Fig. 6-1) on the front panel of any power module.

At this point, the LCD displays the start screen, and the battery indicator flashes green. It stops flashing and becomes solid green about 30 seconds after the rectifiers enter normal operation.

3. Press and hold the INVERTER ON key for two seconds, and the UPS operates in battery mode.

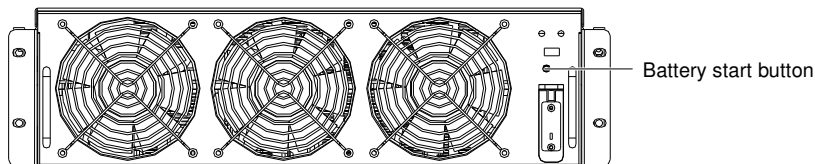

Fig. 6-1: Location of battery start button

6.4 Procedure For Switching The UPS Into A Maintenance Bypass From Normal Mode

This procedure can transfer the load from the UPS inverter output to the maintenance bypass supply, but the precondition is that the UPS is in normal mode before the transfer.



Caution

Before making this operation, read messages on display to be sure that bypass supply is regular and the inverter is synchronous with it, so as not to risk a short interruption in powering the load.

1. Press the INVERTER OFF switch on the right side of the operator control panel for longer than two seconds (if system is a interrupt transfer, there is a prompt to alarm and you must confirm the interrupt transfer). The UPS Mimic indicator Inverter ON will extinguish and also the Status Indicator (6) will turn amber and will be accompanied by an audible alarm. The load transfers to static bypass, and the inverter shuts down.



Note

Pressing the Alarm Silence ON/OFF button cancels the audible alarm but leaves the warning message displayed until the alarm condition is rectified.

2. Open the UPS door, close the maintenance bypass switch on the right bottom of the unit from OFF to ON position. The load power supply is provided by the manual maintenance bypass.



Warning

If you need to maintain the module, wait for 10 minutes to let the DC bus capacitor fully discharge before removing corresponding module.

When the maintenance bypass switch is on position of ON, some part of the UPS circuit still has hazardous voltage. Therefore, only qualified person can maintain the UPS.



Caution

When the UPS is in maintenance bypass mode, the load is not protected against abnormal mains supply.

6.5 Procedure For Completely Powering Down A UPS

If you need to power down the UPS completely, follow the procedures in section 6.3 to transfer the UPS from normal mode to maintenance bypass mode.

If you need to isolate the UPS from the AC power supply, you should open the external input power supply isolation first (if the rectifier and bypass use different power supply, you need to open these two input isolation respectively).



Warning

Shut down the maintenance power supply to avoid human injury.

6.6 EPO Procedure

The EPO button is designed to switch off the UPS in emergency conditions (e.g., fire, flood, etc.). To achieve this, just press the EPO button, and the system will turn off the rectifier, inverter and stop powering the load immediately (including the inverter and bypass), and the battery stops charging or discharging.

If the input utility is present, the UPS control circuit will remain active; however, the output will be turned off. To completely isolate the UPS, you need to open the external mains input supply to the UPS rack.

6.7 Auto Start

Commonly, the UPS rack is start up on static bypass. When the mains power fails, the UPS draws power from the battery system to supply the load until the battery voltage reaches the end of discharge (EOD) voltage, and the UPS will shut down.

The UPS will automatically restart and enable output power:

- After the mains power is restored
- If the Auto Recovery after EOD Enabling feature is enabled
- After auto start delay (default setting is 10 minutes), The UPS charges the battery during the auto restart delay to avoid the power failure risk to the load due to the second time of mains power failure

If the auto start function is not set in the UPS, the user can press Fault Clear to manually start the UPS.

6.8 UPS Reset Procedure

After using EPO to shut down the UPS, or after the UPS is shut down due to inverter over temperature, or overload, or battery over voltage or too many switching times (BYP: XFER COUNT BLOCK), and after clearing all the faults according to the prompt information displayed in screen, carry out this procedure to restore the UPS to normal operation.

After confirming that the fault is cleared, perform the following procedures:

1. Press FAULT CLEAR to reset the EPO status.
2. Press INVERTER ON button on the right side of the operator and control panel for longer than 2s.



Note

The rectifier will be turned on automatically when the overtemperature fault disappears at 5 minutes after the disappearance of overtemperature signals.

After pressing the EPO button, if the UPS mains input has been disconnected, the UPS is completely powered down. When the mains input is restored, the EPO condition will be cleared and the UPS system will enable static bypass mode to restore the output.



Warning

If the maintenance bypass isolatingswitch is put to ON and the UPS has mains input, then the UPS output is emergised.

The UPS module needs 10 minutes to discharge to safe voltage, do not operate on the UPS during this time.

6.9 Operation Instruction For Power Module Maintenance

Only a trained operator can perform the following procedures

Maintenance guidance for power modules

If the system is normal mode and the bypass is normal:

1. Press inverter off button on the front panel to manually power off the inverter and the UPS transfers to bypass.
2. Disconnect the Ready switch of the main power module that needs maintenance or repair.
3. Loosen the screws of the main power module and remove the module after 2 minutes.



Note

Note: To ensure the safety, be sure to use a multimeter to measure the DC bus capacitor voltage and ensure the voltage is below 60V before operation.

4. After finishing the maintenance of the main power module, confirm that the ID of the main power module is different from that of other power modules in operation, and it is within 1 to 5. If they are the same, adjust to different address bit.

5. Insert the main power module (the inserting interval for each module is longer than 10s), confirm that the Ready switch of the main power module is in DISCONNECT status, and then tighten the screws at the two sides of the power module.
6. Wait for 2 minutes, and then connect the Ready switch of the main power module. The power module will automatically join the system operation.

Maintenance guidance for bypass power module



Note

The bypass power module cannot be maintained in battery mode.

If the system is normal mode and the bypass is normal:

1. Manually shut down the inverter, and the UPS transfers to bypass. Close the maintenance bypass switch and the UPS transfer to maintenance bypass mode.
2. Press EPO button to ensure the battery current is 0. Open the battery circuit breaker or disconnect battery terminals.
3. Disconnect the ready switch of each power module and remove all the power modules.
4. Remove the bypass power modules that need maintenance or repair, wait for 5 minutes and then maintain the bypass power modules.



Note

Note: To ensure the safety, be sure to use a multimeter to measure the DC bus capacitor voltage and ensure the voltage is below 60V before operation.

5. After finishing the maintenance of the bypass power modules, insert the modules. Wait for 2 minutes, if the bypass indicator turns steady green, it indicates that the bypass supplies power normally.
6. Confirm that the address bit of the main power module is different from that of other power modules in operation, and it is within 1 to 5. If they are the same, adjust to different address bit.
7. Insert the main power module (the inserting interval for each module is longer than 10s), confirm that the Ready switch of the main power module is in DISCONNECT status, and then tighten the screws at the two sides of the power module.
8. Connect the ready switch of main power module (ensure at least 10s of interval for each module), let each module enter ready status.
9. Turn off the maintenance bypass switch, and the system transfers to bypass.
10. Manually power on the inverter, and the UPS transfers to inverter.

6.10 Language Selection

The LCD menus and data display are available in 12 languages: Chinese, Dutch, English, French, German, Italian, Japanese, Polish, Portuguese, Russian, Spanish and Swedish.

Perform the following procedure to select a language needed:

1. In main menu, press F1 (transfer window) to move the cursor to the first row of the menu in the LCD screen.
2. Press F2 (move left) or F3 (move right) to select the Language menu.
3. Press F1 (transfer window) to move the cursor to the UPS data window in LCD screen.
4. Press F2 (move up) and F3 (move down) to select the language needed.
5. Press F4 (confirm) to validate the selection.
6. Press F1 (ESC) repetitively to return to main menu. At this time, all the words in the LCD will be displayed in the selected language.

6.11 Changing The Current Date And Time

To change the system date and time:

1. In main menu, press F1 (transfer window) to move the cursor to the first row of the menu in the LCD screen.
2. Press F2 (move left) or F3 (move right) to select the Function Setting menu.
3. Press F1 (transfer window) to move the cursor to the UPS data window in LCD screen.
4. Press F2 (move up) and F3 (move down) to select the Date and Time setting, and then press F4 (confirm).
5. Move the cursor to the display row of date and time, and press F4 (confirm).
6. Press F2 (move up) and F3 (move down) to validate the current date and time.
7. Press F4 (confirm) to validate the setting and press F1 (ESC) to return to the main menu.

6.12 Control Password

The system is password protected to limit the operator's operating and control authorities. You can only operate and test the UPS and battery after entering correct password.

Chapter 7 Operator Control And Display Panel

7.1 Introduction

The operator control and display panel is located on the front panel of the UPS. Through this LCD panel, the operator can operate and control the UPS, and check all measured parameters, UPS and battery status and event and alarm logs. The operator control panel is divided into three functional areas from left to right: mimic current path, LCD display & menu keys, and control and operation keys.

Detailed view of control panel

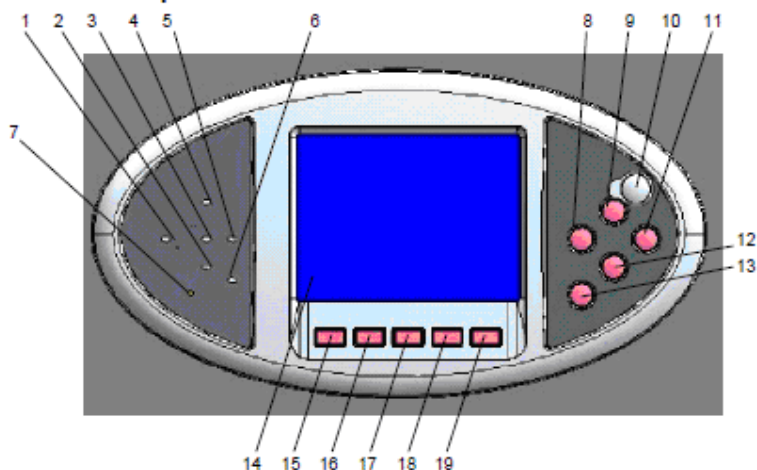

Fig. 7-1: UPS operator control and display panel

Part No.	Function	Part No.	Function
1	Rectifier indicator (AC to DC)	8	Inverter start
2	Battery indicator (backup DC power)	9	EPO switch
3	Inverter indicator (DC to AC)	10	Protective cover of EPO
4	Bypass indicator (AC to AC)	11	Fault reset
5	Load indicator (AC output)	12	Alarm mute
6	UPS status and alarm indicator	13	Inverter shutdown
7	Audible alarm (buzzer)	(15~19)	F1~F5 LCD menu key

Tab. 7-1: Descriptions of UPS operator control and display panel

7.1.1 Mimic Current Path

The LEDs shown on the mini current path represent the various UPS power paths and show the current UPS operating status.

Steady Green	Load on Rectifier
Flashing Green	Utility Normal, but rectifier not operating
Steady Red	Rectifier fault
Off	Rectifier has no fault, and utility abnormal

Tab. 7-2: Status description of rectifier indicator (1)

Steady Green	Battery powers the load
Flashing Green	Battery pre-warn

Steady Red	Battery or battery converter abnormal (Battery Failure, No Battery, Battery Reverse, battery converter fault, battery converter over temperature, battery converter over current)
Off	Battery and converter have no fault, and battery is charging

Tab. 7-3: Status description of bypass indicator (2)

Steady Green	Bypass powers the load
Steady Red	Bypass out of normal range, or static bypass switch fails
Off	Bypass Normal

Tab. 7-4: Status description of bypass indicator (3)

Steady Green	Inverter powers the load
Flashing Green	Inverter ON, during soft start, synchronization or standby (ECO mode)
Steady Red	Inverter fail
Off	Inverter normal, but off

Tab. 7-5: Status description of inverter indicator (4)

Green	UPS output ON, and no overload
Red	UPS output ON, but overload
Off	UPS has no output

Tab. 7-6: Status description of load indicator (5)

Steady Green	UPS is working normally
Steady Yellow	UPS has general alarm (for example: AC fault)
Steady Red	UPS has serious fault (for example: fuse or hardware fault)

Tab. 7-7: Status description of status (alarm) indicator (6)

7.1.2 Audible Alarm (Buzzer)

Short single click	The sound can be heard when any button is pressed
1 sec click with a 1 sec interval	when system has general alarm (for example: AC fault), this audible alarm can be heard
Continuous alarm	When system has serious faults (for example: fuse or hardware fault), this audible alarm can be heard

Tab. 7-8: Audible alarms descriptions

7.1.3 Functional Keys

EPO switch	To cut off the load powerTo shut down the rectifier, inverter, static bypass and battery
Inverter ON	Used to start the inverter
Inverter shutdown button	Used to shut down the inverter
Fault reset button	Press this key to restart the UPS after the fault is cleared
Alarm mute button	Used to silence the alarm, and re-pressing the button will sound the buzzer again







Tab. 7-9: Functional keys Description

7.1.4 LCD And Menu Buttons

The LCD display is a 320 × 240 dots graphic display that is friendly to user. The LCD can display alarm information in real time. 1024 historical records can be stored and retrieved for reference and diagnosis.

Through the graphic LCD display and a user-friendly menu-driven operator system, the user can easily browse the parameters for input, output, load and batteries and the current UPS status and warnings are always put forward automatically for quick reference. The versions of converter firmware, inverter firmware, bypass firmware and internal monitor firmware can be displayed on the LCD.

Five menu buttons are used for selecting the menu to be displayed.

Button	F1	F2	F3	F4	F5
Function 1	 Home	ESC Exit	 Move left	 Move right	 Confirm
Function 2			 Move up	 Move down	

Tab. 7-10: Icons of functional keys and the meanings

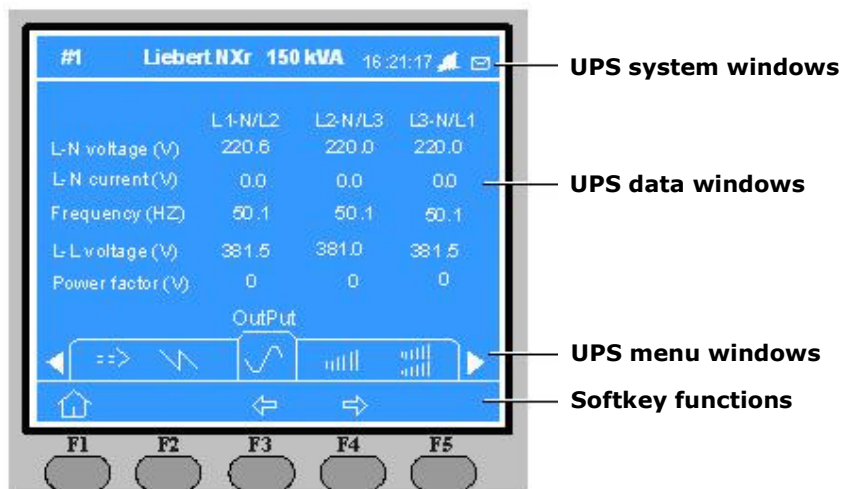

Fig. 7-2: Sections of the LCD and menu buttons

The icons above the F1 to F5 buttons clearly explain the meaning of each button. As shown in Fig. 7-2 pressing F1 can move the cursor (at AC Output) from menu window (2) to the current event log window (4), and firstly move the cursor to “Close rectifier input circuit breaker”. Pressing F2 can move the cursor from “AC Output” menu to “Bypass Input” menu.

The LCD menu tree is shown below. Please refer to Tab. 7-13: UPS event log

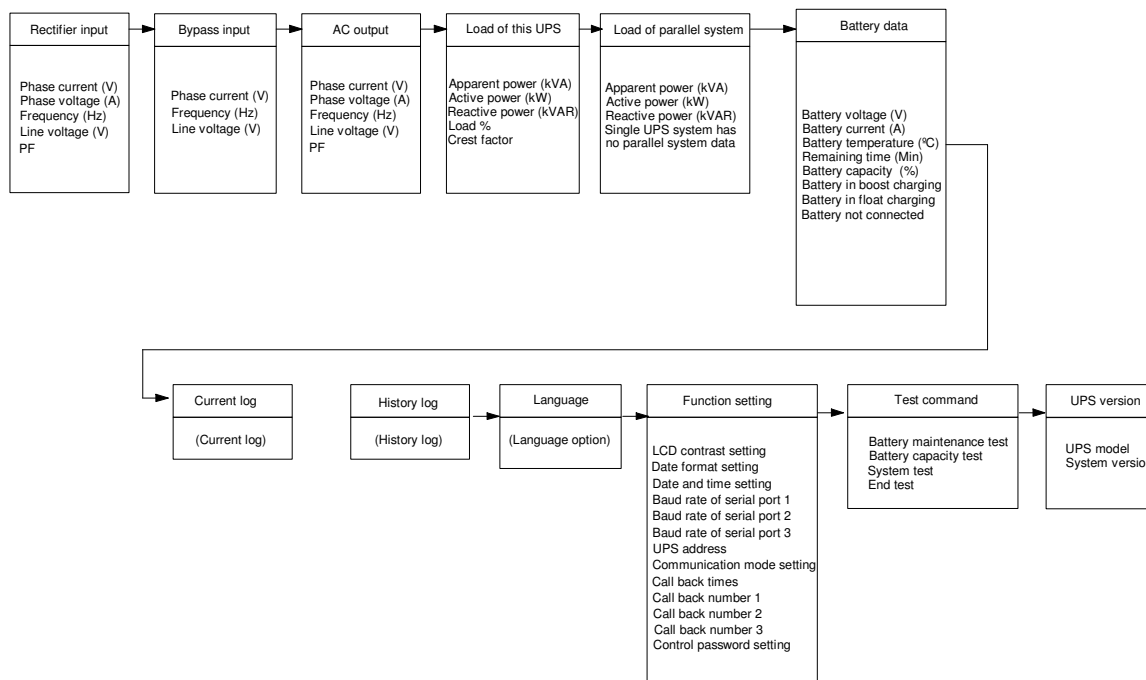

Fig. 7-3: Menu tree structure

7.1.5 Detailed Description Of Menu Items

The LCD menu tree shown in Fig. 7-2 is described in details below.

UPS information window: Display basic information of UPS, including current time, date, UPS name, configuration and status. This window displays the UPS basic information and is not necessary for the user to operate. The information of this window is given in the following table.

Display contents	Meanings
Liebert APM	UPS Name
10:07:55	Current Time (format: 24 hours, hour, minute, second)
1#	Unit 1
(Status) Normal, alarm and fault	Normal: UPS in normal condition Alarm: UPS has general alarm, such as AC input fault Fault: UPS fuse or hardware fault

Tab. 7-11: UPS information window Items description

UPS menu and data window

Use left key or right key to select UPS menu and data window.

Menu name	Menu item	Meanings
Main Input	Vphase (V)	The Phase Voltage
	Iphase (A)	The Phase Current
	Freq. (Hz)	The Frequency
	Vline (V)	The line-line Voltage
	PF	Power factor
Bypass Input	Vphase (V)	The Phase Voltage
	Freq. (Hz)	Bypass frequency
	Vline (V)	The line-line Voltage

Menu name	Menu item	Meanings
AC output	Vphase (V)	The Phase Voltage
	Iphase (A)	The Phase Current
	Freq. (Hz)	The output frequency
	Vline (V)	The line-line Voltage
	PF	Power Factor
This UPS module's load	Sout (kVA)	Sout: Apparent Power
	Pout (kW)	Pout: Active Power
	Qout (kVAR)	Qout: Reactive Power
	Load (%)	Load: The percent of the UPS rating load.
	CF	CF: Output Current Crest Factor
This parallel system's load	Sout (kVA)	Sout: Apparent Power
	Pout (kW)	Pout: Active Power
	Qout (kVAR)	Qout: Reactive Power
	Single Unit, No Parallel System Data	When UPS is configured as a single unit, there is only module load, no system load
Battery data	Battery Voltage (V)	Battery bus voltage
	Battery Current (A)	Battery bus current
	Battery Temp. (□)	Internal battery temperature
	Remaining Time (Min.)	Remaining battery backup time
	Batt. Boost Charging	Battery is boost charging
	Batt. Float Charging	Battery is float charging
	Battery Disconnected	Battery is not connected
Current Record	(Current Record)	Display all current records
History Record	(History Record)	Display all history records
Language	(Language option)	2 languages can be selected
Settings	Display Contrast	Adjust LCD Display Contrast
	Date Format Set	YYYY MM DD, DD MM YYYY and MM DD YYYY formats can be selected
	Date & Time	Date/Time Set
	Comm1 baud rate	Communication baud rate setting of Intellislot 1
	Comm2 baud rate	Communication baud rate setting of Intellislot 2
	Comm3 baud rate	Communication baud rate setting of Intellislot 3
	UPS address	This setting is applicable to RS485 communication mode.
	Communication Mode	Communication Mode
	Callback Times	Reserved
	Phone No.1	Reserved
	Phone No.2	Reserved
	Phone No.3	Reserved
	Command Password	User can modify the command password
Test Command (Battery Test Control / System Test Control / Forced boost charging)	Battery Maintenance Test	This test will lead to the battery being partly discharged to activate battery, at the same time, the approximate battery capacity will be obtained. The load must be between 20% and 80%
	Battery Capacity Test	This test will lead to the battery being partly discharged to activate battery, at the same time, the accurate battery capacity will be obtained. The load must be between 20% and 80%
	System Test	This is the self test of UPS. The user activates this function, after 5 seconds, a pop-up window will appear to show the customer the result of this diagnosis
	Stop Testing	Manually Stop the test including maintenance test, capacity test and system test
	Forced boost charging	Manually start the boost charging
	Stop forced boost charging	Manually stop the boost charging
Version	UPS version	The version of inverter, rectifier and monitoring software
	UPS model	Provide UPS model information, for example: 400V~60Hz

Tab. 7-12: UPS menu and data window Item description

Current record window

This window records the current event that leads to the current operating mode of UPS, but does not record the short status that has been ceased.

Use F1, Up key and Down key to scroll through the events.

Refer to History Record window for the menu and data window for a complete history record.

7.2 UPS Event And Alarm List

The follow table gives the complete list of all the UPS events displayed by history record window and current record window, which have been described in 6.1.5 Detailed Description Of Menu Items.

UPS event	Meanings
Comm. Fail	The communication between internal monitor and power module or bypass module
Parallel Comm. Fail	The CAN bus communication between different UPS's within a parallel system fails. 1. Check if some UPS module in the parallel system has not been powered on, if so, power on the UPS module and check if the alarm ceases. 2. Press FAULT CLEAR key
Battery Overtemp.	The Battery temperature is over limit. Check battery temperature and ventilation
Ambient Overtemp.	The Ambient temperature is over limit. Check UPS room ventilation
Battery Life End	Battery is aged. (Reserved)
Battery Replaced	Battery should be replaced due to failure in battery test
Battery Low Pre-warning	Before the end of discharging, battery under-voltage pre-warning should occur. After this pre-warning, battery should have the capacity for 3 minutes discharging with full load. The time is user configured from 3 to 60 minutes. Please shut down the load in time
Battery End of Discharge	Inverter turned off due to low battery voltage. Check the mains power failure status and recover the mains power in time
Mains Volt. Abnormal	Mains Voltage exceeds the upper or lower limit and results in rectifier shutdown. Check the input phase voltage of rectifier
Mains Undervoltage	Mains Voltage is undervoltage with derated load. Check the input line-to-line voltage of rectifier
Mains Freq. Abnormal	Mains frequency is out of limit range and results in rectifier shutdown. Check the input voltage and frequency of rectifier
Rectifier fault	The rectifier has fault and results in rectifier shutdown and battery discharging
Rectifier Overtemp.	The temperature of the heatsink is too high to keep the rectifier running. The UPS can recover from this fault automatically. Check the environment and ventilation
Batt. Charger Fail	Battery charger over voltage
Control Power 1 Fail	Control Power 1 fails or is lost while UPS is operating
Mains Phase Reversed	Input phase sequence is reversed
Rectifier Over Current	Rectifier Over Current
Soft Start Fail	Rectifier could not start due to low DC bus voltage
Bypass Unable to Trace	This alarm is triggered by an inverter software routine when the amplitude or frequency of bypass voltage is beyond the normal range. The amplitude is $\pm 10\%$ of rated value. The alarm will automatically reset if the bypass voltage becomes normal. 1. First check and confirm if the bypass voltage and frequency displayed on the LCD are within the setting range. Note that the rated voltage and frequency are respectively specified by "Output Voltage" and "Output Frequency". 2. If the displayed voltage is abnormal, measure the actual bypass voltage and frequency. If the measurement is abnormal, check the external power supply
Bypass Abnormal	This alarm is triggered by an inverter software routine when the amplitude or frequency of bypass voltage exceeds the limit. The amplitude is $\pm 10\%$ of rated value. The alarm will automatically reset if the bypass voltage becomes normal. First check if relevant alarm exists, such as "bypass circuit breaker open", "reverse bypass phase rotation" and "input neutral line fault". If there is any relevant alarm, first clear this alarm. 1. Then check and confirm if the bypass voltage and frequency displayed on the LCD are within the setting range. Note that the rated voltage and frequency are respectively specified by "Output Voltage" and "Output Frequency". 2. If the displayed voltage is abnormal, measure the actual bypass voltage and frequency. If the measurement is abnormal, check the external bypass power supply. If the alarm occurs frequently, use the configuration software to increase the bypass high limit set point according to the user's suggestions
Inverter Asynchronous	This alarm is triggered by an inverter software routine when the inverter and bypass waveforms are misaligned by more than 6 degrees of phase angle. The amplitude is $\pm 10\%$ of rated value. The alarm

UPS event	Meanings
	will automatically reset if the alarm condition ceases. 1. First check if "Bypass Unable to Trace" or "Bypass Abnormal" alarm exists.If the alarm exists, first clear the alarm. 2. Check if the bypass voltage waveform is normal. If the bypass voltage waveform has severe distortion, please ask the user to confirm this and find a solution
Inverter fail	The inverter output voltage is abnormal and the load transfers to bypass
Inverter Overtemp.	The temperature of the inverter heat sink is too high to keep inverter running.This alarm is triggered by the signal from the temperature monitoring device mounted on the inverter heatsink.The UPS recovers automatically after the over temperature signal disappears and after 5 minutes delay. If over temperature exists, check: 1. Whether the ambient temperature is too high. 2. Whether the ventilation channel is blocked. 3. Whether fan fault happens 4. Whether inverter overload time is out
Fan fault	At least one of the cooling fans fails
Inverter Relay Fail	At least one of the static switches on the inverter side is open or short circuit.This fault is locked until power off
Bypass STS Fail	At least one of the static switches on the bypass side is open or short circuit.This fault is locked until power off
Operation Invalid	This alarm is triggered when an invalid operation occurs
Output Fuse Fail	At least one of the output fuses is blown.The inverter shuts down and the load transfers to bypass
Unit Over load	This alarm appears when the load rises above 105% of nominal rating.The alarm automatically resets once the overload condition is removed. 1. Check which phase has overload through the load (%) displayed in LCD so as to confirm if this alarm is true. 2. If this alarm is true, measure the actual output current to confirm if the displayed value is correct. Disconnect non-critical load.In parallel system, this alarm will be triggered if the load is severely imbalanced
System Over load	This alarm appears when the total load rises above 105% of the nominal rating of the UPSs.The alarm automatically resets once the overload condition is removed. Check which phase has overload through the load (%) displayed in LCD so as to confirm if this alarm is true. If this alarm is true, measure the actual output current to confirm if the displayed value is correct. Disconnect non-critical load.In parallel system, this alarm will be triggered if the load is severely imbalanced
Unit Over load Timeout	The UPS overload status continues and the overload times out. Note: 1. The highest loaded phase will indicate overload timing-out first. 2. When the timer is active, then the alarm "unit over load" should also be active as the load is above nominal. 3. When the time has expired, the inverter Static Switch is opened and the load transferred to bypass. The inverter shuts down and will restart after 10 seconds. 4. If the load decreases to lower than 95%, after 5 minutes, the system will transfer back to inverter mode.Check the load (%) displayed in LCD so as to confirm if this alarm is true.If LCD displays that overload happens, then check the actual load and confirm if the UPS has over load before alarm happens
Byp. Abnormal Shutdown	The voltage of both the bypass and inverter is abnormal.The load power is interrupted
Inverter Over Current	The inverter has over currents
Bypass Phase Reversed	Bypass Phase Rotation is Reversed.Under normal condition, Phase B lags behind phase A by 120 degree and phase C lags behind phase B by 120 degrees. Check if the bypass input phase rotation is correct.Correct the wrong phase rotation
Load Impact Transfer	The system transfers to bypass as a result of load impact. The UPS can recover automatically.Start the load according to sequences to reduce the load impact to inverter
Transfer Time-out	The load is on bypass because the output overload transfer and re-transfer is fixed to the set times during the current hour.The system can recover automatically and will transfer back to the inverter with 1 hour
Load Sharing Fault	UPSs working within a parallel system are not sharing the load current correctly
DC Bus Abnormal	Shut down inverter due to abnormal DC bus voltage.The load transfers to bypass
System Transfer	The whole paralleled UPS system transfer to bypass at the same time when one of them needs to transfer to bypass. This message will appear on the UPS with passive transfer to bypass
DC Bus Over Voltage	Rectifier, inverter and battery converter were shutdown because DC bus voltage is too high.Check if

UPS event	Meanings
	the rectifier has any fault.If no, check if overload has happened.Restart the inverter after the fault is cleared
Bypass Over Current	Bypass current is above 135% of the rated current.The UPS alarms but has no action
LBS Active	The LBS setting is active.It means the UPS is acting as an LBS master or slave in a dual bus configuration
Mains Neutral Lost	The mains neutral wire is lost or not detected
Protocol version clash	Protocol version between monitor unit and DSP unit is not compatible
Battery ground fault	Battery ground fault from dry contact signal
Manual Turn On	Turn on the inverter manually by pressing the button on the front panel
Manual Turn Off	Turn off the inverter manually by pressing the button on the front panel
EPO	Press EPO button on the front panel or receive the external EPO command
Interrupted Transfer Confirm	User press ENT key to cut the power the load and transfer the load to bypass according to the prompt information
Transfer Cancel	User press CANCEL key to cut the power the load and transfer the load to bypass according to the prompt information
Unit Risk Off Confirm	User press ENT key to shut down the UPS module in parallel system according to the prompt information
Parallel System Risk Off Confirm	User press ENT key to shut down the parallel system according to the prompt information
Fault Reset	Press the FAULT CLEAR (Fault Reset) button on the LCD panel
Alarm Silence	Press SILENCE ON/OFF (alarm silence) key on the panel
Turn On Fail	Fail to turn on the inverter manually.The reason may be the operation is invalid (the maintenance bypass circuit breaker is closed) or the DC bus or rectifier is not ready
Audible Alarm Reset	Press FAULT CLEAR or SILENCE ON/OFF button on the LCD panel
Bypass Mode	UPS in Bypass Mode
Normal Mode	UPS in Normal Mode
Battery Mode	UPS in Battery Mode
Source share mode	Inverter is supplied by battery and rectifier at the same time
UPS Shutdown	UPS Shutdown, output power-down
Generator Connected	Generator is connected and a signal is sent to UPS.You can start the source share mode according to UPS setting
BCB Open	BCB status (opened)
BCB Close	BCB status (closed)
Batt. Float Charging	Battery Status (Float Charging)
Batt. Boost Charging	Battery Status (Boost Charging)
Battery Discharging	Battery Status (Battery is discharging)
Battery Period Testing	Battery is in periodic self-testing (20% capacity discharging)
Batt. Capacity Testing	Battery is in capacity self-testing (100% capacity discharging)
Battery Maintenance Testing	Battery is in capacity self-testing (20% capacity discharging)
UPS System Testing	UPS System is self testing
Inverter in Setting	Inverter starts up and is in synchronization
Rectifier in Setting	Rectifier starts up and is in synchronization
Fan fault in maintenance bypass cabinet	Fan fault in maintenance bypass cabinet
External input isolating transformer over temperature	External input isolating transformer over temperature
External output isolating transformer over temperature	External output isolating transformer over temperature
Battery room environment abnormal	Check the battery room environment
Battery Reverse	Reconnect battery and check battery wiring
Battery Unavailable	Check battery and battery connections
AutoTurn On	UPS shutdown due to battery discharging, and inverter starts up automatically when mains power recovers
Rectifier Online Upgrading	Upgrade the rectifier software online

UPS event	Meanings
Inverter Online Upgrading	Upgrade the inverter software online
Monitor Online Upgrading	Upgrade the monitoring software online
LBS abnormal	LBS abnormal
DSP software fault	The inverter software and rectifier software does not belong one same model of UPS

Tab. 7-13: UPS event log

7.3 Prompt Window

When the system is operating, it will pop up a prompt window when the system warns the user of some event or asks the user to confirm some operation.

Prompt Window	Meanings
Transfer with interrupt, please confirm or cancel	Inverter and Bypass supplies are not synchronized and any load transfer between the supplies will cause a brief load interruption
The load is too high to be transferred with interrupt	The total load must be less than the capacity of one unit to allow a parallel system to perform an interrupted transfer from bypass to inverter
This Operation Leads to Output Shutdown, Confirm or Cancel	No alternative supply is available and any Inverter Off operation will cause the load to be de-energised.Wait for User to Confirm or Cancel
This operation leads to inverter overload, confirm or cancel	Turning off this inverter will lead to the overload of remaining inverter(s) in a parallel system.Wait for User to Confirm or Cancel
Turn on more UPS to carry current load	The number of paralleled inverters already turned on is insufficient to carry the existing load.User needs to turn on more UPS modules
Battery will be depleted, confirm	Battery Capacity test discharges the battery 100% and UPS will shut down.The system will prompt to ask the User to confirm.Cancel to end the battery discharging, and return to Normal mode
System self test finished - everything is ok.	No action required
System self test finished - Please check the current warnings.	Check "Current Records" window
Enter control password	Required for Battery or UPS test (default: 12345)
Battery Self Test aborted, condition not met	Battery self-test condition is not enough.User should check whether battery is in boost charging state and whether load level is greater than 20 percent
Battery Refresh Charge aborted, condition not met	When the user performs forced boost charging, but the boost charging condition is not satisfied, such as no battery, charger has failed, etc., the system prompts this message

Tab. 7-14: Prompt window and meanings

7.4 Default Screen

This default screen is displayed following at least 2 minutes of operation with no new alarm. After another delay, the backlight turns off. Press any key (F1~F5) to reactivate the screen.

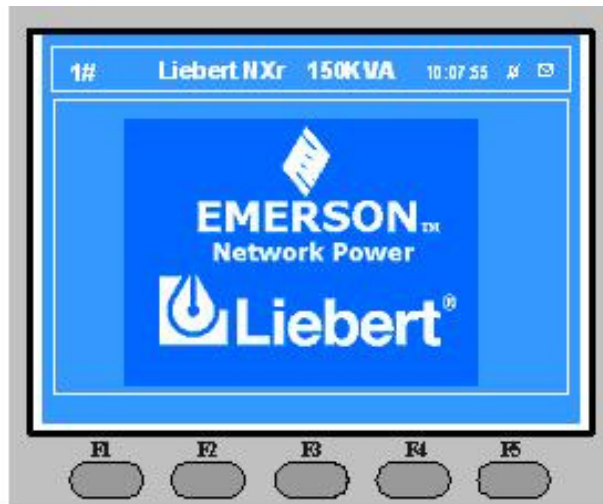

Fig. 7-4: Default screen

Chapter 8 Optional Parts

This chapter introduces the optional parts of LIEBERT APM UPS. The optional parts should be installed before the UPS installation.

8.1 Battery Ground Fault Detection Set

In addition to any residual current device mounted externally and upstream the UPS or when optional isolation transformers are fitted to the UPS, an optional residual battery current device can be fitted to detect leakage current so as to ensure the normal operation of the system. Residual current range monitored: 30mA ~ 3000mA

Power supply: 230Vac (L-N)

When a battery ground fault is detected, an alarm will appear on the UPS display panel.

An additional Dry contact fault Alarm signal is available for remote monitoring:

Terminal	Name	Definition
21	Common	Battery Ground Fault Detection – can be programmed as Alarm or Pre-Alarm
22	NC	
24	NO	

Tab. 8-1: Dry contact fault alarm signal is available for remote monitoring

The Battery ground fault detection set contains one CT (current transformer) and one DC sensitive residual current monitor. The connection of this set for UPS is illustrated as follows:

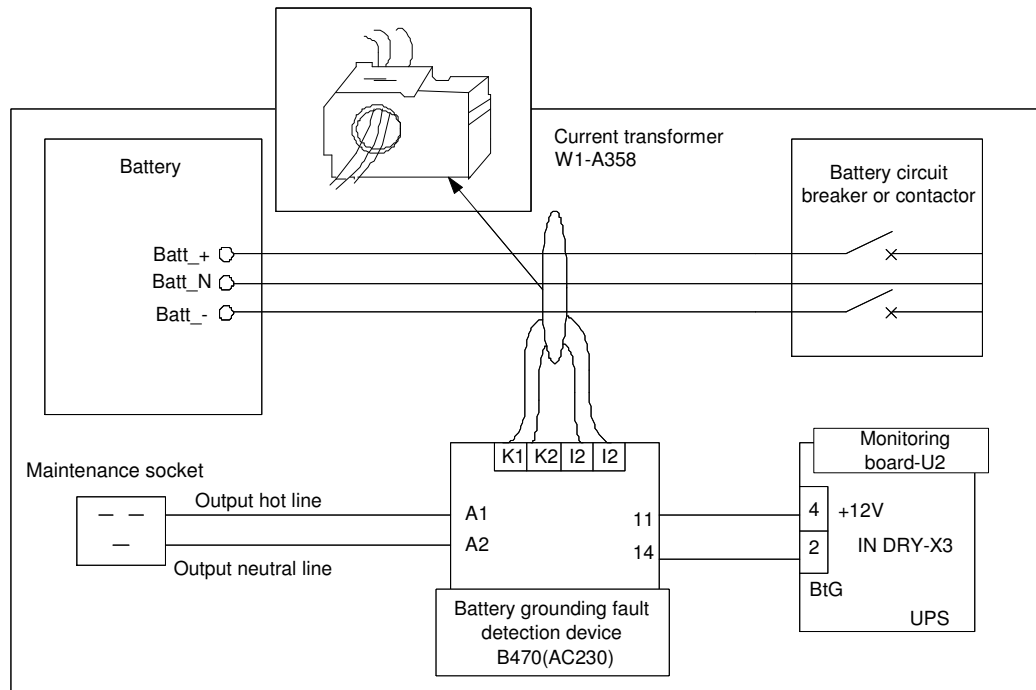

Fig. 8-1: Wiring of battery ground fault detection set

8.2 Replacing Dust Filters

Installing the two dust filters in the LIEBERT APM UPS requires only a Phillips screwdriver. Each filter is held in place by a bracket on either side of each filter. To replace each filter:

1. Open the UPS front door and locate the filters on the back side of the front door (see Fig. 8-2).
2. Remove one bracket and loosen the screw on the second bracket. The second bracket need not be removed.
3. Remove the dust filter to be replaced.
4. Insert the clean filter.
5. Reinstall the bracket, tightening the screw securely.
6. Tighten the screw on the second bracket.

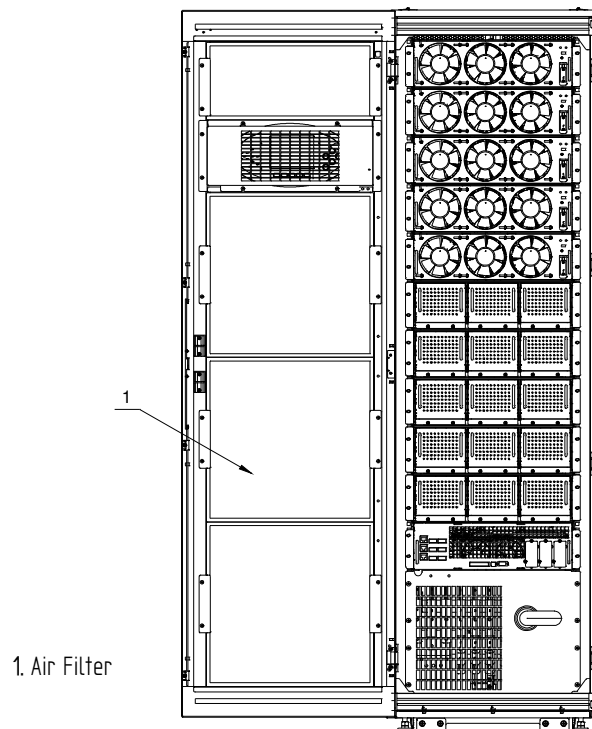

Fig. 8-2: Replacing Air Filters

Chapter 9 Product Specifications

9.1 CONFORMITY AND STANDARDS

The UPS has been designed to conform to the following European and international standards:

Standards and Directives:

Item	Normative reference
Low Voltage Directive	2006/95/EC with the Amendment Directive 93/68/EEC Directive for electromagnetic compatibility 2004/108/EC
General and safety requirements for UPS used in operator access areas	IEC/EN 62040-1-1 incorporating requirements of IEC/EN 60950-1
Electromagnetic compatibility (EMC) requirements for UPS	IEC/EN 62040-2: Immunity category C2, Emission category C2
Method of specifying the performance and test requirements of UPS	IEC/EN/AS 62040-3

Tab. 9-1: Compliance with European, international standards

The above mentioned product standards incorporate relevant compliance clauses with generic IEC and EN standards for safety (IEC/EN/AS60950), electromagnetic emission and immunity (IEC/EN/ AS61000 series) and construction (IEC/EN/AS60146 series and 60529).

Item	Unit	30kW	90kW	150kW
Acoustic noise level at 1 meter full load	dB	<53dBA	<58dBA	<62dBA
Acoustic noise level at 1 meter half load	dB	<52dBA	<56dBA	<58dBA
Altitude of Operation	m	≤1000m above sea level, derate power by 1% per 100m between 1000m and 2000m		
Relative Humidity	-	0 to 95% non condensing		
Operating Temperature	°C	0 to 40 °C *; Note: Battery life is halved for every 10 °C increase above 20 °C		
UPS Storage-Transport Temperature	°C	-20~70		
Recommended Battery Storage Temperature	°C	-20 °C to 30 °C (20 °C for optimum battery storage)		

Tab. 9-2: Environmental parameters

- Conditions apply

AC/AC Efficiency	Unit	Data				
Rated Power	kVA	30~150				
Normal mode ¹ (dual conversion)	%	96				
Battery Mode ²	%	96				
Heat Losses & Air Exchange						
Rated Power	kVA	30	60	90	120	150
Normal Mode	kW	1.2	2.4	3.6	4.8	6
No Load	kW	0.6	1.2	1.8	2.4	3
Maximum forced air cooling (front intake, rear exhaust)	L/sec	48	96	144	192	239

Tab. 9-3: AC/AC Efficiency, Loss and Air Exchange

1) 400Vac input and output, battery fully charged, full-rated linear load.

2) Inverter Efficiency (DC/AC), battery at nominal voltage 432VDC and full-rated linear load

Dimensions, W×D×H	mm	600×1100×1996				
Number of Modules	kVA	1	2	3	4	5
Weight, without battery modules	kg	280	315	350	385	420
Power Module dimensions	mm	440×132(3U)×650				
Power Module weight	kg	35				
Battery Module dimensions	mm	440×132(3U)×877				
Battery Module weight	kg	95				
Battery Box dimensions	mm	14×132(3U)×810				
Battery Box weight	kg	29				
Color	N/A	ZP7021				
Protection Degree IEC (60529)	N/A	IP20 (finger-proof with front doors open or closed)				

Tab. 9-4: UPS mechanical characteristics

Rated Power, kVA	Unit	30kW	60kW	90kW	120kW	150kW
Rated AC Input Voltage ¹	Vac	380/400/415 V(three-phase and sharing neutral with the bypass input)				
Input voltage range ²	Vac	305V~477V, 304V~208V (output derating lower than 70%)				
Frequency ²	Hz	50/60Hz (range: 40Hz to 70Hz)				
Power Factor	kW/kVA, full load (half load)	0.99 (0.98)				
Input power	kVA rated ³ (maximum ⁴)	34	68	102	136	173
Input current	Amps rated ⁵ (maximum ⁴)	54	108	162	216	270
THD	THDI %	< 3				

Tab. 9-5: Rectifier AC input (Utility)

1. Rectifier operates at any of the rated supply voltages and frequencies without further adjustment.
2. At 305V input mains, the UPS maintains the specified output voltage at rated load without discharging a previously charged battery.
3. EN 62040-3 / 50091-3: at rated load and input voltage 400V, battery charged
4. EN 62040-3 / 50091-3: at rated load and input voltage 400V, battery charging at maximum rated power.

Intermediate DC circuit		30~150				
Rated Power, kVA	Unit	30~150				
Battery bus voltage	Vdc	Nominal: 432V (VRLA Float charge is 540V) 36 jars of 12V VRLA Range: 400V ~ 616V				
Quantity of lead-acid cells	Nominal	216=[36x6cell (12V)blocks]				
	Maximum	240=[40x6cell (12V)blocks]				
	Minimum	180=[30x6cell (12V)blocks]				
Float Voltage	V/cell (VRLA)	2.25 V/cell (selectable from 2.2 –2.3V/cell), Constant current and constant voltage charge mode				
Temperature compensation	mV/C°	- 3.0 (selectable 0 to – 5.0 around 25°C or 30°C or inhibit)				
Ripple Voltage	% V float	≤1				
Ripple Current	~ C ₁₀	≤5				
Boost charge Voltage	VRLA	2.35 V/cell (selectable from 2.30-2.40V/cell) Constant current and constant voltage charge mode				
Boost Control	-	- float-boost current trigger 0.050 C ₁₀ (selectable 0.030-0.070) - boost-float current trigger 0.010 C ₁₀ (selectable 0.005-0.025) 24 hr safety time-out (selectable 8-30 hr) boost charge mode inhibit also selectable				
End Of Discharge	V/cell (VRLA)	1.63 V/cell (selectable from 1.60-1.750V/cell) Auto Inverse EOD voltage x discharge current mode (The end of discharge voltage increases at low discharge currents)				
Battery Charge	V/cell	2.4 V/cell (selectable from 2.3-2.4V/cell) Constant current and constant voltage charge mode Programmable auto trigger or inhibit of boost mode				
Battery Charging	# of Modules	1	2	3	4	5

Power ¹ Max Current (Adjustable) ²	Battery Charging Power (kW)	4.5	9	13.5	18	22.5
	Max Charging Current A	11	22	33	44	55

Tab. 9-6: Intermediate DC circuit

1. At low input voltage the UPS recharge capability increases with load decrease (up to the maximum capacity indicated).

2. Maximum currents listed are for end of discharge voltage of 1.67 V/cell for 240 cells.

Rated Power, kVA	kVA	30~150
Rated Power, kW	kW	30~150 (Same kW as that of kVA)
Rated AC Voltage ¹	Vac	380/400/415 V (three-phase four-wire and sharing neutral with the bypass input)
Frequency ²	Hz	50/60
Overload capacity	%	<105% load, 60min 105%~125% load, 10min 125%~150% load, 1min >150% load, 200ms
Fault Current	%	200A RMS Ampere short current limitation for 200 msec, then inverter is turned off
Non linear load capability ³	%	100%
Neutral current capability	%	170%
Steady state voltage stability	%	± 1 (balanced load)
Transient voltage response ⁴	%	±5
THD	%	< 1 (linear load), <4.0 (non linear load ⁵)
Synchronisation - Window		Rated frequency ± 2 Hz (selectable ± 0.5 to ± 3Hz)
Max change rate of synch frequency	Hz/ s	0.2Hz/sec

Tab. 9-7: Inverter output to critical load

1. Factory set to 400V – 380 or 415V selectable by commissioning engineer.

2. Factory set to 50Hz; 60 Hz selectable by commissioning engineer. Frequency converter operation also selectable.

3. EN50091-3 (1.4.58) crest factor: 3:1

4. IEC62040-3/ EN 50091-3 also for 0-100-0% load transient. Transient recovery time: return to within 5% of steady state output voltage within half a cycle.

Rated Power, kVA	Unit	30~150	
Rated AC Voltage ¹	Vac	380/400/415V three-phase four-wire, sharing neutral with the rectifier input and providing neutral reference to the output	
Rated current	380V	A	225
	400V	A	215
	415V	A	205
Overload	%	135% load, long term at 40° ambient temperature	
$i^2 t$	A ² S	405000 @25°; 320000@130°	
Suggested Upstream protection, bypass line	N/A	Thermomagnetic circuit-breaker, rated up to 125% of nominal output current. IEC 60947-2 curve C.	
Current rating of neutral cable	A	1.7×In	
Frequency ²	Hz	50/60	
Transfer time (between Bypass and Inverter)	ms	Synchronous transfer: (< 2ms Asynchronous transfer (default): 15 ms (50 Hz), 13.3 ms (60 Hz) or 40, 60, 80, 100 ms selectable	
Bypass voltage tolerance	%Vac	Upper limit: +10, +15 or +20, default +15 Lower limit -10, -20, -30 or -40, default: -20 (delay time to accept steady bypass voltage: 10 sec)	
Bypass frequency	%	±10 or ±20, default ±10	

tolerance		
Synchronisation - Window	Hz	Rated frequency ± 2 Hz (selectable ± 0.5 to ± 3 Hz)

Tab. 9-8: Bypass input

1. Factory set to 400V, 380 or 415V selectable by commissioning engineer.
2. Factory set to 50Hz; 60 Hz selectable by commissioning engineer.

If the UPS is set to frequency converter mode, the bypass status will be neglected.

Appendix 1 Information for the protection of the Environment

This unit makes use of components dangerous for the environment (electronic cards, electronic components and batteries). The components removed must be taken to specialized collection and disposal centers. In case of complete unit dismantling, this operation shall be carried out by specialized personnel and the unit must be taken to centers specialized in collection and disposal of dangerous substances.

Part name	Hazardous Substances or Elements Announcement					
	Lead	Mercury	Cadmium	Chrome	PBB	PBDE
	Pb	Hg	Cd	Cr ⁶⁺	PBB	PBDE
Hex copper stud	x	o	o	o	o	o
PCBA	x	o	o	o	o	o
AC capacitor	x	o	o	o	o	o
DC capacitor	x	o	o	o	o	o
Fan	x	o	o	o	o	o
Cables	x	o	o	o	o	o
LCD	x	x	o	o	o	o
Sensors	x	o	o	o	o	o
Large-medium power magnetic components	x	o	o	o	o	o
circuit breaker / rotating switch	x	o	o	o	o	o
Semiconductors	x	o	o	o	o	o
Battery (when applicable)	x	o	o	o	o	o
Insulation monitoring device (when applicable)	x	o	o	o	o	x
<p>o: Means the content of the hazardous substances in all the average quality materials of the part is within the limits specified in SJ/T-11363-2006</p> <p>x: Means the content of the hazardous substances in at least one of the average quality materials of the part is outside the limits specified in SJ/T11363-2006</p>						
<p>Emerson Network Power Co., Ltd. has been committed to the design and manufacturing of environment-friendly products. It will reduce and eventually eliminate the hazardous substances in the products through unremitting efforts in research. However, limited by the current technical level, the following parts still contain hazardous substances due to the lack of reliable substitute or mature solution:</p> <ol style="list-style-type: none"> 1. All solders in the products contain lead 2. Copper alloy contains lead 3. Backlight bulb contains Mercury 4. The ceramic materials of the ceramic capacitor, the copper terminals and copper leads of metallic film capacity contain lead. 5. The glass of resistor contains lead. 6. The glass of LCD contains lead, and the backlight lamp contains Mercury. 7. The lead in the battery is determined by the battery feature and technical levels. 8. The insulation monitoring device contains lead and PBDE. 						
<p>About Environment Protection Period: The Environment Protection Period of the product is marked on the product. Under normal working conditions and normal use of the products observing relevant safety precautions, the hazardous substances in the product will not seriously affect the environment, human safety or property in the Environment Protection Period starting from the manufacturing date.</p>						

About battery: The battery life is dependent on the ambient temperature and charging / discharging times. The battery life will be shortened if the battery is used under high temperature or in deep discharging status. Refer to product manual for details. If a battery has leakage or is damaged, it must be replaced, stored in a container resistant to sulfuric acid and disposed of in accordance with local regulations.

The waste lead-acid battery is a kind of hazardous waste and is one of the major contaminants controlled by government. Therefore, its storage, transportation, use and disposal must comply with the national or local regulations and laws about the disposal of hazardous waste and waste batteries or other standards.

According to the national laws, the waste lead-acid battery should be recycled and reused, and it is prohibited to dispose of the batteries in other ways except recycling. Throwing away the waste lead-acid batteries at will or other improper disposal methods will cause severe environment pollution, and the person who does this will bear the corresponding legal responsibilities.

As a lead-acid battery supplier, Emerson Network Power Co., Ltd. has set up a service network and a recycling system for waste batteries so as to help the customers to dispose of the waste batteries properly. Please obtain the recycling system of Emerson Network Power Co., Ltd. from the local Emerson office or nearest Emerson office. If the customer does not accept this requirement or does not use the waste batteries recycling system set up by Emerson Network Power Co., Ltd., Emerson Network Power Co., Ltd. will not bear any responsibility due to improper disposal of the waste batteries.

Applicable scope: LIEBERT APM 1UPS Series

Ensuring The High Availability Of Mission-Critical Data And Applications.

Emerson Network Power, the global leader in enabling business-critical continuity, ensures network resiliency and adaptability through a family of technologies – including Liebert power and cooling technologies – that protect and support business-critical systems. Liebert Solutions employ an adaptive architecture that responds to changes in criticality, density and capacity. Enterprises benefit from greater IT system availability operational flexibility and reduced capital equipment and operating costs

Technical Support / Service

Web Site

www.liebert.com

Monitoring

liebert.monitoring@emerson.com

800-222-5877

Outside North America:+00800 1155 4499

Single-Phase UPS & Server Cabinets

Liebert.upstech@emerson.com

800-222-5877

Outside North America:+00800 1155 4499

Three-Phase UPS & Power Systems

800-543-2378

Outside North America +1 614 -841-6598

Environmental Systems

800-543-2778

Outside the United States +1 614 -888-0246

Locations

United States

1050 Dearborn Drive

P.O. Box 29186

Columbus Ohio 43229

United States

Europe

Via Leonardo Da Vinci 16/18

Zona Industriale Tognana

35028 Piove Di Sacco (PD) Italy

Tel.: +39 049 9719111

Fax: +39 049 5841 257

Asia

29/F, The Orient Square Building

F.Ortigas Jr Road, Ortigas Center

Pasig City 1605

Philippines

Tel.: +63 2 687 6615

Fax: +63 2 730 9572

While every precaution has been taken to ensure the accuracy and completeness of this literature, Liebert Corporation assumes no responsibility and disclaims all liability for damages resulting from use of this information or for any error or omission.

©2010 Liebert Corporation

All right reserved throughout the world. Specifications subjected to change without notice

® Liebert is a registered mark of Liebert Corporation

All names referred to are trademarks

or registered trademarks of theirs respective owners

Ref.: SL-54321_REV_2.2_07-10

Emerson Network Power

The global Leader in enabling Business-Critical Continuity.

■ AC Power

■ Embedded Computing

■ Outside Plants

EmersonNetworkPower.com

■ Racks & Integrated Cabinets

■ Connectivity

■ Embedded Power

■ Power Switches & Controls

■ Services

■ DC Power

■ Monitoring

■ Precision Cooling

■ Surge Protection

Business Critical continuity, Emerson network power and Emerson Network Power Logo are trademarks and services marks of Emerson Electric Co.
©2010 Emerson Electric Co.